

BELT CONVEYOR CONTROL 308



The original instruction **Operation and Maintenance Manual**

1. Identification of the machine

Euro Prima operates a policy of ongoing development and therefore reserves the right to make changes and improvements to any products described in this document.

To support you as soon as possible Please enter the information here.

<i>Description:</i>	Control table CONTROL 308
---------------------	----------------------------------

<i>No:</i>	<i>Description:</i>	<i>Machine No:</i>	<i>Power:</i>	<i>Weight:</i>
1	CONTROL 308	44/16; 2016 (RN1133)	0,25 kW	250 kg

<i>Accessories:</i>	Magnet fi 32 Electronic regulation
---------------------	---------------------------------------

<i>Bayer:</i>	Fitoherb Kft. (Ltd) Teréz körút 40. I. em. 13. 1066 Budapest
---------------	---

<i>Manufacturers' address:</i>	Euro Prima d.o.o. Zorana Radmilovića bb; Veternik; Srbija Tel: +381 (0)21 302 442; +381 (0)21 302 443 www.europrima.rs; e-mail: eprima@EUnet.rs
--------------------------------	---



2. Table of contents

1. Identification of the machine.....	2
2. Table of contents.....	3
3. Preliminary information.....	4
3.1 Target group for this operating manual.....	4
3.2 For your safety.....	4
3.3 For the employer.....	4
3.4 Meaning of the symbols.....	4
4. Safety.....	5
4.1 For your safety.....	5
4.2 Warning symbols.....	5
5. Safety.....	7
5.1 Identification of the operator.....	7
5.2 Coupling.....	7
5.3 Operating the machine.....	7
5.4 Further regulations.....	9
5.5 Delivery size.....	9
6. Familiarization.....	10
6.1 Basic characteristics.....	10
6.2 Technical characteristics.....	11
6.3 Description of device.....	12
6.3.1 CONTROL 308.....	12
7. Instruction for installation, safety use and maintenance.....	14
7.1 Instructions for mounting.....	14
7.2 Instructions for safe operation.....	15
7.2.1 Regulation of the inclination angle of the belt.....	15
7.2.2 Regulation of belt centering	16
7.3 Instructions for maintenance.....	17
7.4 For your safety.....	17
7.5 List of spare parts.....	18
7.5.1 Spare parts for CONTROL 308 (RN1132/16).....	18
8. Eliminating malfunctions.....	19
9. Disposing of the machine.....	20

3. Preliminary information

3.1 Target group for this operating manual

This operating manual is directed at trained farmers and individuals who are otherwise qualified to perform agricultural activities and who have received training in the operation of this machinery.

3.2 For your safety

Before attempting to use or install this machinery, familiarise yourself with the contents of this operating manual. In this way, performance and work safety are optimised.



3.3 For the employer

All personnel are to be trained in the use of the machine regularly (at least once a year) in accordance with employers' liability insurance association guidelines. Untrained or unauthorised individuals are not permitted to use the machinery. Your dealer will instruct you in the operation and care of the machinery.

3.4 Meaning of the symbols

We have used various symbols to make this manual clear and easy to read. They are explained below.

We have also used pictograms to help you find instructions more quickly:

 <p>Note</p>	This symbol in the text points out to the instructions which will make your work easier, more efficient and safe.
 <p>Attention!</p>	This symbol in the text may point out to the possible machine damage, tools, etc., but also that certain financial or legal responsibility are acquired if instructions are not followed, for example losing of right on guarantee.
 <p>DANGER!</p>	This symbol in the text warns on the danger of injuries, even death of people or animals.

4. Safety

4.1 For your safety

In this chapter you will find general safety instructions. Each chapter of the operating manual contains additional specific safety instructions, which are not described here. Observe the safety instructions.

- in the interest of your own safety,
- in the interest of the safety of others, and
- to ensure the safety of the machine.

Numerous risks can result from handling agricultural machines in the wrong way. Therefore, always work with special care and never under pressure.

The employer should:



Inform personnel working with the machine of these safety instructions at regular intervals and according to statutory regulations.

Manufacturer is not responsible for any losses incurred due to violation of orders or regulations that are generally applicable, and violation of orders and guidelines given in this manual.

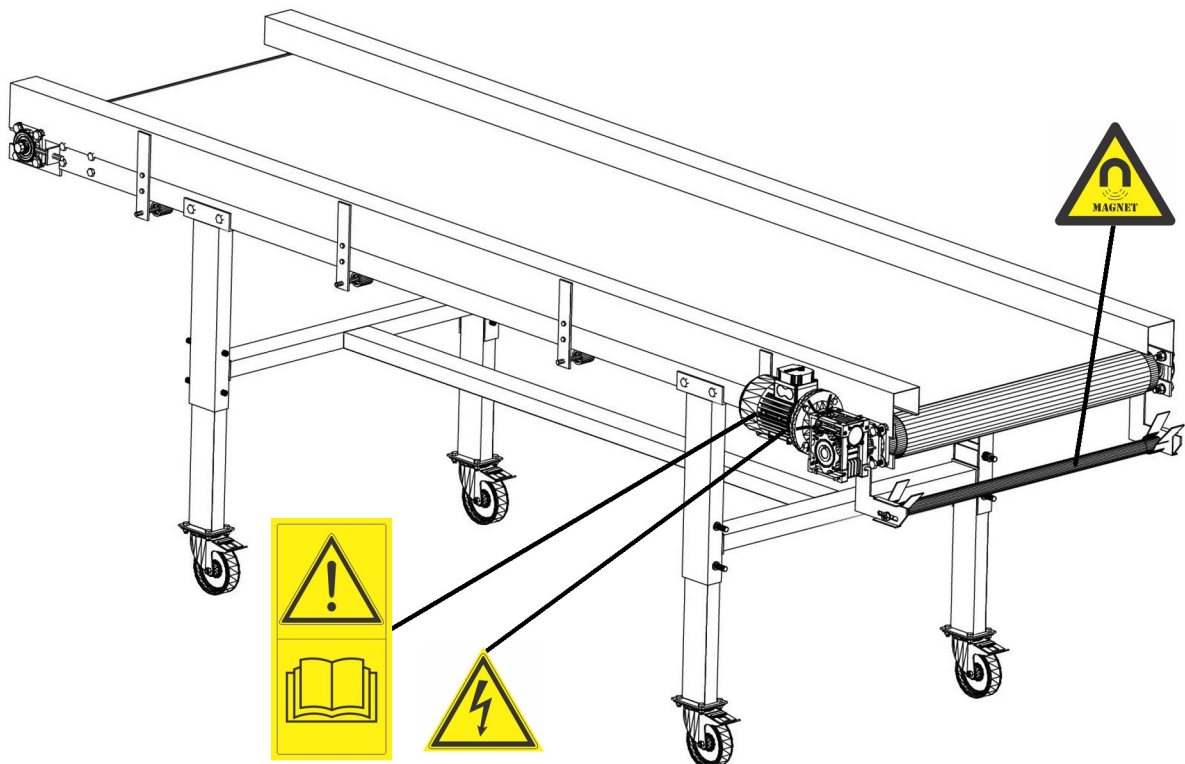
4.2 Warning symbols



Warning label meaning

	<p>Read and follow the instructions for safety operation and maintenance. You may use the machine only if instructions are studied carefully. It refers especially to the instructions related to the safe operation.</p>
	<p>Switch off the motor and disconnect the cube from the electric power before the operation, maintenance or repair.</p>
	<p>Do not stand under or near overlapping parts. It is very dangerous to stand underneath the overlapping areas. Caution. Danger of falling elements. Device or its parts may lean or fall. Before you enter a dangerous zone always put washers.</p>
	<p>Risk of electric shock Before accessing the voltage zone, switch off the power supply. Access is permitted only to an expert who is familiar with this instruction.</p>
	<p>Protective covers Hardest work is to be done without protective covers. Do not open and remove protective coverings while the engine is running.</p>

5. Safety

5.1 Identification of the operator

- **Who is authorised to operate the machine?**

Only qualified personnel

Only qualified persons who have been informed of the dangers associated with handling the machine are permitted to operate, service or repair the machine. As a rule, such persons are trained and experienced in agricultural work or have been thoroughly trained in a similar fashion.

5.2 Coupling

- **Connect electric wires or cables only after machine is installed.**

5.3 Operating the machine

- **Anchoring**

The machine should not be put into operation until the user has been trained to use it.

The machine must not be put into operation until the user is familiar with these instructions in details. Operation without training can lead to damage to the machine due to incorrect operation or to accidents.

- **Ensure that the machine is in perfect working condition.**

Do not operate the machine unless it is perfect working condition. Check all important components and replace any defective components before starting the machine. Defective components can cause damage to equipment and injury to persons.

- **Do not remove the protective equipment.**

Protective equipment must not be removed or by-passed. Check all protective equipment before starting the machine. Unprotected machine components can cause severe or fatal accidents.

During the herbs processing dust may be stirred up if it is contained in the herbs. The machine does not include any aspirator, so it is necessary that operators wear protection mask to prevent inhaling of the dust.

- **Make sure the immediate vicinity is clear**

Before starting, unfolding and commencing operation, check the surrounding area of the machine. Make sure the operator has a sufficient view of the work area. Do not begin work until the immediate vicinity is cleared of any persons or objects. Any use of the machine without verification of the situation around can lead to accidents.

- **Re tighten all nuts, bolts and screws**

Nuts, bolts and screws should be checked at regular intervals and tightened if necessary. Screws/bolts can come loose unnoticed while operating. Damage can occur to the unit or injury to persons.

- **What to do in the event of a malfunction**

In the event of a malfunction, shut down and secure the machine immediately. Turn off the electric power supply to the machine and safe the machine. The malfunction may be eliminated immediately, or a work shop must be assigned the task. Further operation of the machine can lead to damage to the machine or injury to persons.

- **Keep the children away from the machine**

Children have no sense of danger and they are not allowed to be close to the machine, either it is in operation or just stored.

- **Care and Maintenance**

Follow the care and maintenance chart

Observe prescribed intervals for maintenance checks and inspections specified in the operating manual. No observance of the time periods can lead to damage to the machine, poor quality of work or accidents.

- **Use only genuine spare parts**

Many components have specific characteristics that are essential for accurate functioning and stability of the machine. Only these parts and accessories supplied by the Manufacturer have been tested and approved. Using other products may cause defects or reduce the operational safety. Using non-genuine spare parts can violate the warranty, and the manufacturer is exempt from all liability.

- **When performing care and maintenance work:**

- Switch off the electric power source.
- Check if the machine is placed properly and safely. If necessary, make additional safety steps. (machine must not stand on the wheels)
- Do not use parts of the machine to climb onto it;
- Never reach into the V-belt while it is turning.

It is only possible to guarantee work safety during care or maintenance work through observing these regulations.

- **Turn off the electrical supply**

Prior to carrying out work on the electrical system, disconnect it from the power supply. Equipment under electrical power can cause damage to equipment and injury to persons.

- **Tighten all screwed/bolted connections**

All screwed/bolted connections that are released during maintenance and repair operations must be re tightened. Screws/bolts can loosen unnoticed during operation due to loose connections and therefore parts of the machine can come loose. Severe injury to persons or damage to equipment can result.

5.4 Further regulations

- **Observe the regulations**

In addition to those listed above, please observe the following safety instructions:

- Accident-prevention regulations.
- Generally recognised safety regulations, occupational health requirements and road traffic regulations.
- Information in this operating manual.
- Regulations pertaining to operation, maintenance and repair.

5.5 Delivery size

- The machine is delivered completely assembled.

- **Do not assemble the device yourself.**

Do not assemble the device yourself, because per-requests for a normal device status are:

- Process steps application,
- Safe handling of electronic equipment.



Note!

If parts are missing or are damaged during transportation, please immediately send a complaint to your dealer, importer or manufacturer.

6. Familiarization

This section contains general information on your machine as well as information on:

- Range of application,
- Features,
- Designation of the assemblies,
- Technical specifications, i
- Scope of delivery.

6.1 Basic characteristics

- Belt transporter as the most efficient way of horizontal transportation and slightly sloped transportation has a wide range of use both within industrial installations and individual farms. Here are some advantages that characterize belt transporter in comparison to other types of transporters: no damages of transporting material, noiseless operation, minimal thrust per meter of transporting material, low costs, long life.
- Belt transporters produced by Euro Prima have wide range of use, they provide safe operation and require minimum maintenance.
- Length of transporting belt varies within range 2m to 20 m, measured from the axis of the drive roller to the axis of tension roller; width of the transporting belt is 0,2 – to 1 m.
- Numerical mark on the belt transporter designation determines the length of the transporter and the width of the transporting belt according to the following principle:
 EP 202 Vario – first figure (No.2), designates the length of the transporter from the axis of the drive roller to the axis of the tension roller (up to 2 m). Next two figures (02) designate width of the transporting belt in meters. Mark Vario refers to the transporter which has variable (changable) angle and height of lifting. Belt transporter which does not contain mark »Vario« is a flat transporter. This device does not make noise during the operation and does not transfer vibrations around.
- General view of the belt transporter with dimensions is shown on the Fig.

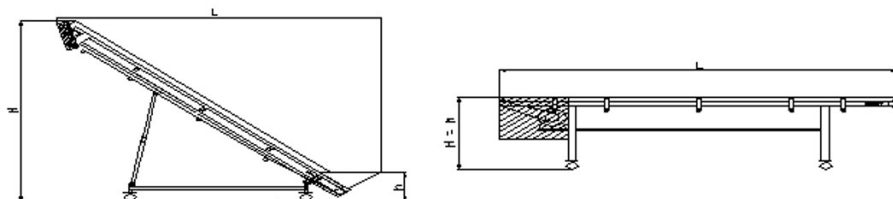

6.2 Technical characteristics

- All drums are of barrel shape in order to provide band guidance.
- With and length of abutment frame, i.e. wheel distance, is adjusted to enable full side and length stability of the belt transporter, whether it stands on a firm or wheel support. In principle width of abutment is always double width of the supporting frame of the belt if lifting height is 2 m, triple width of the supporting frame of the belt if lifting height is 4 m, and for higher lifting it is four widths or more.

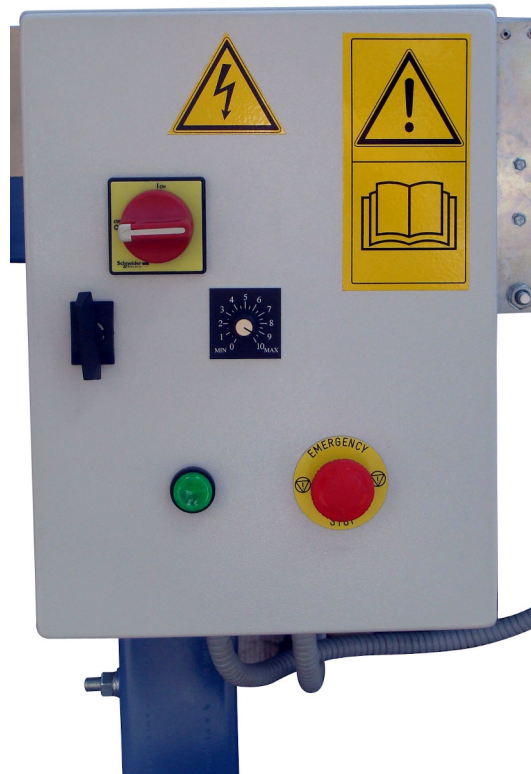



Figure: Control table of CONTROL 308

 <p>DANGER!</p>	<p>Protecting fence is mounted. Customer shall inform producer thereon, so that work out of protecting fence could be planned. If transporting belt is made without fence, load may fall down and cause injuries!</p>
---	---

6.3 Description of device

6.3.1 CONTROL 308

Layout of the machine is shown on figure.

Belt transporter CONTROL 308 consists of the following assemblies:

- | | |
|--------------------------------|--|
| (1) - Upper support structure; | (10) - Electric motor reductor; |
| (2) - Rolling bearings; | (11) - Side fence; |
| (3) - Drive drum; | (12) - Supporting rollers; |
| (4) - Tension drum; | (13) - Side carrier; |
| (5) - Relay mechanism; | (14) - Cleaner driven drum; |
| (6) - Belt conveyor; | (15) - Cleaner belt; |
| (7) - Lower support structure; | (16) - Carrier of magnet and magnet; |
| (8) - Telescopic legs; | (17) - Concettrator for goods on exit; |
| (9) - Wheels; | (18) - Box. |

<i>Length of transporting belt, m</i>	3
<i>Width of transporting belt B, m</i>	0.8
<i>Speed of transporting belt, m/s</i>	0,15 – 2,5 m/s
<i>Diameter of drive roller and tension roller</i>	108 mm
<i>Type of belt transporter, Control /</i>	CONTROL 308
<i>Output of electric motor, driving electric motor-reducer, kW/voltage, V/no. r.p. min⁻¹</i>	0.25 KW/230V/50Hz
<i>Overall dimensions, length L, height (H_{max}/H_{min})</i>	3.126 m x 0,75 m x 0,85m

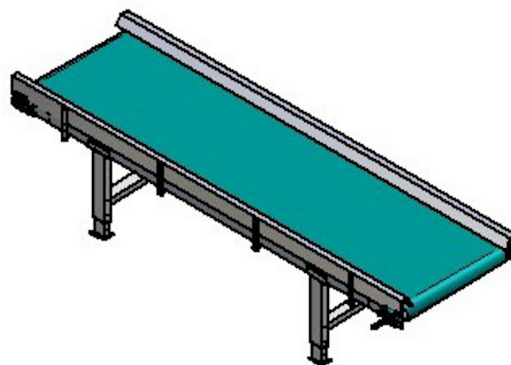

Figure: Belt conveyor CONTROL 308

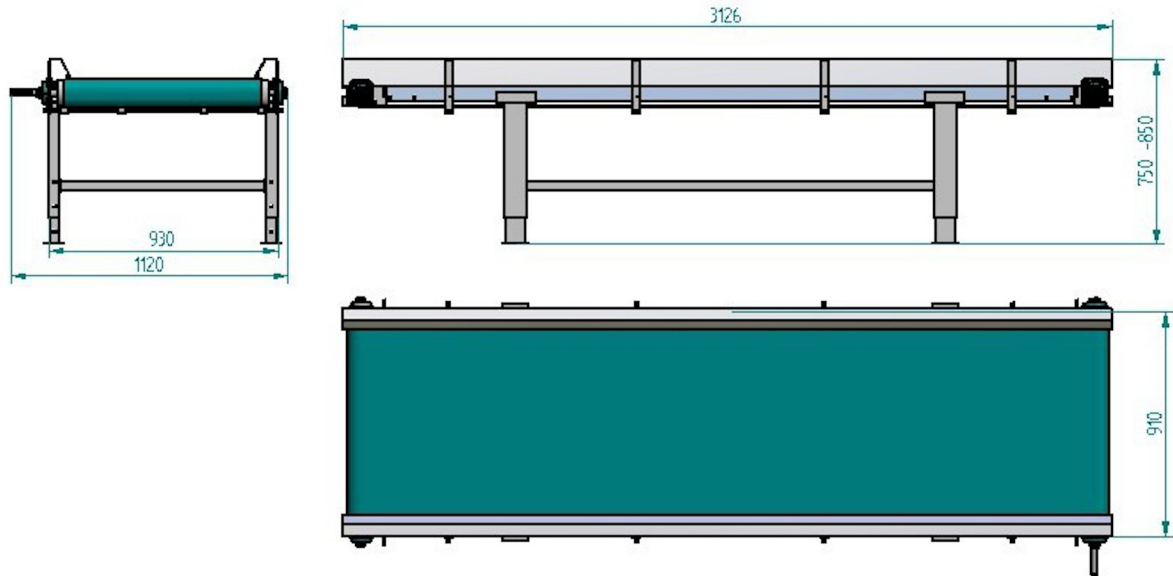

Figure: Dimensions of belt conveyor CONTROL 308

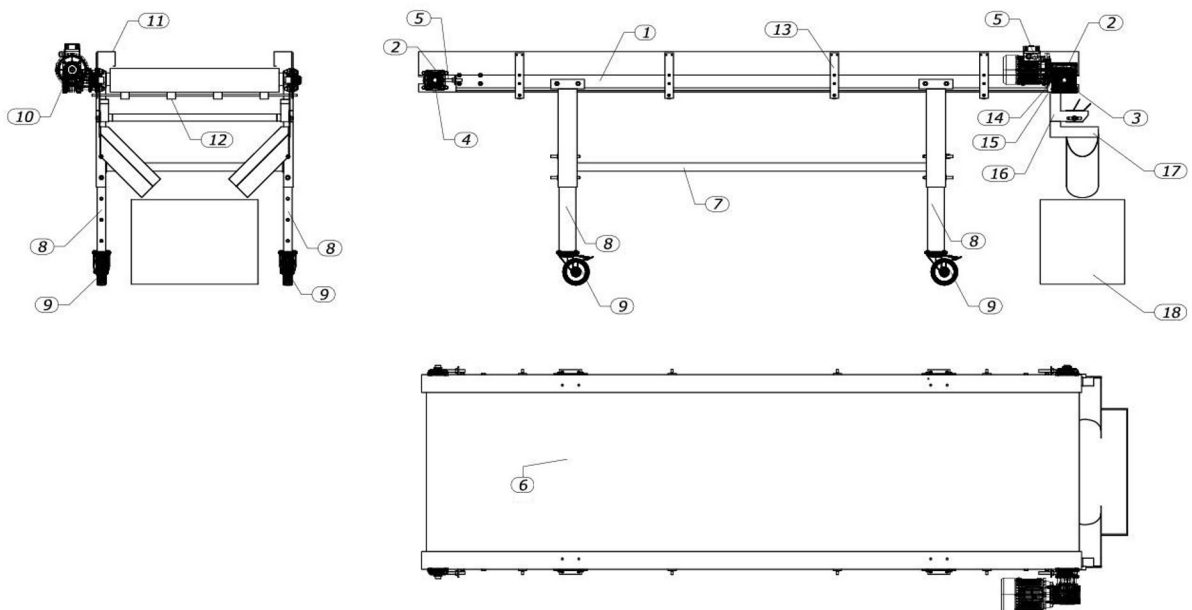

Figure: Appearance of the belt conveyor CONTROL 308

(1) - Upper support structure; (2) - Rolling bearings; (3) - Drive drum; (4) - Tension drum; (5) - Relay mechanism; (6) - Belt conveyor; (7) - Lower support structure; (8) - Telescopic legs; (9) - Wheels; (10) - Electric motor reductor; (11) - Side fence; (12) - Supporting rollers; (13) - Side carrier; (14) - Cleaner driven drum; (15) - Cleaner belt; (16) - Carrier of magnet and magnet; (17) - Concetrator for goods on exit; (18) - Box.

7. Instruction for installation, safety use and maintenance



Only persons instructed to handle, and who are familiar with instructions for use, protective measures and occupational health may operate this machine. Person who runs the machine shall check if all persons around are familiar with instructions and shall remove those who are not.

7.1 Instructions for mounting

Belt transporter rarely operates as an independent machine. It is more often used as an integral part within a line which consists of other machines and devices as well.

Machine is transported to the place of operation. If the machine is an integral part of a line and devices, it is set into the operating position. It may be fixed to the base or to the carrying construction, fixed by bolts. Thereby general safety measures are to be followed.

Space where the machine is set, shall be roofed and to provide enough space around for the operation, supervision and maintenance.

Machine is delivered along with electric feeding cable. Protection system from indirect contact voltage is provided by fuses which are integral parts of electric installation (or a switch board of a plant), onto which the machine is connected. Electric energy supply is foreseen from the network type TN-S or TN-C-S. Circuit switch is mounted on the machine.

Table: Contains minimal diameters of feeding cable.

<i>Nominal output of electric motor, kW</i>	<i>Minimal diameter of feeding cable, mm²</i>	<i>Current of a slow fuse on a feeding network, A</i>	<i>Limit current of a protecting switch***, A</i>
0,55	4x1,5 Cu	4	1,5
0,75	4x1,5 Cu	4	2
1,1	4x1,5 Cu	6	2,7
1,5	4x1,5 Cu	6	3,6
2,2	4x1,5 Cu	10	5,0
3	4x1,5 Cu	10	6,7
5,5	4x2,5 Cu	16*	6,9*

By connecting of electric motor attention must be paid to designated revolutions direction. Reversed revolutions direction may cause improper operation and damages on the machine.



Any intervention inside the distribution cabinet must be performed only by a professional, who is familiar with these instructions and el. scheme which is enclosed. Before any intervention is made inside the distribution cabinet it is important to switch off the main switch, which is lateral on the switch cabinet. In that way the connection from the feeding cable to the network is disconnected. All feeding cables must be protected from mechanical damages by appropriate protection standards!

If your belt transporter is equipped with frequency speed regulator, instructions for operations of the speed regulator must be followed, which are sent along with the machine.

7.2 Instructions for safe operation

Before start up all parts must be checked if they are on right places, especially if machine contains chain transmission its protection cover - 17, figure above. Switch on the line for a short to check if there are some murmurs, which are characteristic for undesirable frictions. It is also important to check whether belt is centered and tightened properly. If any defect is discovered, the line is switched off, supply is disconnected from the network and than intervention may be undertaken.

When it is established that the test operation of the belt transporter is correct, continuous start up may begin and loading of material may start.

If it is required to replace the machine or to change the height of transportation, it is necessary firstly to stop material loading, than wait until the whole material is unloaded from the belt, than the line is switched off and supply from the network is disconnected. After that necessary replacements and adjustments may be performed.

For the usual reload, continuous supervision is unnecessary; temporary supervision is enough. Before finishing the operation stop loading material on the transporter, wait to unload the whole material from the belt and than turn off the line.

7.2.1 Regulation of the inclination angle of the belt



Before you start to change the level of the belt, you must ensure that nobody is in the zone near the transporter and that electric power supply is turned off!



After adjusting the height of the belt conveyor, put the limiting bolts back to their previous positions and retighten them.



7.2.2 Regulation of belt centering

If the belt is not centered along the roller, it is necessary either to loose or to tighten the belts and move the rollers translatory until the centering is reached. After adjustment it is needed to tighten the nuts on the bolts to prevent loosening due to vibrations.

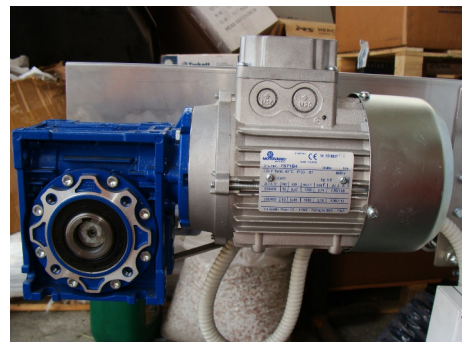
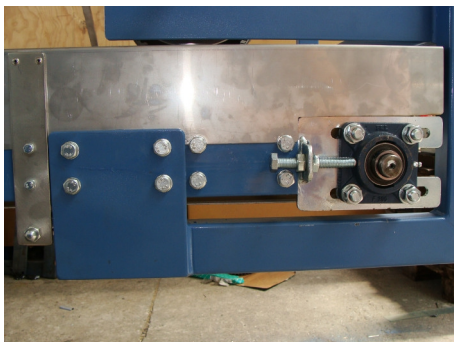
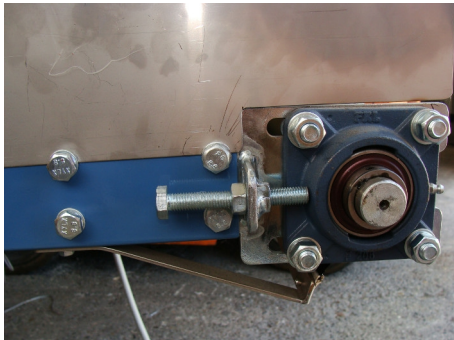

7.3 Instructions for maintenance

- Maintenance consists of regular lubricating and inspection of the device. Before inspection of the transporter it is important to turn the device off, and to disconnect the power supply from the network.
- Lubricant (grease) needs to be squeezed through nipples after every 200 hours of operation, or twice a year. Nipples are built on the casing of the roller bearings, Fig. (2).
- Daily or at least once a week, tightening of transporting belt must be controlled. Thereby machine must be off, it is disconnected from the central power supply. Tightening is performed by moving of tightening drum (4). Fixing nut is loosen (6), so by turning of tightening nut (5), axial distance between driving and tightening drums is increased. In that way the belt is tightened. Thereby it is important to pay attention that nuts on both sides are to be turned for the same number of turns.
- Only in that way axles of driving and tightening drums shall be aligned and belt movement on one side and its damage are prevented. Damaged belt has to be replaced. Contact producer for belt replacement. By the belt replacement producer shall control side bearings of the driving drum as well as the bearings of the tightening drum.
- Every second year contact producer to change oil in the reducer.



Only professionals who are familiar with these instructions may perform maintenance of the belt transporter. Before control and during maintaining the machine needs to be off and power supply disconnected. After control protecting cover is to be returned to its place. **Operation without the cover might cause injuries!**

7.4 For your safety

- **For your safety**
Stop the el. power supply before the maintenance
Stop the electric supply before you start the maintenance works. It is impossible to exclude damages on the electric system.
- **Electric motor**
Maintenance works related to the motor is conducted according to the motor producer
- **Special safety information**
Only perform the maintenance operations if you have the required expert knowledge and suitable tools. A lack of specialist knowledge or the use of unsuitable tools can cause accidents.
- **Always use original spare parts**
Always use original spare parts for components which are important for the safe operation. Dimensions, strength and quality of material must be guaranteed. If original spare parts are not installed, safe operation cannot be guaranteed.

- **Protect the device from inadvertently starting**

Maintenance and the correction of faults on the coupled machine may only be performed with the engine turned off, the ignition key removed and the electronic control system switched off! Severe accidents can result if the device starts inadvertent.

7.5 List of spare parts

- The machine is designed to be long-lasting and replace only after long-term use. Parts that are subject to change are replaced and treated as consumables are given in the tables.

7.5.1 Spare parts for CONTROL 308 (RN1132/16)

<i>No.</i>	<i>Code</i>	<i>Description</i>	<i>Number of installed parts on the machine</i>
1	335665	Magnetic plate f 34x860 GM PMR	1,00
2	334009	Display and keys for VFD-E series KPE-	1,00
3	331944	Flange outlet NMRV 050 FA	1,00
4	333138	Worm reducer NMRV 050 050 PA	1,00
5	333432	Frequency regulator Delta 0.75kW / 4.2	1,00
6	334916	Drum drive f 108	1,00
7	334917	Tightening drum f 108	1,00
8	331822	Bearing 6000 2rs cx	32,00
9	333656	Bearing housing F 206 FKL	2,00
10	333655	Bearing LE 206 2F.Y FKL	2,00
11	33258	Bearing UCF 205	2,00
12	336402	Conveyor belt pvc 800x6300 AS FG v.	1,00

8. Eliminating malfunctions

- Malfunctions can often be eliminated quickly and easily. Please read the associated safety information.

<i>Malfunction</i>	<i>Cause</i>	<i>Remedy</i>
Electric motor can not start	Supply failure or break down on the electric motor	Connect the supplying cable
		Check the fuse
		Contact the producer

9. Disposing of the machine

When the service life of your machine is over, it must be properly disposed of. Please observe the current and valid waste disposal regulations.

- **Metal parts**

All metal machine components can be sent for ferrous metal recycling.

- **Rubber**

Rubbers can be sent to rubber recycling facilities.

- **Electronics**

PCB s and terminals of the electronic sowing unit control system are considered to be scrap electronic material and should be disposed of with special waste. Should there be no special waste handling facility in your area, you can return the electronic components to the manufacturer for proper disposal. It will then be disposed of in an environ- mentally-friendly manner.



<http://www.euoprima.rs/>