



A.T.S.

Automatic Transfer Switch panel

ATS Control panel is designed for mains/generator transfer switch applications which involves a genset usually equipped with an automatic control panel.

The ATS control panel comprises all circuits, devices and controls which enable the switch between the mains and the genset, in order to supply the load in case of mains failure.

The ATS control panel is made with a steel sheet subjected to a painting treatment using high resistance epoxy powder.

The power circuit is safety split from the control area in accordance to the main operation rules.

The grade protection is IP20 with opened door. With closed door is IP55 or IP40 based on the type of carpentry used.

Related to the power of genset, the power circuit is composed by a couple of interlocked contactors (up to 125A included) or a motorized changeover switch, in both cases 4 poles.

In addition, it's available a version of ATS with the power circuits equipped with 2 (two) automatic, interlocked and motorized circuit breakers

Benefits:

- Most quality parts
- Made in Italy

TWO TYPES OF ATS CONTROL PANEL ARE AVAILABLE:

“BASIC” VERSION: It’s a manual ATS Control panel (without any microprocessor controller) equipped with a 4 positions switch selector with AUTOMATIC – 0 – MAINS – GENSET and 2 (two) lamps for optical signalling (Load supplied by the Mains) and “Load supplied by the Genset”. Fuses protections and terminal boards are available as well. This type of ATS panel is usually combined to a local genset control panel.

“LOGIC” VERSION: It’s an automatic ATS Control panel equipped with microprocessor based controller having a graphical display which allows to show voltages, frequency, working hours and the battery voltage of the genset. This type of ATS panel is able to control automatically the switch Mains/Genset (*it’s particularly used if combined with Caterpillar, FG Wilson gensets*).

The LOGIC ATS panel supports a microprocessor based controller, available in two versions: **ATS115** and **ATS115^{Plus}**.

As option, it’s possible to add 3 current transformers in order to enable the current measure, power and cosφ.

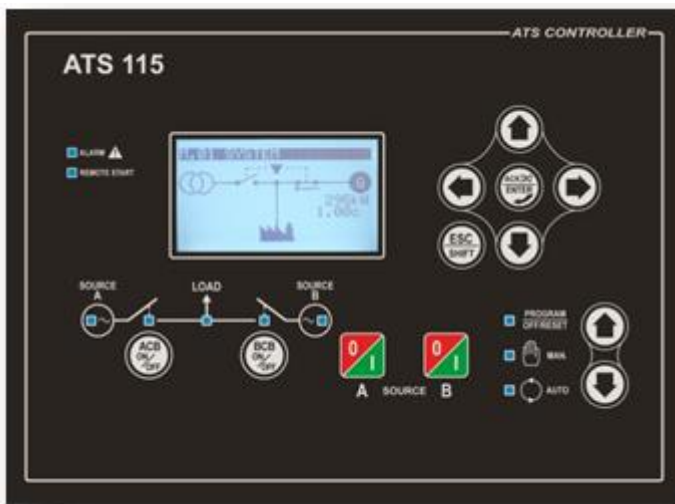

Features:	BASIC VERSION	LOGIC VERSION
Power Terminal board Mains/Genset/Load	YES	YES
Selector switch Mains – Automatic – 0 – Genset	YES	NO
Keyboard with push buttons for the mode/control selection	NO	YES
Optical signal with lamp/led to advise the load is supplied by the Mains	YES	YES
Optical signal with lamp/led to advise the load is supplied by the Genset	YES	YES
Fuses for protections	YES	YES
Adjustable three-voltage relay Mains and Genset voltage	NO	YES
Microprocessor controller	NO	YES
Voltmeter for Mains voltage: Phases L1-L2/L2-L3/L1-L3	NO	YES
Mains and Genset frequency meter	NO	YES
Battery voltage meter	NO	YES
Working hour meter	NO	YES
Current transformers for the activation of currents, power and cosφ measurement	NO	OPTION (*)
Automatic battery charger	NO	OPTION

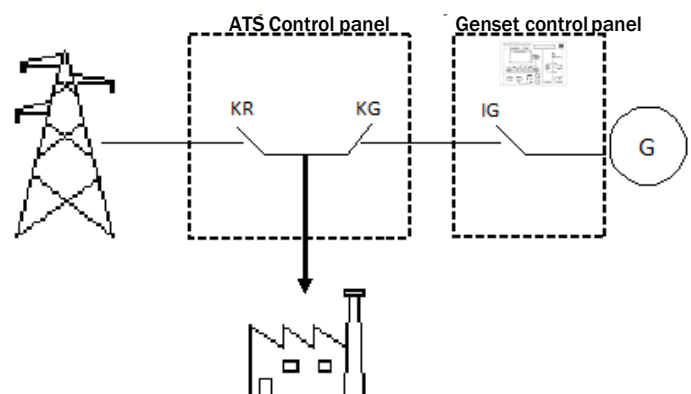

IN CASE OF ATS PANEL LOGIC VERSION

Controls

- START Engine start push-button
- STOP Engine stop push-button
- ACK Acoustic alarm silencing push-button
- UP/DOWN push buttons for display selection
- MCB push-button
- GCB push-button
- Four ARROW keys for LCD display selection mode, window selection, parameter change and other
- EXIT, ENTER keys. Dead key SHIFT
- Emergency stop push-button
- The control system includes an easy-to-use, full function operator panel and LED annunciators. The keyboard of the microprocessor controller is used to select the different operation mode: off/reset/ program, manual, automatic. Fuses on the front for an easy replacement, when needed.

Measures

Mains Voltage:

L1-N, L2-N, L3-N, L1-L2, L2-L3, L3-L1

True measure calibrated to RMS. Lx-N

max. voltage < 300Vac cat. IV High

voltage pulse = 6kV 1.2/50 us

Max. measurable voltage = 25.000V (by external TV).

Generator Voltages:

L1-N, L2-N, L3-N, L1-L2, L2-L3, L3-L1

True RMS measure.

Lx-N max. voltage < 300Vac cat. IV

High voltage pulse = 6kV 1.2/50 us

Max. measurable voltage = 25.000V (by external TV).

Generator Currents (*Optional in case additional current transformers*):

L1, L2, L3, N

True RMS measure.

Nominal max. current: 5Aac

Overload measurable current : 4 x 5Aac (sinusoidal).

Internal current transformer.

Max. nominal current = 6000A (by external TA).

Generator and Mains Frequency meter:

Resolution = 0.1 Hz.

Accuracy = ± 50 ppm, ± 35 ppm/°C (typical)

Battery Voltmeter:

Resolution = 0.1V

Oil Pressure Gauge:

VDO 0-10 Bar, VDO 0-5 Bar, Veglia 0-8 Bar

(settable curves using BoradPRG3)

Water Thermometer:

VDO, Veglia

(settable curves using BoradPRG3)

Fuel Level:

VDO, Veglia

(settable curves using BoradPRG3)

Engine revolution counter:

By pick-up. Programmable teeth number.

Same input can be used by W signal.

Power and power factor measures are available as total measure and also for each single phase.

Maximum power and current reached values, are memorized with date and time.

Protections

A set of high efficiency led are used to inform the current status of the Generator Set and for the visualization of any alarm. Secondary alarms are represented by their corresponding display code.

Status

- Mains live
- Generator live
- Mains contactor closed
- Generator contactor closed
- Engine running
- Engine Cooling
- Engine start and stop

Engine protections

- Fuel reserve
- Max./Min fuel level
- Battery failure (min./max. Voltage)
- Min. oil pressure
- Max. engine temperature
- Closing of mains contactor or gen set contactor failed
- Engine over crank
- Over speed (electronic from generator frequency or from pick-up)
- Generator overload (from external contact of circuit breaker)
- Belt breakage
- Operating conditions not reached
- Emergency Stop

Generator protections

- Underfrequency (81U)
- Overfrequency (81O)
- Undervoltage (27)
- Overvoltage (59)
- Power direction (32)
- Time dependent overcurrent (51)
- Instantaneous overcurrent (50)
- Phase sequence (47)
- Current (46) and Voltage (47) unbalance

Additional information are available on the display to show measures, cumulative alarms not listed above.

Mains protections

- Mains voltage Max./Min.
- Mains frequency Max./Min.
- Mains failure
- Phase sequence
- Phase asymmetry

Communication:

- N.1 USB port

Optional:

- N.1 RS232 serial port Modbus RTU (ATS115^{Plus})
- N.1 RS485 insulated serial port Modbus RTU (ATS115^{Plus})
- N.1 RJ45 ETHERNET serial port TCP/IP (ATS115^{Plus})
- Insulated CANJ1939 (ATS115^{Plus})
- Direct management PSTN and GSM
- Rewind for GSM/GPRS/GPS control
- Automatic battery charger (check the carpentry dimensions)

Additional features:

- Engine diagnostic code
- Periodical test
- Real Time Clock
- Pre-glow and coolant heater management
- Remote start and stop
- Maintenance working
- Embedded alarm horn
- Password protected access for adjust the operating parameters
- Graphic display 70x38mm - 128 x 64 pixel
- LCD: transfective with LED backlight
- Multilanguage device: ITA, UK, FR, RU, PT/BR

Additional technical features:

- Supply voltage: 230 ÷ 400 Vac (other to be specified)
- Available also multiple voltages version: 440 / 400 / 230V.
- Auxiliary voltage: 12 Vdc or 24 Vdc
- Frequency: 50 Hz or 60 Hz
- Insulation: > 50 Mohm
- Dielectric strength AC: 2500V/1'
- Dielectric strength DC: 1000 V/1'
- Level of protection: IP40 or IP55 (Logic version)
- Colour: RAL7035
- Ambient temperature: - 20° to + 60 °C
- Conforming to CEI – IEC – EN rules:
 - 2006/95/CE – LOW VOLTAGE DIRECTIVE
 - 2004/108/CE – EMC DIRECTIVE
 - 93/68/CEE – CE STAMP REGULATION
- ATS panel is designed and manufactured in ISO9001 certified facility

