



stratasys

Fortus® 380/450mc

K5/K0 Series

SITE PREPARATION GUIDE

COPYRIGHT

Copyright © 2018-2022 Stratasys Ltd. All rights reserved.

This documentation contains proprietary information of Stratasys Ltd. This information is supplied solely to assist authorized users of this Stratasys 3D printing system. No part of this document may be used for other purposes, and it may not be disclosed to other parties. The specifications on which this document is based are subject to change without notice. No part of this book may be reproduced in any form or by any means, nor stored in a database or retrieval system, without prior permission in writing from Stratasys Ltd.

If this document is distributed as a PDF file, you may print it for internal use.

LIABILITY

Stratasys shall not be liable for errors contained herein or for incidental or consequential damages in connection with the furnishing, performance, or use of this material. Stratasys makes no warranty of any kind with regard to this material, including, but not limited to, the implied warranties of merchantability and fitness for a particular purpose. It is the responsibility of the system owner/material buyer to determine that Stratasys material is safe, lawful, and technically suitable for the intended application as well as identify the proper disposal (or recycling) method consistent with local environmental regulations. Except as provided in Stratasys' standard conditions of sale, Stratasys shall not be responsible for any loss resulting from any use of its products described herein.

TRADEMARKS

Stratasys, Insight, FORTUS, and FDM are registered trademarks of Stratasys, Inc.

FORTUS 380mc and 450mc are a registered trademark and service mark of Stratasys Inc. in the United States and other countries.

ULTEM™, 9085 and 1010 are trademarks of SABIC, its affiliates or subsidiaries.

All other product names and trademarks are the property of their respective owners, and Stratasys assumes no responsibility with regard to the selection, performance, or use of these non-Stratasys products. Product specifications subject to change without notice.

TABLE OF CONTENTS

ABOUT THE FORTUS 380MC & 450MC.....	1
COMPONENTS.....	1
380mc Highlights	1
450mc Highlights	1
HOW TO USE THIS GUIDE.....	1
SITE PREP TASKS	2
SELECTING THE SITE.....	2
SPACE REQUIREMENTS	2
Dimensions and Weights	2
Minimum Clearances	3
ENVIRONMENTAL REQUIREMENTS	4
Heat Output	4
Power Consumption	4
ELECTRICAL REQUIREMENTS	4
AC Power Requirements	4
Optional UPS Connectivity	5
Optional AC Transformers.....	5
LAN REQUIREMENTS	7
RECEIVING THE PRINTER.....	7
INSPECT CRATE FOR DAMAGE	7
PREPARING FOR INSTALLATION	8
REQUIRED TOOLS AND EQUIPMENT	8
UNPACKING THE PRINTER	8
Remove Shipping Materials.....	8
Remove Printer from Shipping Base - Fork Lift Instructions.....	10
Remove Printer from Shipping Base - Ramp Instructions	11
Removal of Rear Panels and Cover	13
SERVICE CONNECTIONS	16

REVISION LOG



Note: Translations of this guide are updated periodically. If you are consuming a translated version, please check the English version for the latest revision and list of updates.

The following table lists the main changes in each revision of the document.

Revision	Date	Description of Changes
821465-0001, Rev. A	August 2014	Initial release.
821465-0002, Rev. A	October 2014	Added 380mc information throughout.
821465-0003_REV_A	August 2015	Added air quality information to the Environmental Requirements section.
821465-0004_REV_A	November 2015	Added ULTEM 1010 resin information throughout. Updated document branding per new Stratasys design and guidelines.
821465-0005_REV_A	November 2015	Revised the information pertaining to moving the printer.
821465-0006_REV_A	January 2016	Revised the information pertaining to removing shipping materials.
821465-0007_REV_A	October 2016	Added Optional UPS information.
821465-0007_REV_B	July 2022	Updated SABIC trademarks and statement.

SAFETY

The following basic safety tips are given to ensure safe installation, operation, and maintenance of Stratasys equipment and are not to be considered as comprehensive on matters of safety. Although the Fortus 380mc and 450mc are designed to be safe and reliable printers, access to areas of the printer are potentially dangerous.

SAFE ENVIRONMENT

- Connect equipment to a grounded facility power source. Do not defeat or bypass the ground lead.
- Know the location of equipment branch circuit interrupters or circuit breakers and how to turn them on and off in case of emergency.
- Know the location of fire extinguishers and how to use them. Use only ABC type extinguishers on electrical fires.
- Know local procedures for first aid and emergency assistance at the customer facility.
- Use adequate lighting at the equipment.
- Maintain the recommended range of temperature and humidity in equipment area.
- Do not use this product in an environment containing volatile or flammable compounds.

ABOUT THE FORTUS 380MC & 450MC

The 380mc and 450mc printers incorporate the latest in innovative technologies to provide you with precise prototypes from a CAD design. Stratasys' Fused Deposition Modeling (FDM) technology provides prototype parts, including internal features, that can be used to field-test form, fit, and function. Direct Digital Manufacturing (DDM) allows for the creation of customized end-use parts straight from 3D CAD data. The 380mc/450mc features a servo/belt driven XY gantry with multiple high temperature modeling material capability.

COMPONENTS

- The 380mc or 450mc Printer (depending on model purchased)
- Material Package(s)
- Welcome Kit (containing your user documentation, software CDs, common tools for maintaining the printer, and a variety of replacement parts)
- A Computer Workstation (not sold by Stratasys)

380MC HIGHLIGHTS

- Maximum build area of 14 x 12 x 12 inch (356 x 305 x 305 mm)
- Material Canister Bays: 1 model, 1 support
- Touchscreen Graphical User Interface

450MC HIGHLIGHTS

- Maximum build area of 16 x 14 x 16 inch (406 x 356 x 406 mm)
- Material Canister Bays: 2 model, 2 support
- Touchscreen Graphical User Interface

HOW TO USE THIS GUIDE

This guide provides information for selecting an appropriate location for the Fortus 380mc/450mc. Instructions and specifications pertain to both the 380mc and 450mc model, unless otherwise stated. This guide also provides instructions for unpacking and preliminary set-up. Information of particular importance is presented in one of three formats:



Warning: A WARNING indicates a procedure that may cause injury to an operator if the procedure is not followed.

A WARNING will precede the paragraph of instruction to which it relates.



Caution: A CAUTION indicates a procedure that may cause damage to equipment if the procedure is not followed.

A CAUTION will precede the paragraph of instruction to which it relates.



Note: A NOTE is used to highlight a specific point or to provide an operational tip. While useful, a NOTE does not indicate a procedure that can cause injury or damage if it is not followed.

A NOTE will follow the paragraph of instruction to which it relates.

SITE PREP TASKS

SELECTING THE SITE

Decide where to install the printer based on the following:

1. Space Requirements
2. Environmental Requirements
3. Electrical Requirements
4. LAN Requirements



Note: The 380mc and 450mc are capable of generating vibrations depending mainly on part build geometry and material characteristics. This consideration will need to be taken into account if locating the printer near vibration sensitive equipment.

SPACE REQUIREMENTS

DIMENSIONS AND WEIGHTS

Make sure that the installation site floor space can accommodate the printer's weight and dimensions, plus required clearances.

Crated	Width: 60.0 inches (152.40 cm) Depth: 45.9 inches (116.59 cm) Height: 87.0 inches (220.98 cm)
Uncrated	Width: 51.0 inches (129.5 cm) Depth: 35.5 inches* (90.2 cm) Height: 78.1 inches** (198.4 cm)
Shipping Weight	1500 pounds (680 kg)
Printer Weight	1325 pounds (601 kg)

* The printer can be moved through a standard 36 inch (91.44 cm) door opening with exterior panels and covers installed. An absolute minimum depth of 34 inches (86.36 cm) can be achieved through removal of the rear service access panels and top cover. See ["Removal of Rear Panels and Cover"](#) on page 13 for instructions.

** An absolute minimum printer height of 73 inches (185.42 cm) can be achieved through the removal of several structural components by a qualified 380/450mc Service Representative. Refer to Service Bulletin SB00254 for details of required disassembly.

MINIMUM CLEARANCES

Side Clearance	Minimum 30 inches (76.20 cm) on each side
Rear Clearance	Minimum 12 inches (30.48 cm)
Front Clearance	Minimum 36 inches (91.44 cm)
Overhead Clearance	Minimum 24 inches (60.96 cm)

Figure 1: Minimum Clearances

24 inches (60.96 cm) minimum for overhead clearance

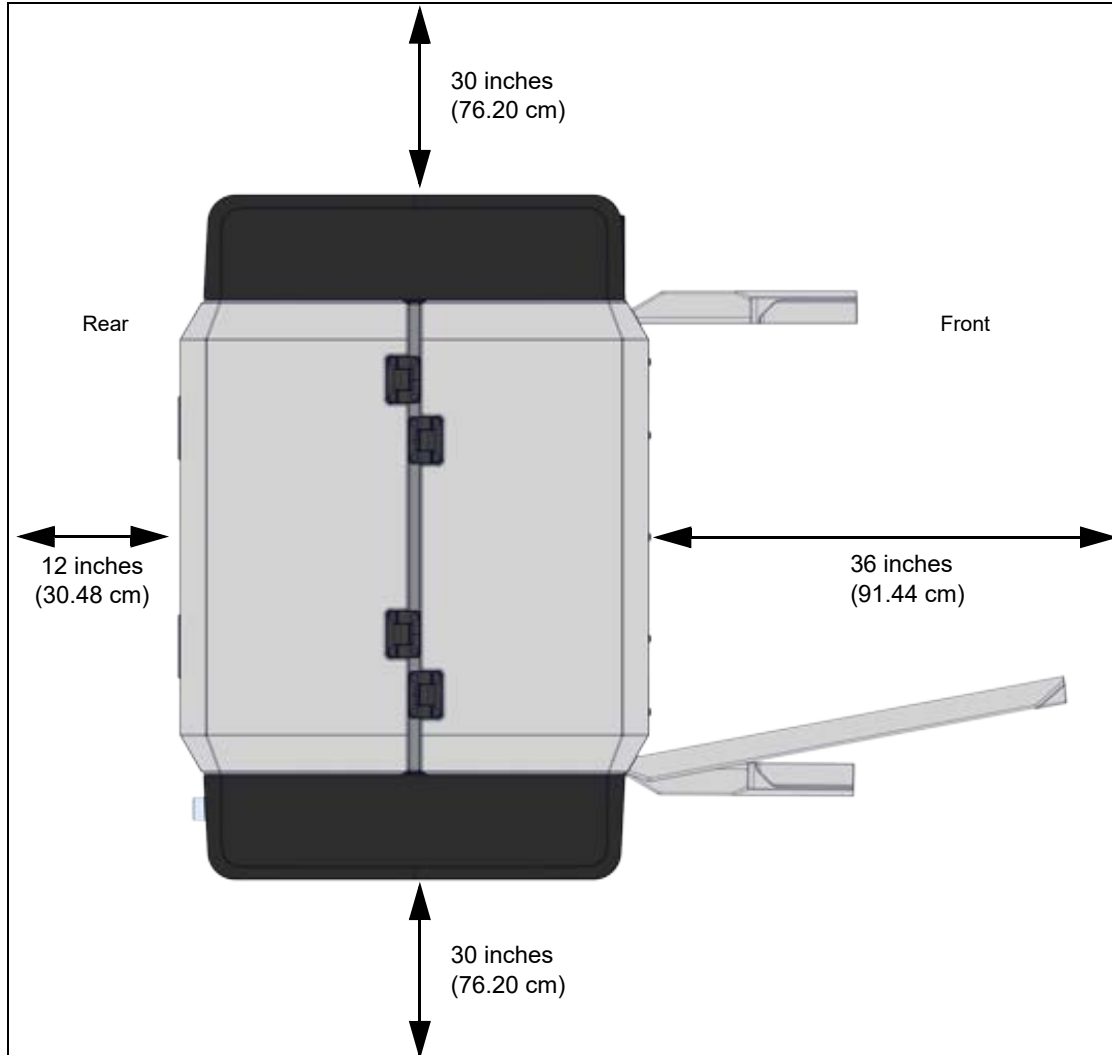

ENVIRONMENTAL REQUIREMENTS

- The 380mc and 450mc are for indoor use only.
- Air quality conditions with excessive solid particulates (conductive or non-conductive) may result in system damage.
- Air quality conditions in which airborne oils are allowed to accumulate on or within the printer can damage the plastic components.
- Operating temperature shall be in the range of 65°F to 86°F (18°C to 30°C), with relative humidity range of 30% to 70% non-condensing.
- Storage temperature shall be in the range of -40°F to 129.2°F (-40°C to 54°C), with relative humidity range of 10% to 85% non-condensing.
- Altitude shall not exceed 6561.68 feet (2000 m).
- Noise emission (acoustic):
 - <65dBA when idle
 - <66dBA when building

HEAT OUTPUT

Heat dissipation occurs mostly through the top of the printer. Heat output is material dependent due to the various temperatures maintained in the build chamber.

Material Type	Heat Output (while building)	Heat Output (while idle)
ABS	~8,000 BTU/hr	~7,000 BTU/hr
PC	~12,500 BTU/hr	~11,500 BTU/hr
ULTEM™ 9085 resin	~15,500 BTU/hr	~14,500 BTU/hr
ULTEM 1010 resin	~19,900 BTU/hr	~18,550 BTU/hr

POWER CONSUMPTION

Power consumption is material dependent due to the various temperatures maintained in the build chamber.

Material Type	Power Consumption (while building)	Power Consumption (while idle)
ABS	2250W	2050W
PC	3550W	3000W
ULTEM 9085 resin	4500W	4200W
ULTEM 1010 resin	5850W	5450W

ELECTRICAL REQUIREMENTS

AC POWER REQUIREMENTS

- 50/60 Hz 5 wire (LLL+N+PE) dedicated circuit.
- Voltage: 120/208 VAC 3 phase nominal.
- Current: 18A.
- In-rush: 50 Amps max for less than 10 milliseconds, 21 Amps max for less than 20 seconds.
- Maximum input voltage variation: ±10% of nominal.
- Leakage (touch) current: <1.0mA (under all conditions), 0.0mA (when OFF).

Operation of the printer outside this range is not recommended; degradation of performance and shortened component life expectancy will be experienced. The printer is to be operated on a 3-phase service meeting the recommendations for power quality given in IEEE Standard *141-1993. Facilities who are unsure of their power quality should contact their service provider.

* IEEE Standards licensing rules prohibit Stratasys from distributing the Standard. End users who wish to review the Standard are responsible for its individual purchase.

OPTIONAL UPS CONNECTIVITY

A connector at the rear of the printer is provided allowing an external UPS to initiate the safe shutdown of the printer. At a minimum the external UPS should meet the following minimum requirements:

- Output power rating: $\geq 10\text{KVA}$
- Output waveform: sine-wave
- Run time: UPS must be rated to provide a minimum of 7 minutes of battery operation.



Note: Stratasys does not recommend external UPS makes or models. Additionally, the cable and connector interfacing the UPS to the printer is the responsibility of the UPS supplier and/or end user.

About the printer UPS connector:

- The UPS connector is located in lower most position of the rear connection plate. See [Figure 2](#).
- The printer's connector profile is female D-Sub 9 pin; this is NOT a serial communication port.
- Only pins 7 and 9 of the connector are used with remaining pins having no internal connections.
- When the circuit between pins 7 and 9 is open ($>5000\text{ohms}$) the printer operates normally.
- Closing the circuit ($<400\text{ohms}$) between pins 7 and 9 initiates a safe shutdown process as if the front power off button was depressed.

Figure 2: UPS Connections

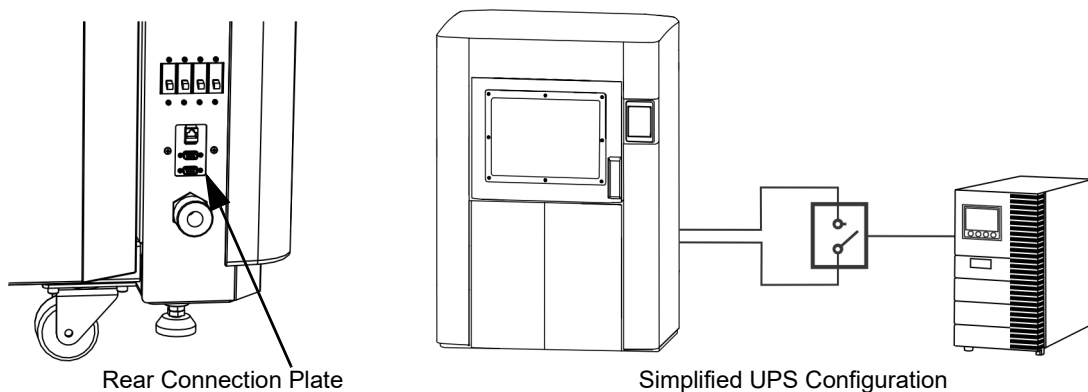

OPTIONAL AC TRANSFORMERS

Two optional AC transformers are available from Stratasys for facilities with AC electrical services outside of the 208 VAC specification. The transformers meet applicable electrical and safety standards and carry both the CE Mark and the Mark of a Nationally Recognized Test Laboratory (NRTL) for North America.

A transformer electrical wiring diagram, for use by a qualified electrician, is located within the transformer.

Transformer PN	Specifications	Weight
155-01200	8.0 KVA 200-240 VAC 50/60 Hz Delta-Wye	195 pounds (88 kg)
155-01400	8.0 KVA 380-480 VAC 50/60 Hz Delta-Wye	200 pounds (90 kg)

**Figure 3: Transformer Dimensions & Mounting Specifications
(applicable to both transformers)**

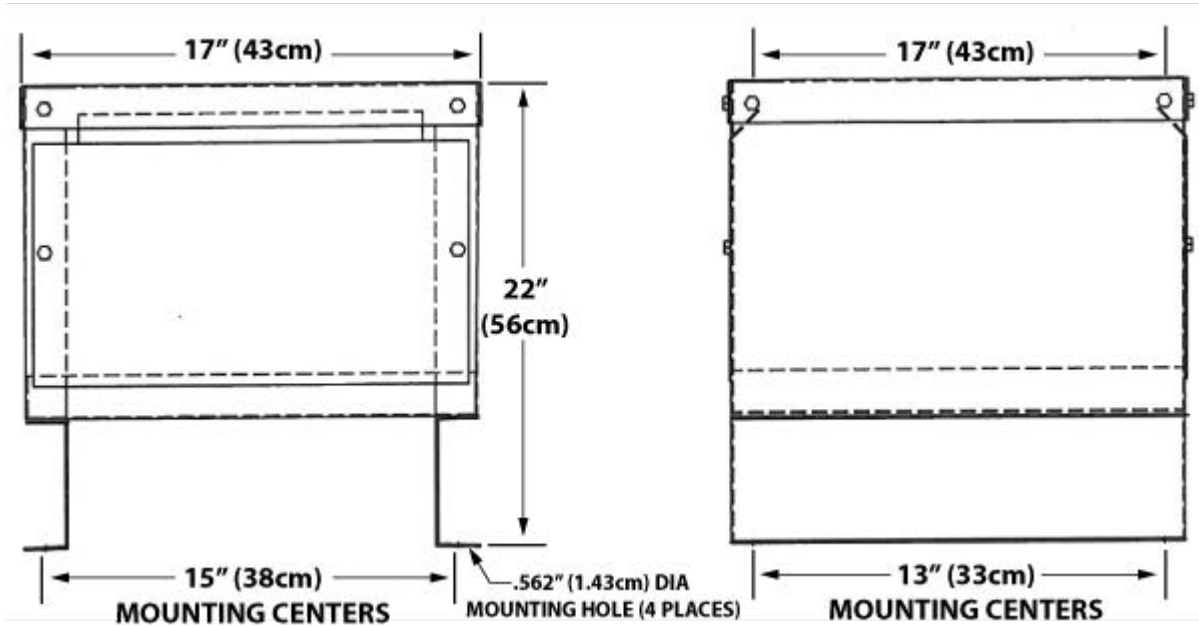

When configuring the transformer for different input voltages, the internal tap 1 connection wires (typically colored yellow, red and orange) must be moved to the appropriate tap position (terminal block number) shown on the connection diagram attached to the inside cover of the transformer. 3 phase input is connected to the same terminal block positions as the tap 1 connection wires, per the connection diagram (see [Figure 4](#) for an example).

Figure 4: Internal Jumper Configuration

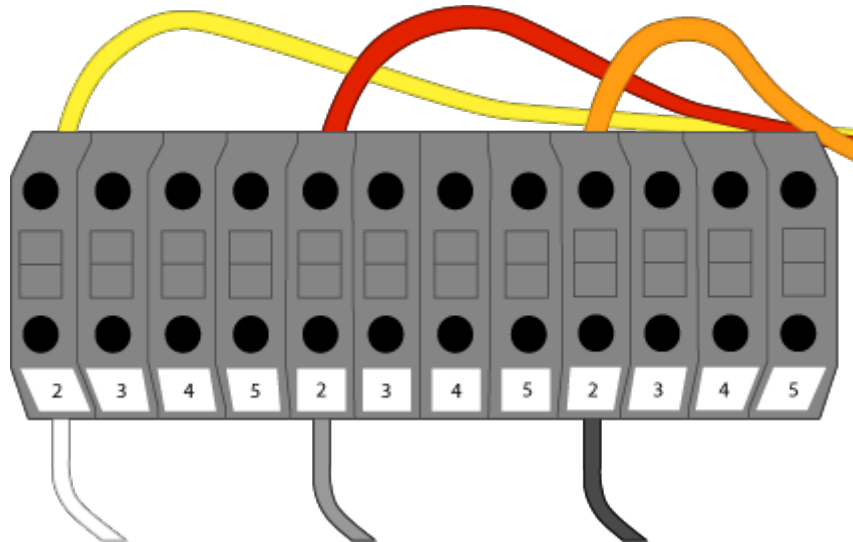

LAN REQUIREMENTS

A LAN connection is required for communication and file transfer functions.

The LAN connection is a 100 base T, Ethernet protocol, RJ45 connector. One 25 foot (7.62 m) CAT5, 10/100 base T cable is supplied with the printer, located in the Startup Kit.

The printer will function in either DHCP or Static IP configurations.



Note: Printers configured with a network option of UPnP=ON will occasionally broadcast a unique system identifier across the network for use by the Insight FDM Control Center software application.

Refer to Insight's user information for workstation requirements.

RECEIVING THE PRINTER

INSPECT CRATE FOR DAMAGE

Before opening the shipping crate, inspect the crate for signs of exterior damage.

Report evidence of excessive damage to Stratasys and the shipping company.

PREPARING FOR INSTALLATION

REQUIRED TOOLS AND EQUIPMENT

- Basic hand tools (powered screwdriver or drill with Phillips bit).

UNPACKING THE PRINTER



Note: If you intend to remove the printer from its shipping base via the ramp, ensure that there is sufficient clearance for the ramp to be lowered before you begin the process of unpacking the printer. The printer's shipping base indicates the location of the ramp.

REMOVE SHIPPING MATERIALS

1. Inspect the Tip Indicators (2) and ShockWatch indicator affixed to the exterior of the cardboard box. If possible, take a picture of these indicators to share with your installation representative. If damage is detected upon installation, this photo will assist your installation representative in determining the cause of damage (Figure 5).
2. Using a Phillips screwdriver, remove the cover mount screws from the base of the crate (Figure 5).

Figure 5: Shipping Crate Detail

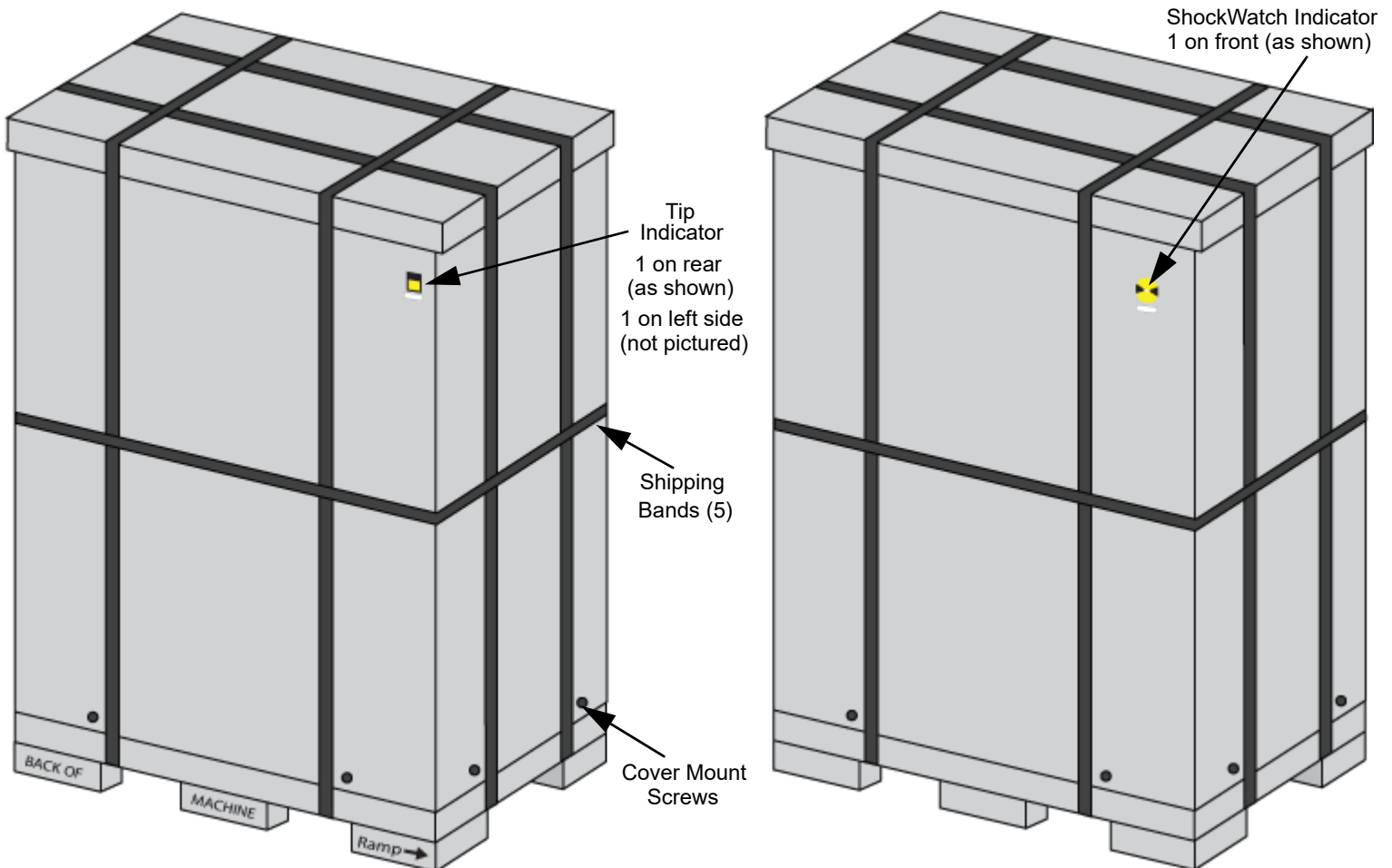



Warning: Shipping bands are very tight; when cutting shipping bands they may pop open with force. Wear safety glasses when removing the shipping bands.

3. Carefully cut the shipping bands (Figure 5).
4. Remove the cardboard cover from the top of the crate and then remove the foam restraining insert (Figure 6).
5. Remove the 2 protective cardboard container panels (Figure 6).
6. Carefully tear away all clear plastic wrapping.

Figure 6: Unpacking the Printer (cover removed)

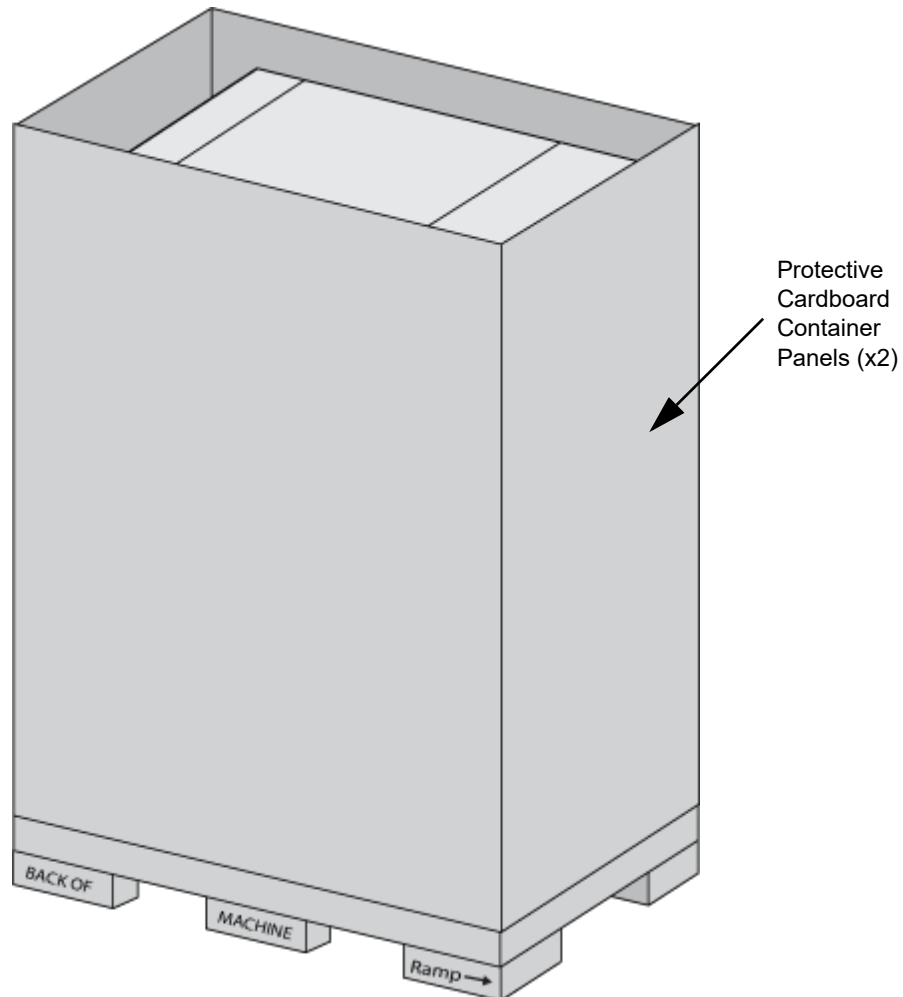

7. Remove the printer from the shipping base, this can be done using a fork lift (see [“Remove Printer from Shipping Base - Fork Lift Instructions”](#) on page 10) or manually via the use of a ramp (see [“Remove Printer from Shipping Base - Ramp Instructions”](#) on page 11).

REMOVE PRINTER FROM SHIPPING BASE - FORK LIFT INSTRUCTIONS



Caution: Use care when cutting the plastic bag to avoid scratching the printer's surfaces.

1. Remove all tape and carefully cut the plastic bag encasing the printer. Unwrap the printer by pulling the plastic bag downward.
2. Ensure that the bag is not blocking the fork lift openings or the printer's casters. If needed, cut away the plastic bag's material from these locations.



Caution: Access the fork lift openings from the back of the printer ([Figure 7](#)).

3. Using a forklift, carefully raise the printer vertically and remove the shipping base.

Figure 7: Opening for Forks

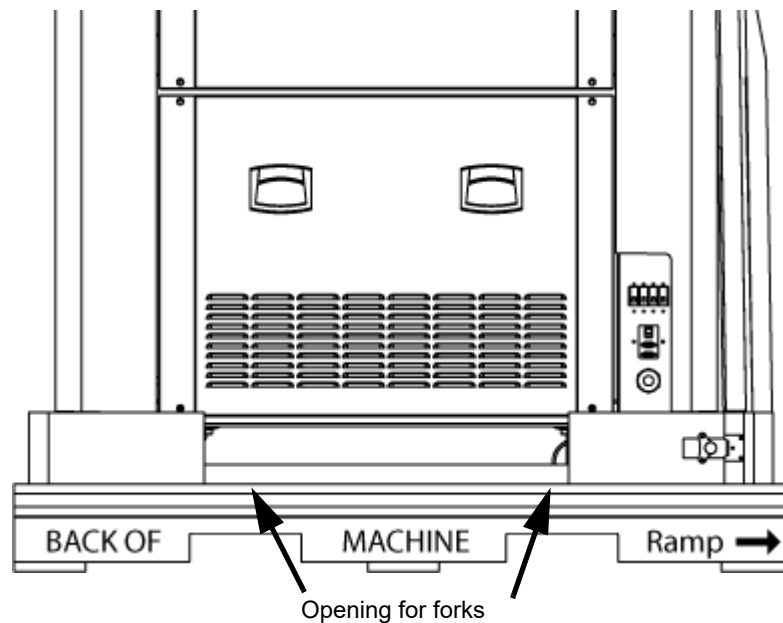

4. Gently lower the printer, until it rests on its casters.
5. Inspect the printer's exterior for dents and scratches. Immediately report any damage to Stratasys and the shipping company.
6. Roll the printer into its approximate operating location.



Note: Position the printer to allow at least three feet of clearance on all sides until the installation process is complete, see "[Space Requirements](#)" on [page 2](#). Final installation and setup must be accomplished by a qualified service representative.

REMOVE PRINTER FROM SHIPPING BASE - RAMP INSTRUCTIONS



Warning: Before removing the printer via the ramp, ensure that you have enough manpower to remove the printer from the shipping base, as the printer is heavy (see “Dimensions and Weights” on page 2). A minimum of 3 capable adults should be used to remove the printer from the shipping base.

1. Unlatch the two link locks securing the ramp in a vertical position (Figure 8), and gently lower the ramp onto a level surface (Figure 9).

Figure 8: Ramp Hardware (viewed from side)

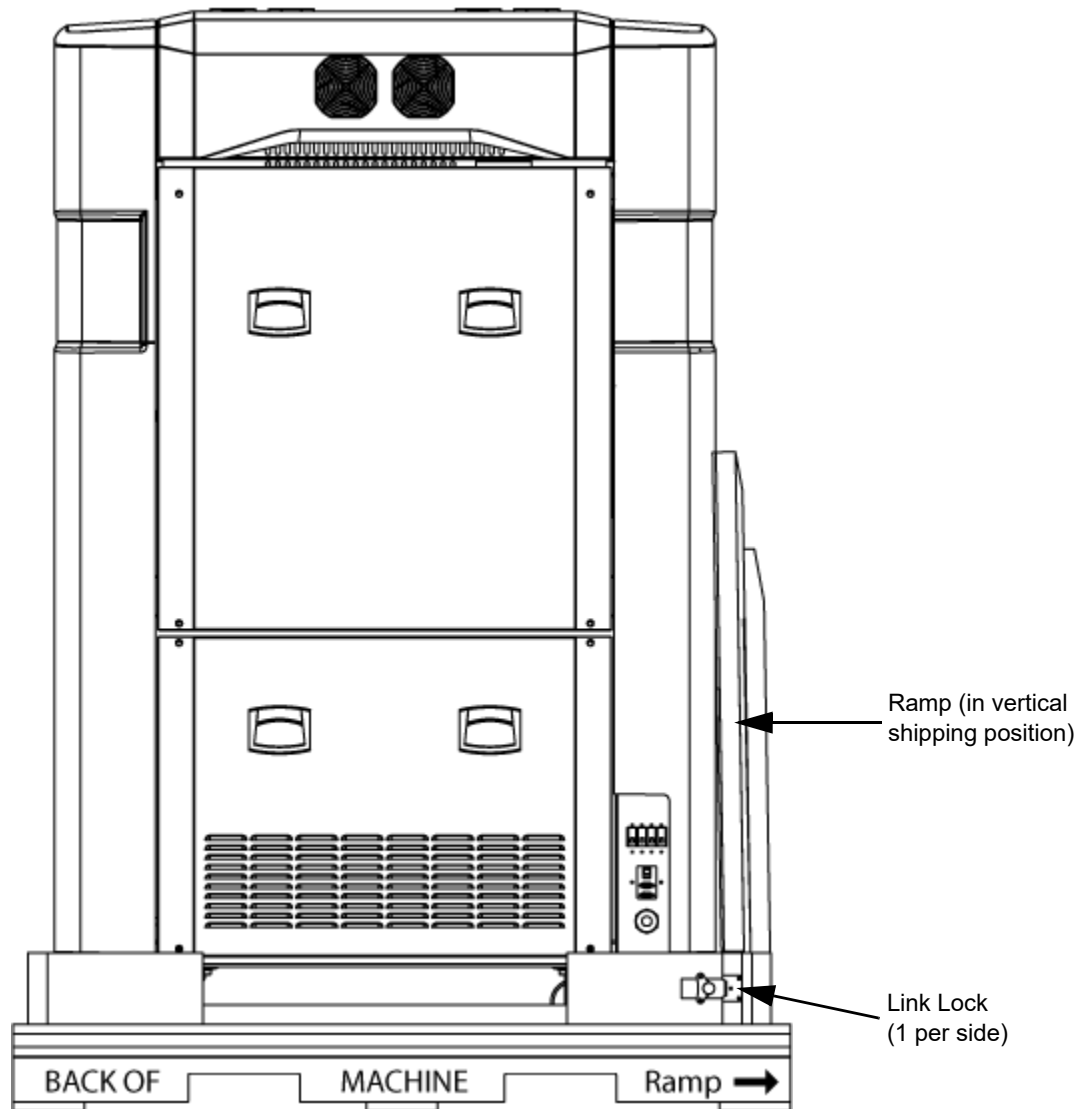
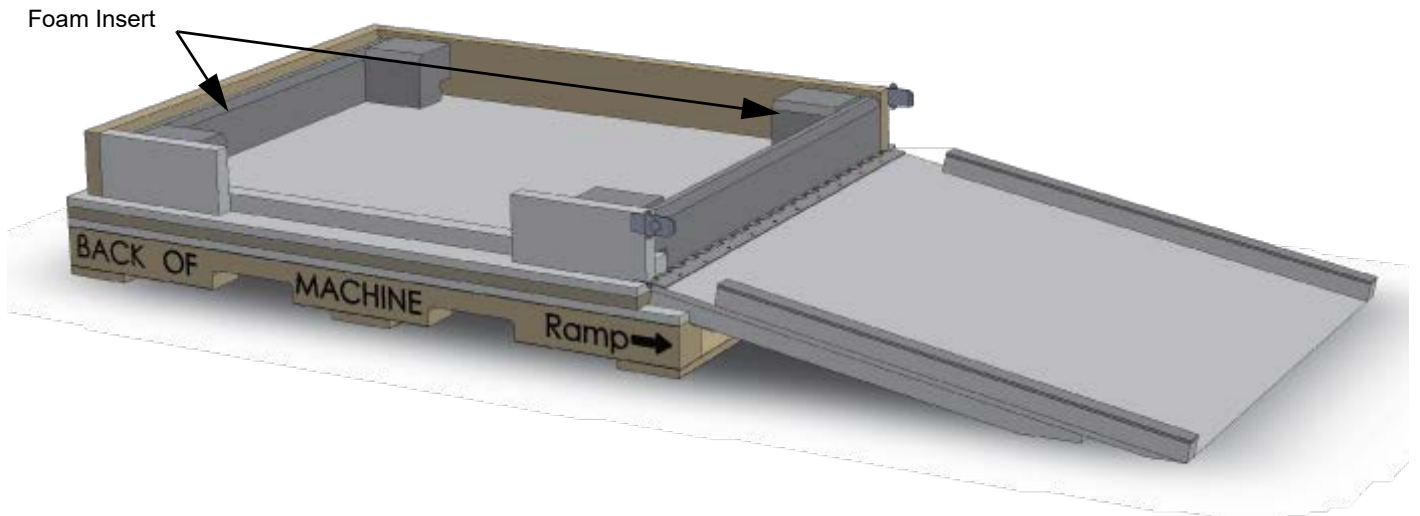

Figure 9: Ramp Down Detail



2. Remove the foam restraining insert between the ramp and the printer (Figure 9).



Caution: Use care when cutting the plastic bag to avoid scratching the printer's surfaces.

3. Remove all tape and carefully cut the plastic bag encasing the printer. Unwrap the printer by pulling the plastic bag downward.
4. Ensure that the bag is not blocking the ramp or the printer's casters. If needed, cut away the plastic bag's material from the exit side of the ramp to ensure that the printer can roll freely down the ramp.
5. Carefully roll the printer from the shipping base using the ramp.



Note: When removing the printer it is recommended that one person guide each side, while a third person support the front of the printer (to ensure that the oven door and canister bay doors do not open).

6. Inspect the printer's exterior for dents and scratches. Immediately report any damage to Stratasy and the shipping company.
7. Roll the printer into its approximate operating location.



Note: Position the printer to allow at least three feet of clearance on all sides until the installation process is complete, see "[Space Requirements](#)" on page 2. Final installation and setup must be accomplished by a qualified service representative.

REMOVAL OF REAR PANELS AND COVER

The rear service access panels and top cover can be removed in order to reduce the printer depth to an absolute minimum of 34 inches (86.36 cm). If absolute minimum printer depth is not required, proceed to “Service Connections” on page 16.

To remove the rear service access panels:

1. Using a 5 mm Allen wrench, loosen but do not remove the 4 fasteners securing the upper rear panel (see Figure 10).
2. Set the panel aside.
3. Using a 5 mm Allen wrench, loosen but do not remove the 4 fasteners securing the lower rear panel (see Figure 10).
4. Set the panel aside.

Figure 10: Rear Panel Removal



To remove the rear top cover:

1. Open the rear top cover. Disconnect the electrical wiring for the rear top cover cooling fans by pulling the connectors apart (Figure 11).
2. Using a 4 mm Allen wrench, remove the p-clamp mounting screws (2) from the upper p-clamps (Figure 11).
3. Using a 5 mm Allen wrench remove the p-clamp mounting screws (2) from the lower p-clamps (Figure 11).

Figure 11: Disconnect Fan Wiring & P-Clamps



4. Using a 4 mm Allen wrench, remove the rear top cover slider stop bolt (1) (Figure 12).

Figure 12: Disconnect Stop Bolt

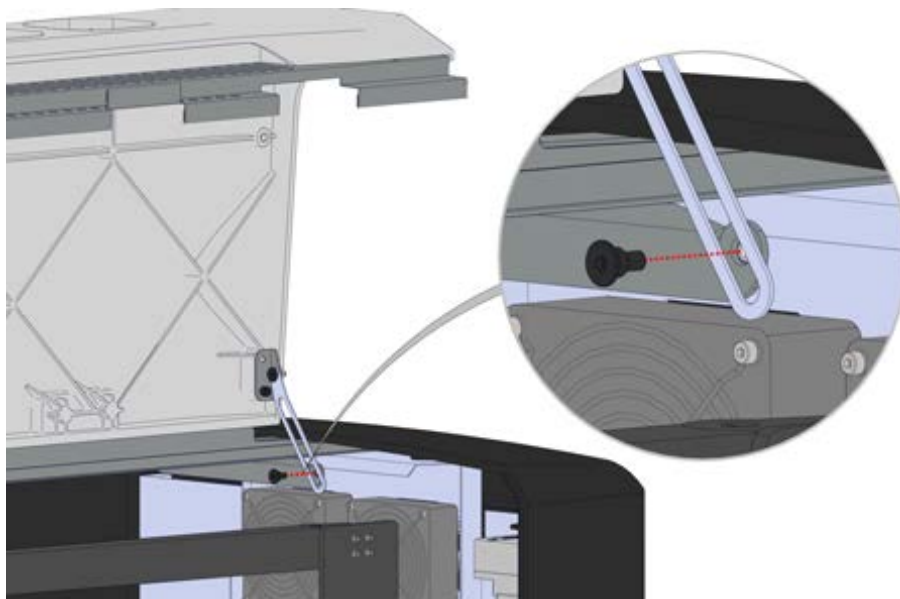

5. Close the rear top cover. Using a 5 mm Allen wrench, remove the hinge mounting screws (4) from the crossbar (Figure 13).



Note: Only remove the hinge screws from the crossbar, which secure the top cover to the printer. Do not remove the hinge screws within the top cover itself.

Figure 13: Hinge Mounting Screw Locations

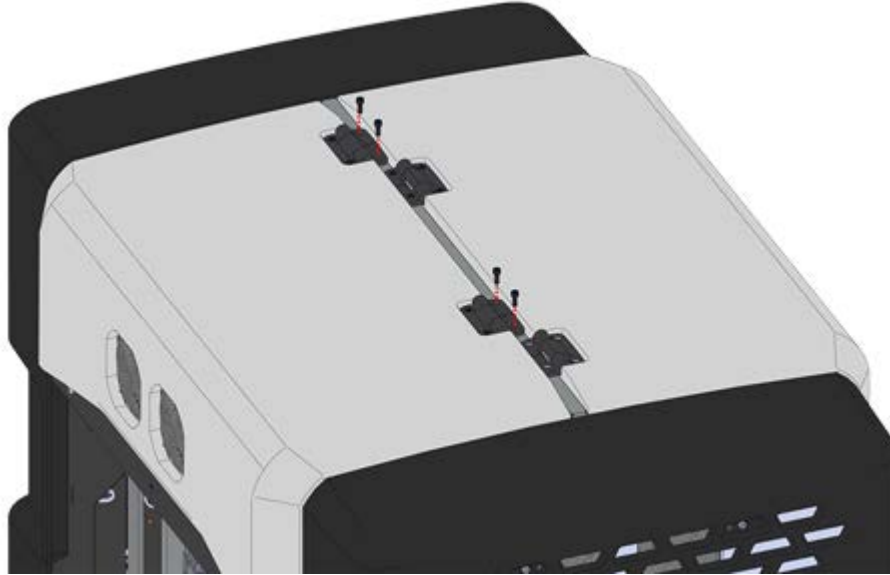

6. Lift the top cover up and away from the printer to remove, and set aside (Figure 14).

Figure 14: Rear Top Cover Removal

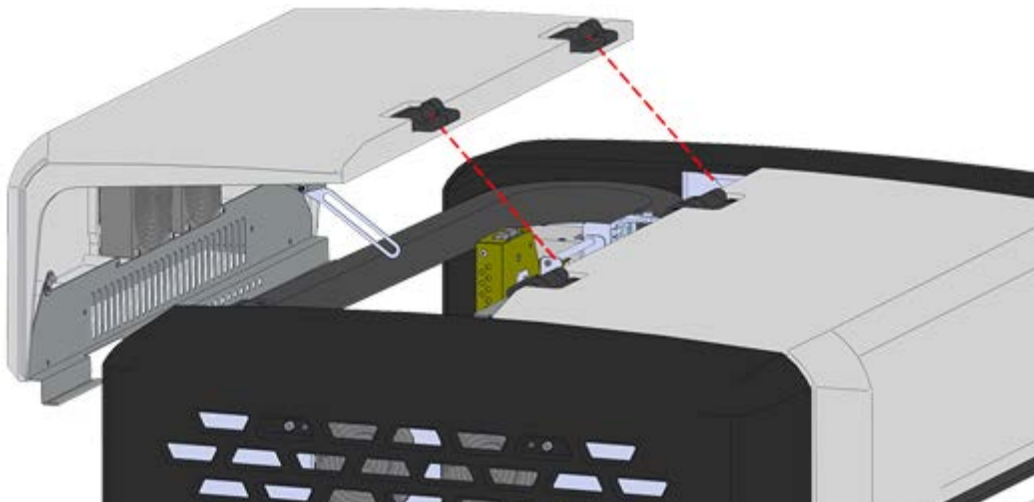

Note: The rear top cover and rear service access panels can be set aside for the installation service representative to reinstall.

SERVICE CONNECTIONS



Warning: A licensed electrician must perform all AC electrical service connections to the printer.

Consult a licensed electrician to comply with all applicable local and national electric codes.

Do not apply power to the printer until the installation service representative has verified that AC service connections have been made correctly.

After removing the lower rear panel (see [Figure 10](#)), connect the printer to the electrical service terminal block as follows ([Figure 15](#)):

- Line 1 connects to terminal block L1 (black out).
- Line 2 connects to terminal block L2 (red out).
- Line 3 connects to terminal block L3 (blue out).
- N is neutral (white out).
- Ground wire connects to the ground lug (protective earth).

Figure 15: Line Connections

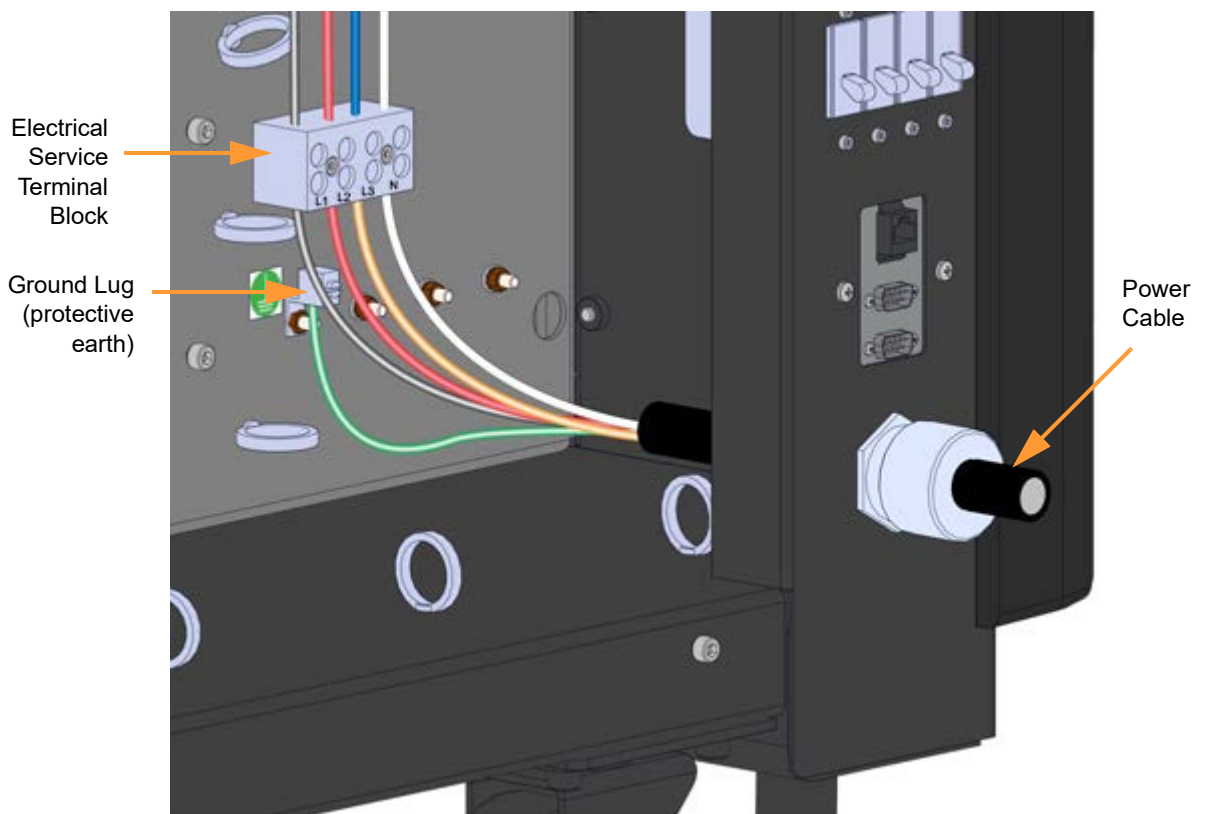

*Line connections at lower right corner of printer, as viewed from the rear.



WWW.STRATASYS.COM



c-support@stratasys.com

stratasys

THE 3D PRINTING SOLUTIONS COMPANY