

## MAIN FEATURES

Highest quality and reliability.	Wide range of standard and optional equipment.
ComAp IntelliLite AMF 25 controller.	Engine heater – ready to load just after start.
Ready to control MAINS – GENERATOR transfer switch.	Drip tray,
Configured for both manual and automatic mode (MRS + AMF).	Anticorrosion coating: frame - Zr, canopy – Zr, Al-Zn.
Wide range of remote communications options.	Brushless alternator.
Schneider NSX type GCB.	

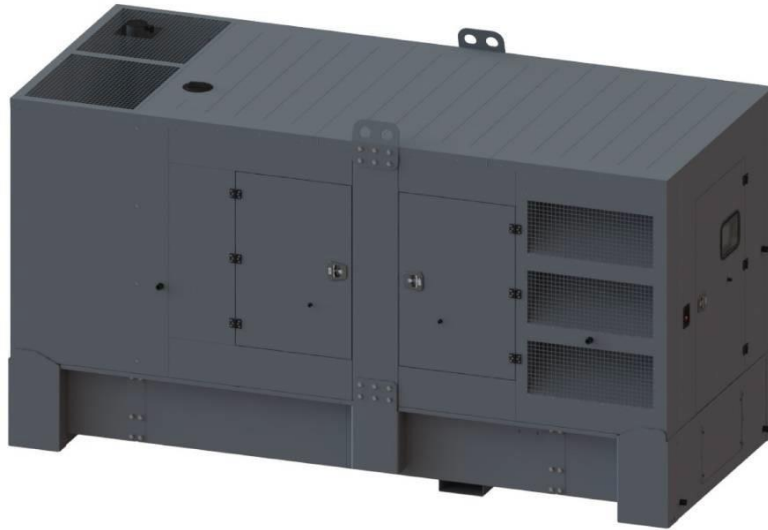

The presented image is for illustration purpose only.

## GENERAL DATA

Code	DPX-17951	<b>Nominal power P.R.P.:</b>	Prime power available in variable load application in accordance with ISO 8528, 10% overload capacity is available for a period of 1 hour within a 12-hour period of operation. Average power consumption should not exceed 70% PRP for each 24-hour period of operation.
Standby power E.S.P. [kVA] / [kW]	451,0 / 361,0	<b>Stand-by power E.S.P.:</b>	Emergency standby power rating is applicable for supplying emergency power for the duration of a utility power interruption. No overload allowed, limited to 200h of operation per year. Max mean load factor of 70% of rated power over 24-hour period of operation.
Prime power P.R.P. [kVA] / [kW]	410,0 / 328,0	<b>Remark:</b>	Ratings represent the genset performance capabilities to standard conditions specified in ISO 8528-1
Prime current P.R.P [A]	592,0	<b>Norms and directives:</b>	<ul style="list-style-type: none"> <li>• Machinery directive 2006/42/EC</li> <li>• Low voltage directive 2014/35/EC</li> <li>• EC directive 2014/30/EC</li> <li>• Noise directive 2000/14/EC</li> <li>• Emission directive 97/68/EC</li> <li>• ISO 8528-1:2018, ISO 8528-5:2018</li> <li>• ISO 8528-13:2016</li> <li>• EN 60204-1</li> </ul>
Frequency [Hz]	50		
Voltage [V]	400		
Exhaust emission	fuel optimized		
Fuel type	Diesel (EN 590)		
Fuel consumption - 50% load [l/h]	41,1		
- 75% load [l/h]	59,9		
- 100% load [l/h]	78,8		
- 110% load [l/h]	87,8		
Standard fuel tank capacity [l]	990		
Autonomy with 100% load [h]	12,6		
Engine control voltage [V]	24		
Weight without fuel [kg]	4400		
Dimensions L x W x H [mm]	4560 x 1961 x 2521		
Guaranteed noise power Lwa [dBA]	98		
Acoustic pressure Lpa (7m) [dBA]	69,1 ± 1,9		

## STANDARD CONTROLLER

Controller type: ComAp IntelliLite AMF 25

Easy to operate, intuitive graphical interface

Real time clock with battery supply

Stan-by and Prime power applications, AMF function available

Flexible event based history with up to 350 events

3 Phase generator current measurement

Generator and Mains phase voltage measurement

Active/reactive power measurement

Active and reactive energy counter

Running hours counter, multipurpose flexible timers

Battery charging alternator circuit connection

Comprehensive gen-set protections

Wide range of communication capabilities including :

- CAN and USB on board
- Internet access using Ethernet, GPRS or 4G module
- Support for Modbus and SNMP protocols

Cloud-based monitoring and control via WebSupervisor

Active SMS or e-mails (module required)

Geofencing and tracking via WebSupervisor

Operating temperature -20 + 70°C

IP65 operator interface protection

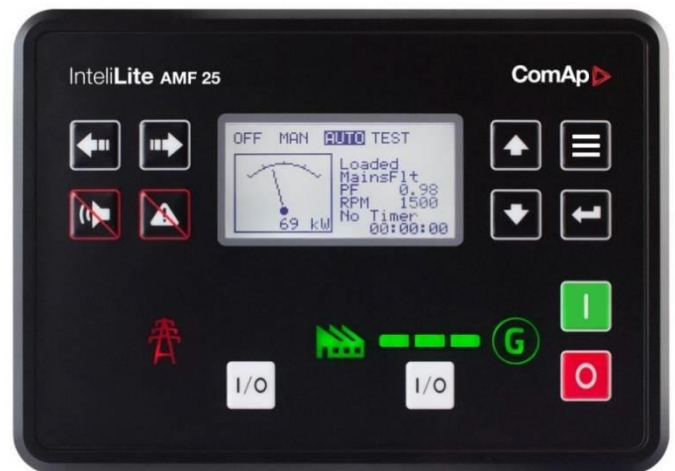

## ENGINE

Brand	Scania
Type	DC13 072A 02-12
Made in	Sweden
Engine power [kW]	355,0
Emission standard*	fuel optimized
Rotation per minute [rpm]	1500
Engine governor	electronic
Governor class**	G3
Displacement [l]	12,7
No of cylinder	6
Fuel system	unit injectors, PDE
Electrical system [V]	24
Cooling system capacity [l]	38,0
Oil pan capacity [l]	36,0
Fuel type	Diesel (EN 590)

## ALTERNATOR

Nominal Voltage [V]	400
Nominal power factor (cos phi)	0,8
Ambient temperature, altitude	40 °C, 1000m a.m.s.l
Nominal Power [kVA]	410,0
IP protection	IP 23
No of bearing	single bearing
Coupling	direct
Technology	brushless
Short circuit maintaining capacity	270% 10s
Efficiency [%]	93,3
Insulation class	H
Total harmonic content THD [%]	1,5
Reactance Xd'' [%]	15,1
Voltage regulator type	DVR, digital
Voltage measurement	3 phases
Voltage accuracy [%]	+/- 0,25
AVR supply system	auxiliary winding
AVR supply optional	PMG
Made in	EU

\* According directive 97/68/EC non road mobile machinery engine emission.

\*\* According ISO 8528-5:2018

## STANDARD EQUIPMENT

Scania DC13 072A 02-12 engine	✓
Electronic engine speed governor	✓
Oil low pressure switch	✓
Oil pressure sensor	✓
Engine high temperature switch	✓
Engine high temperature sensor	✓
Engine preheating with thermostat	✓
Engine oil Titan Cargo 15W40	✓
Fuel filter with water separator	✓
Coolant Fuchs Maintain Fricofin LL-35	✓
Coolant inlet outside of the canopy	✓
Starting batteries 2x180Ah	✓
Battery charger	✓
GCB Schneider NSX 630 3P + Mic.2.3	✓
GCB shunt release coil	✓
Controller ComAp IntelliLite AMF 25	✓
Acoustic alarm	✓
Emergency stop button	✓
Silenced canopy made with Al.-Zn.	✓
Standard color RAL 7024	✓
Fuel tank installed in drip tray	✓
Welded frame with fuel tank	✓
Fuel inlet inside, protected by canopy locked doors	✓
Fuel level measurement	✓
Exhaust compensator and silencer	✓
Engine and alternator vibro isolators	✓
Transportation brackets	✓

## OPTIONAL EQUIPMENT

Battery disconnection switch	<input type="checkbox"/>
GCB 4P Schneider NSX Micrologic 2.3	<input type="checkbox"/>
Power Lock type power output	<input type="checkbox"/>
Power socket box	<input type="checkbox"/>
Transfer switch controlled by generator controller	<input type="checkbox"/>
Transfer switch with ATS controller	<input type="checkbox"/>
GPRS communication card	<input type="checkbox"/>
Ethernet card	<input type="checkbox"/>
RS 485, RS 232 card	<input type="checkbox"/>
Remote display	<input type="checkbox"/>
Drip space level sensor	<input type="checkbox"/>
External fuel tank 1 000 – 10 000 l	<input type="checkbox"/>
3-way valve for external fuel tank connection	<input type="checkbox"/>
Fuel tank filling pump and shut-off valve	<input type="checkbox"/>
Non-standard canopy color (RAL palette)	<input type="checkbox"/>
Oil draining hand pump	<input type="checkbox"/>



## INSTALLATION GUIDELINES

Power terminal	GCB terminal
Recommended cable for up to 30m power cable way	Flexible 2x5x150 mm <sup>2</sup>
Recommended cable for do 30m generator heater supply	Flexible 3x2,5 mm <sup>2</sup>
*For additional cable connection with FOGO ATS see ATS wiring diagram	
Exhaust pipe min diameter (max. 7 m, 4 bends)	133 mm
Exhaust pipe min diameter (max. 15 m, 4 bends)	

## MAINTENANCE GUIDELINES

Fuel filters replacement	500 h / 1 year
Oil replacement	After first 100h, then every 500 h / 1 year
Oil filters replacement	After first 100h, then every 500 h / 1 year
Coolant replacement	1000 h / 2 years
Battery replacement	2 years
Electrical installation supervising	According to local requirements, at least once per year

## WARRANTY

Continuous work generators	12 months up to 1000 working hours
----------------------------	------------------------------------