

TORNOS



*The solution that evolves
with your business strategy*

Swiss DT range

The solution that evolves with your business strategy

Customized for your productivity

Maximize your productivity: The machine's base was designed for just that purpose. This fully modular machining area can accommodate any type of tool holder; drilling, milling, thread whirling or even gear hobbing are just a few examples of the Swiss DT's incredible flexibility.

5 or 6 linear axis

The Swiss DT 26 is available in 2 versions, with 5 and 6 linear axis. The version with 6 axis benefit from a counter spindle that sit on 3 axis, it means that all settings, adjustments are 100% numerical.

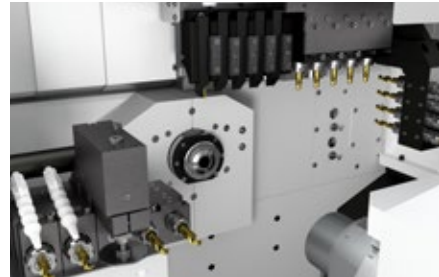

5 linear axis

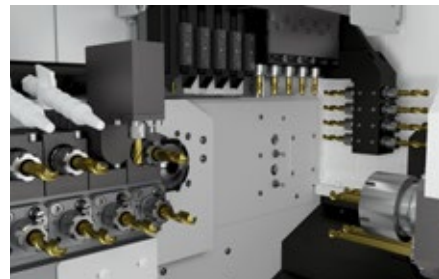

6 linear axis**

15-minute
guide-bush
conversion

Power your profitability

Gain precious seconds to outperform your competitors and tackle any material, due to the Swiss DT's extremely powerful spindles. Equipped with **ceramic bearings**, the 2 spindles benefit from the same **10.5 kW power***. Able to accelerate to 10,000 rpm in 0.3 seconds*, our spindle lets you benefit from **26 Nm (19.177 ft./lb.)*** of torque. Both spindles are liquid-cooled.

Tailored for you

Confidently conquer any machining challenge with Tornos' Swiss DT range, built for you and adapted to your needs. Get the agility to master any challenge, with the **plug-and-play B axis (option)**.

Enjoy the benefits of the most rigid machine in its class

Achieve better surface finishes and longer tool life, and get a quick return on your investment, thanks to this machine's sturdy, cast-iron base optimized by finite element analysis. The Swiss DT range can also accommodate water-based coolant.

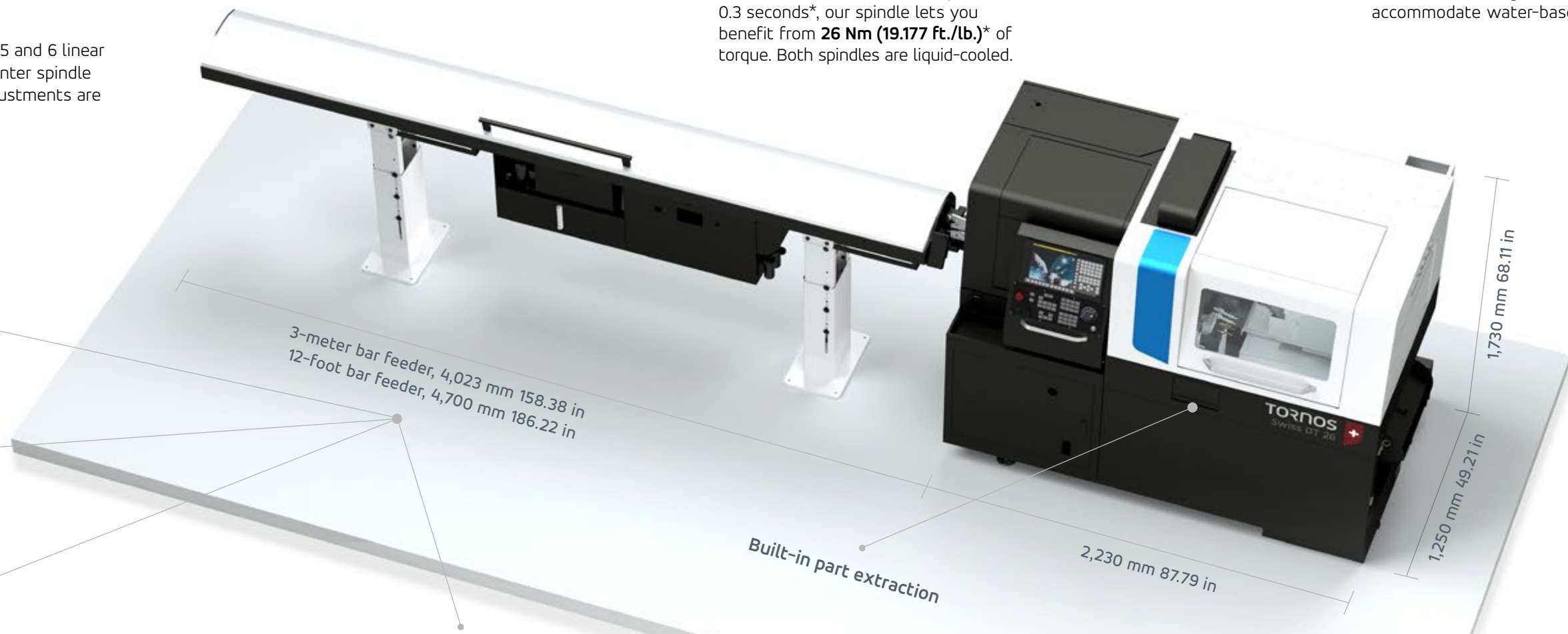

Gun drilling

Benefit from 4 tools positions for gun drilling on the Swiss DT 26/6 HP, right next to the counter-spindle



Improve and ensure self-sufficiency with Tornos' Active Chip Breaker Plus (ACB Plus) software

Improve and secure the autonomy of your process (option).



Discover more
tornos.com

* Swiss DT 26 HP

** Swiss DT 26/6 HP

Introducing the new Swiss DT range

Built on heritage since 1891

Meet your new partner: the latest-generation Swiss DT range. Exceed your own expectations, extend your competitive edge, and profit from a solution that evolves according to your business strategy.

The range consists of 7 S and HP machine configurations accommodating 13, 26, 32, and 38 mm diameter bars.

Swiss DT 13 HP
Swiss DT 13 S

Swiss DT 26 HP
Swiss DT 26 S
Swiss DT 26/6 HP

Swiss DT 32 HP

Swiss DT 38 HP



		Swiss DT 13 HP	Swiss DT 13 S	Swiss DT 26 HP	Swiss DT 26/6 HP	Swiss DT 26 S	Swiss DT 32 HP	Swiss DT 38 HP
Diameter	mm	13	13	25.4	25.4	25.4	32	38
Standard workpiece length with guide bush		210	210	210	210	210	210	210
Maximum number of tools		28	28	28	35	28	28	28
Maximum number of rotating tools		14	14	14	16	14	14	14
Plug-and-play B axis		Option	-	Option	Option	-	Option	Option
Spindle power (S1/S6)	kW	4.0 (5.0)	4.0 (5.0)	8.2 (10.5 kW)	8.2 (10.5 kW)	8.2 (10.5 kW)	8.2 (10.5 kW)	8.2 (10.5 kW)
Counter spindle power (S1/S6)	kW	4.0 (5.0)	4.0 (5.0)	8.2 (10.5 kW)	8.2 (10.5 kW)	1.5 (2.2)	8.2 (10.5 kW)	8.2 (10.5 kW)
Direct-drive guide bush		Yes	No	Yes	Yes	No	No	No

Increase your flexibility tenfold

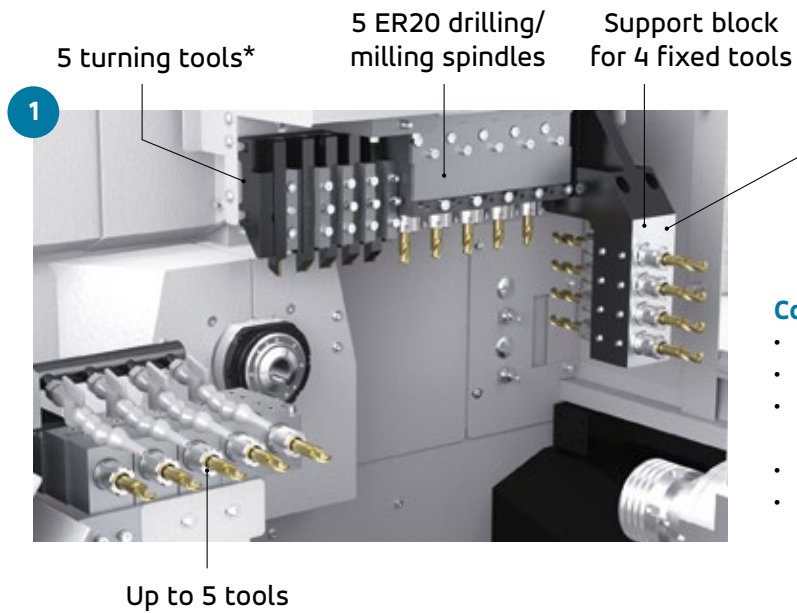

Configuration 1

- 5 turning tools (12 x 12 mm / 1/2 x 1/2 in)*
- 5 ER20 drilling/milling spindles
- Support block for 4 fixed tools or support block for 5 fixed tools
- Up to 5 tools in counter-operation
- Swiss DT 26/6 HP: Up to 8 tools in counter-operation

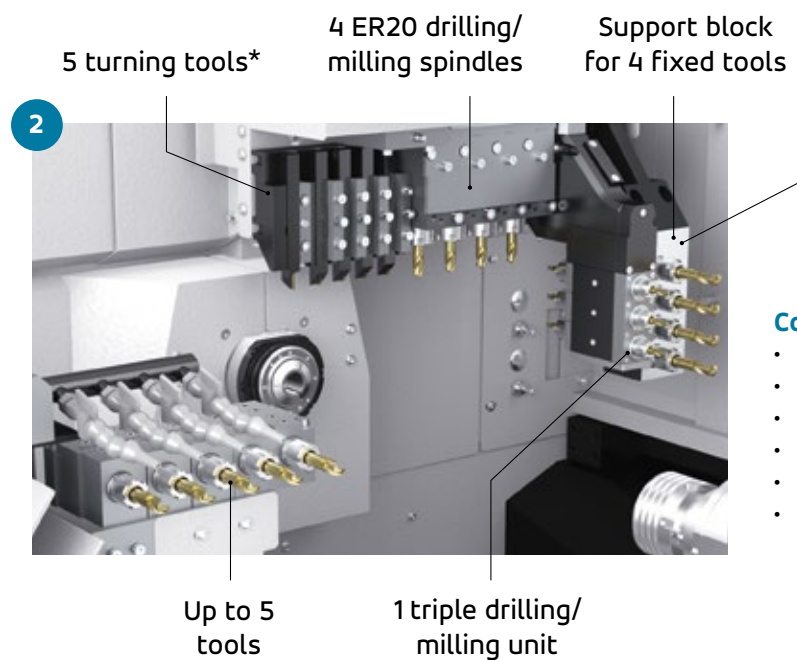

Configuration 2

- 5 turning tools (12 x 12 mm / 1/2 x 1/2 in)*
- 4 ER20 drilling/milling spindles
- 1 triple drilling/milling unit
- Support block for 4 fixed tools
- Up to 5 tools in counter-operation
- Swiss DT 26/6 HP: Up to 8 tools in counter-operation



Configuration 3

- 5 turning tools (12 x 12 mm / 1/2 x 1/2 in)*
- 6 ER20 drilling/milling spindles or 4 ER20 drilling/milling spindles and 1 high torque rotating drilling/milling spindle (ER20 + ER11)
- Up to 5 tools in counter-operation
- Swiss DT 26/6 HP: Up to 8 tools in counter-operation



High-torque rotating drilling/milling spindle

Facing difficult material?

Try out our high torque rotating drilling/milling spindle (ref. XXX-1644) with double the torque available!

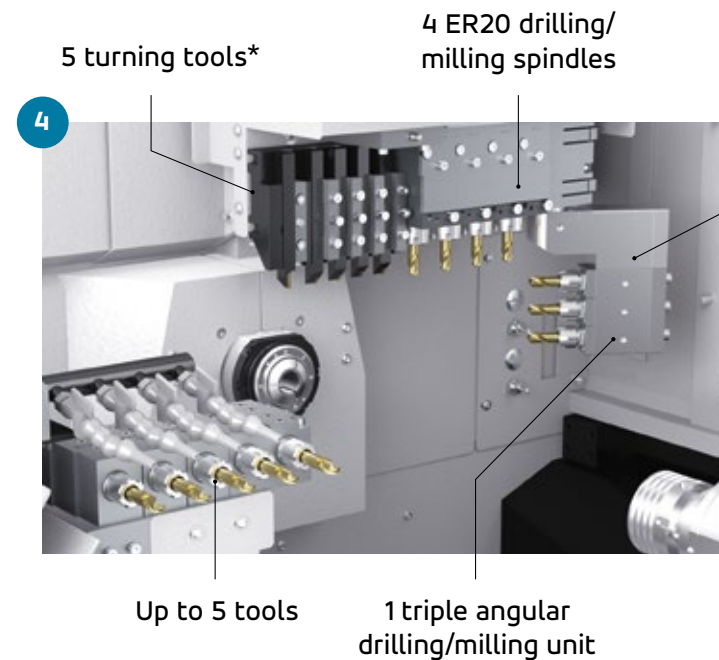

Configuration 4

- 5 turning tools (12 x 12 mm / 1/2 x 1/2 in)*
- 4 ER20 drilling/milling spindles
- 1 triple angular drilling/milling unit
- Up to 5 tools in counter-operation
- Swiss DT 26/6 HP: Up to 8 tools in counter-operation

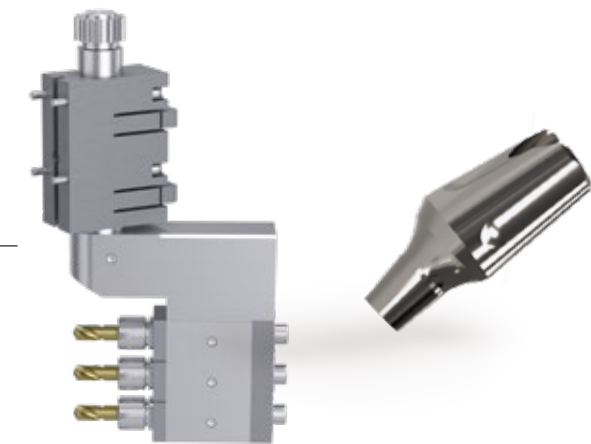



Configure your future

* Optional, and with the removal of one ER20 drilling/milling spindle, the machine can be configured with six turning tool holders 12 x 12 mm / 1/2 x 1/2 in or five turning tool holders (16 x 16 mm / 5/8 x 5/8 in).

Plug-and-play B axis

5

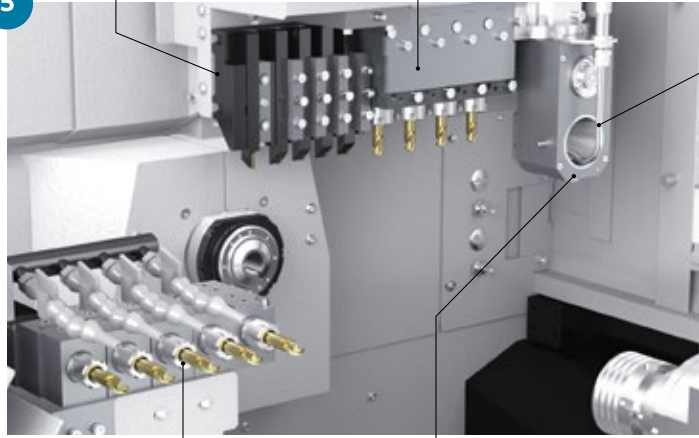
5 turning tools*
4 ER20 drilling/milling spindles



Configuration 5

- 5 turning tools (12 x 12 mm / 1/2 x 1/2 in)*
- 4 ER20 drilling/milling spindles
- Thread-whirling unit
- Up to 5 tools in counter-operation
- Swiss DT 26/6 HP: Up to 8 tools in counter-operation

Up to 5 tools
Thread-whirling unit

6

5 turning tools*
3 ER20 drilling/milling spindles



Configuration 6

- 5 turning tools (12 x 12 mm / 1/2 x 1/2 in)*
- 3 ER20 drilling/milling spindles
- Gear-hobbing unit
- Up to 5 tools in counter-operation
- Swiss DT 26/6 HP: Up to 8 tools in counter-operation

Up to 5 tools
Gear-hobbing unit

7

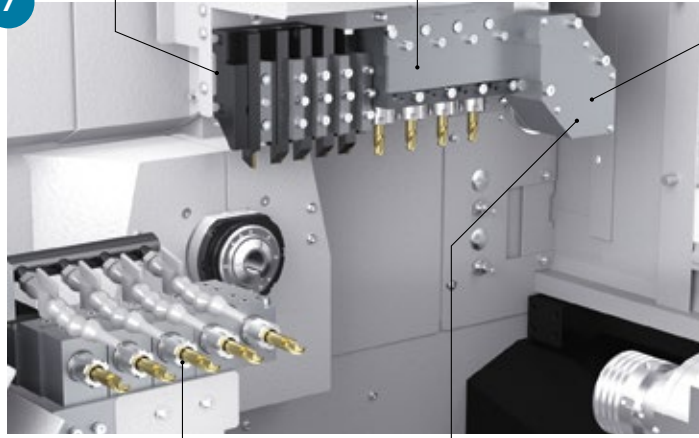
5 turning tools*
4 ER20 drilling/milling spindles

Configuration 7



- 5 turning tools (12 x 12 mm / 1/2 x 1/2 in)*
- 4 ER20 drilling/milling spindles
- Polygon milling unit
- Up to 5 tools in counter-operation
- Swiss DT 26/6 HP: Up to 8 tools in counter-operation

Up to 5 tools
Polygon milling unit

* Optional, and with the removal of one ER20 drilling/milling spindle, the machine can be configured with 6 turning tool holders 12 x 12 mm / 1/2 x 1/2 in or 5 turning tool holders (16 x 16 mm / 5/8 x 5/8 in).

8

5 turning tools*
3 ER20 drilling/milling spindles

Configuration 8



- 5 turning tools (12 x 12 mm / 1/2 x 1/2 in)
- 3 ER20 drilling/milling spindles
- Up to 5 tools in counter-operation
- Plug and play B-axis, with 2x3 ER11 drilling/milling spindles + 1 additional drilling/milling spindle for B axis, ER8 or 1 high-frequency spindle
- Swiss DT 26/6 HP: Up to 8 tools in counter-operation

Up to 5 tools
Plug-and-play B axis, with 2x3 ER11 drilling/milling spindles + 1 additional drilling/milling spindle for B axis, ER8 or 1 high-frequency spindle

NEW

9

5 turning tools*
2 ER20 drilling/milling spindles

Configuration 9

- 5 turning tools (12 x 12 mm / 1/2 x 1/2 in)
- 2 ER20 drilling/milling spindles
- Support block for 4 fixed tools
- Up to 5 tools in counter-operation
- Plug and play B-axis, with 2x3 ER11 drilling/milling spindles + 1 additional drilling/milling spindle for B axis, ER8 or 1 high-frequency spindle
- Swiss DT 26/6 HP: Up to 8 tools in counter-operation

Up to 5 tools
Plug-and-play B axis, with 2x3 ER11 drilling/milling spindles + 1 additional drilling/milling spindle for B-axis, ER8 or 1 high-frequency spindle

NEW

Plug and play B-axis

Number of rotating tool positions (main operation / counter-operation)		3 / 3 (4 / 4 option)
High-frequency spindle		1 (option)
Rotating tool speed of rotation	rpm	8,000
Rotating tool power	kW/hp	1.0 / 1.33
Max drilling diameter	mm/in	Ø5.2 / Ø0.20
Max tapping diameter		M3X0.5

Options

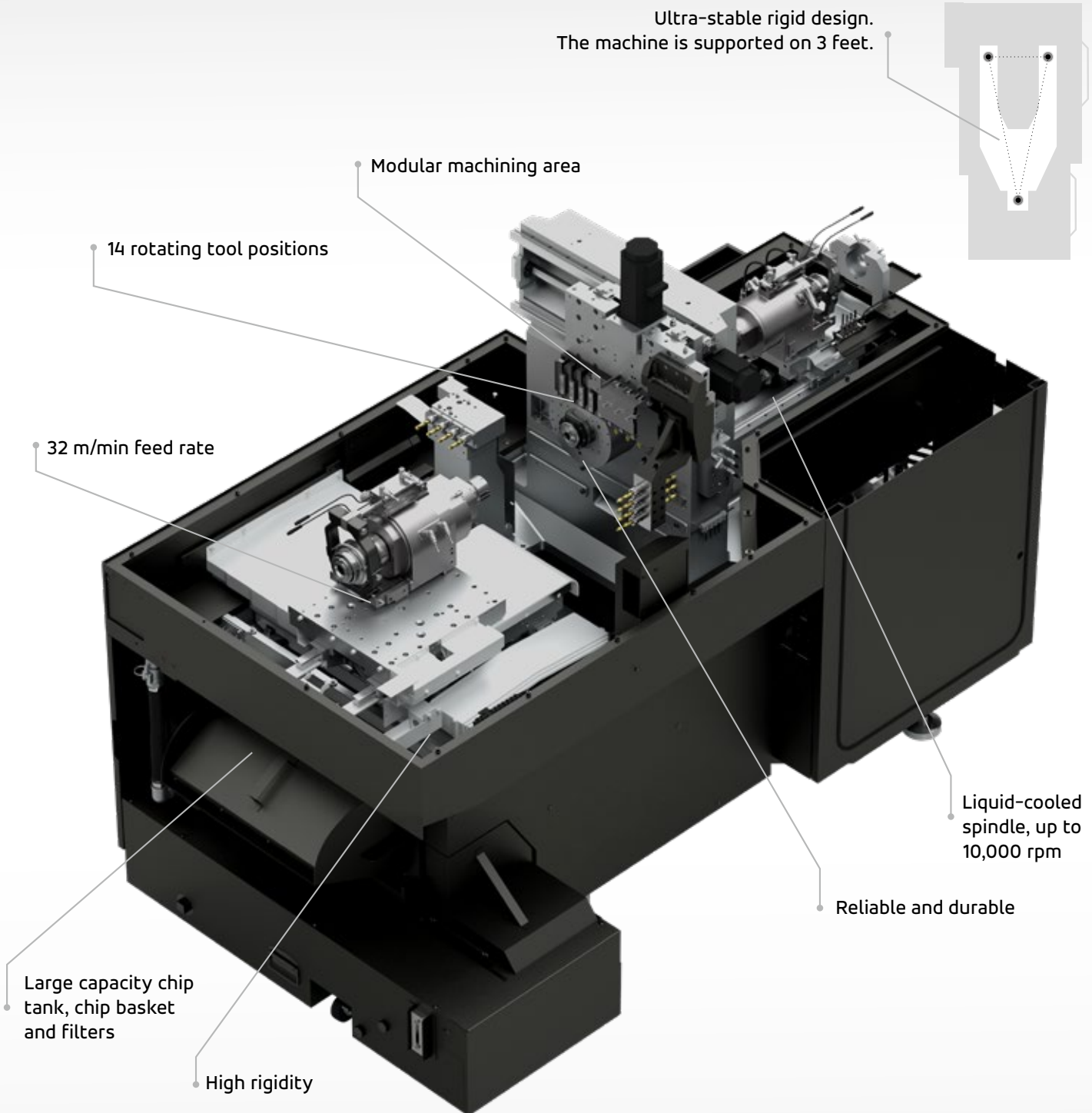

The most rigid machine base in its class



Active Chip Breaker Plus (ACB Plus)
 Extremely easy to use and can be actuated by just inserting a G code in the program. Various parameters can be used to change the oscillation amplitude and frequency to achieve a fine adjustment based on the specific workpiece requirements and thus avoid snarl chips.



B axis
 The B axis extends the Swiss DT's capabilities substantially, allowing it to tackle almost any part. This modular position can incorporate either a 4th rotating drilling station or a high frequency spindle.



High-pressure pump
 Benefit from a high-pressure-ready machine, and defeat the most difficult challenges with the Swiss DT! Whether you need a significant amount of coolant to "clean" the machining area, or more direct high-pressure coolant for thread whirling or high-pressure drilling, Tornos offers a range of pumps tailored to your requirements.



High-frequency spindles
 High-frequency spindles, with rotation speeds of up to 60,000 rpm, enable the Swiss DT to perform drilling milling and slitting as well as eccentric drilling. Spindles can be installed in main operation and counter-operation in many variants.

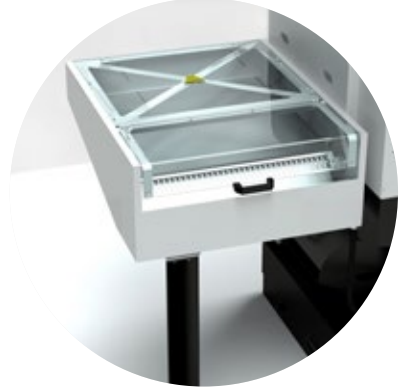

Built-in part extraction
 Long parts? Extract parts up to 500 mm, thanks to our optional long parts extraction system!



TISIS: Communicate with your machine

Programming

Able to manage up to 3 channels, the ISO editor automatically synchronizes the code between the channels. Programming your machine becomes very easy. You can see in real time the tool displacement and the cycle time of each operation. Furthermore you can easily optimize your program thanks to the patented Gant diagram provided by TISIS.

Selecting your tools

The TISIS database contains all of the tool resources; for example chisel holder plates, thread whirling tools, polygon tools or milling tools are all integrated. TISIS manages incompatibilities between the various tools and the user is guided intuitively.

Transfer

Transfer virtual programs to your bank of machines. Modify the program on the machine and transfer it again to your computer, maintaining full traceability.

Monitoring

Monitor your machine inventory in detail. See the status of the machines in the workshop and an overview of current production; the workpiece counter, remaining production time and the name and drawing of the workpiece are available at any time.



Discover the
TISIS video

Specifications

Main spindle		Swiss DT 13 HP	Swiss DT 13 S
Max bar diameter	mm/in	13 / 1/2	13 / 1/2
Standard workpiece length with guide bush	mm/in	185 / 7.28	180 / 7.08
Standard workpiece length bushless	mm/in	30 / 1.18	30 / 1.18
Spindle rotation speed	rpm	15,000	13,000 (IKO GB) / 15,000 (w.o GB)
Spindle power (S1/S6)	kW/hp	4.0 (5.0) / 5.36 (6.70)	4.0 (5.0) / 5.36 (6.70)

Main-operation			
Max number of turning tools		6 (12x12 / 1/2) / 9 (8x8 mm)	6 (12x12 / 1/2) / 9 (8x8 mm)
Number of frontal tools (main-operation / counter-operation)		4/4 (5/5 option)	4/4 (5/5 option)
Max front drilling diameter	mm/in	Ø10 / 3/8	Ø7 / 0.276
Max front tapping diameter		M6xP1.0	M6xP1.0
Cross drilling / milling tools		6 (ER20/ER11)	6 (ER20/ER11)
Max rotating tool speed	rpm	8,000	8,000
Rotating tool power	kW/hp	1 / 1.34	1 / 1.34
Max front drilling diameter rotating tools	mm/in	Ø6 / 0.23	Ø6 / 0.23
Max front tapping diameter rotating tools		M5xP0.8	M5xP0.8

Plug and play B-axis			
Number of rotating tool positions (main operation / counter-operation)		2x3 / 2X4 (option)	-
High-frequency spindle		1 (option)	-
Rotating tool speed of rotation	rpm	8,000	-
Rotating tool power	kW/hp	1.0 / 1.33	-
Max drilling diameter	mm/in	Ø5.2 / Ø0.20	-
Max tapping diameter		M3x0.5	-

Counter spindle			
Max bar diameter	mm/in	13 / 1/2	13 / 1/2
Max insertion length of workpiece into counter spindle	mm/in	100 / 3.93	80 / 3.15
Max standard length of workpiece	mm/in	120 / 4.72	90 / 3.54
Spindle rotation speed	rpm	0-15,000	0-15,000
Spindle power (S1/S6)	kW/hp	4.0 (5.0) / 5.36 (6.70)	4.0 (5.0) / 5.36 (6.70)
Max drilling diameter for the counter spindle	mm/in	Ø10 / 3/8	Ø7 / 0.276
Max tapping diameter for the counter spindle	mm/in	M6 x P1.0	M6xP1.0

Counter-operation			
Max number of tool positions		5	5
Positions for rotating tools		4	4
Max front drilling diameter for rotating tools	mm/in	Ø6 / 0.23	Ø6 / 0.23
Max tapping diameter for rotating tools	mm/in	M5xP0.8	M5xP0.8
Max rotating tool speed	rpm	7,200	10,000
Rotating tool power	kW/hp	1 / 1.34	1 / 1.34
Total number of tools		29	28

Max. rapid feed rate	m/min	32 (X1:30)	32 (X1:30)

General specifications			
Max length	mm/in	2,230 / 87.79	2,230 / 87.79
Max width	mm/in	1,250 / 49.21	1,088 / 42.83
Height	mm/in	1,730 / 68.11	1,730 / 68.11
Weight	kg	2,600	2,400
Cutting oil tank capacity	l/gal	200 / 52.8	210/55.47
Installed power	kVA	26	16

Swiss DT 26 HP	Swiss DT 26/6 HP	Swiss DT 26 S	Swiss DT 32 HP	Swiss DT 38 HP
25.4 / 1	25.4 / 1	25.4 / 1	32 / 1 1/4	38 / 1 1/2 (w.o GB) / 32 / 1 1/4 (w. GB)
225 / 8.85	225 / 8.85	220 / 8.66	250 / 9.84	250 / 9.84
55 / 2.16	55 / 2.16	55 / 2.16	80 / 3.15	80 / 3.15
0-10,000	0-10,000	0-10,000	0-8,000	0-7,000
8.2 (10.5) / 10.99 (14.08)	8.2 (10.5) / 10.99 (14.08)	8.2 (10.5) / 10.99 (14.08)	8.2 (10.5) / 10.99 (14.08)	8.2 (10.5) / 10.99 (14.08)

6 (12x12mm / 1/2) / 5 (16x16mm tools)	6 (12x12mm / 1/2) / 5 (16x16mm tools)	6 (12x12mm tools) / 5 (16x16mm tools)	5 (16x16mm tools)	5 (16x16mm tools)
4/4 (5/5 option)	4/4 (5/5 option)	4/4 (5/5 option)	4/4 (5/5 option)	4/4 (5/5 option)
Ø12 / 1/2	Ø12 / 1/2	Ø10 / 0.393	Ø12 / 0.472	Ø12 / 0.472
M10xP1.5	M10xP1.5	M10xP1.5	M10xP1.5	M10xP1.5
6 (ER20)	6 (ER20)	6 (ER20)	6 (ER20)	6 (ER20)
6,000	6,000	6,000	6,000 / 3,800 (ER25)	6,000 / 3,800 (ER25)
1 / 1.34	1 / 1.34	1 / 1.34	2.2 / 2.95	2.2 / 2.95
Ø6/Ø10 / 0.23-0.39	Ø6/Ø10 / 0.23-0.39	Ø6/Ø10 / 0.23-0.39	Ø10 / 0.39	Ø10 / 0.39
M5xP0.8/M6xP1.0	M5xP0.8/M6xP1.0	M5xP0.8/M6xP1.0	M8xP1.25	M8xP1.2

2x3 / 2X4 (option)	2x3 / 2X4 (option)	-	2x3 / 2X4 (option)	2x3 / 2X4 (option)
1 (option)	1 (option)	-	1 (option)	1 (option)
8,000	8,000	-	8,000	8,000
1.0 / 1.33	1.0 / 1.33	-	1.0 / 1.33	1.0 / 1.33
Ø5.2 / Ø0.20	Ø5.2 / Ø0.20	-	Ø5.2 / Ø0.20	Ø5.2 / Ø0.20
M3x0.5	M3x0.5	-	M3x0.5	M3x0.5

25.4 / 1	25.4 / 1	25.4 / 1	32 / 1.25	38 / 1.50
100 / 3.93	100 / 3.93	90 / 3.54	90 / 3.54	90 / 3.54
120 / 4.72	120 / 4.72	110 / 4.33	110 / 4.33	110 / 4.33
0-10,000	0-10,000	0-8,000	0-8,000	0-7,000
8.2 (10.5) / 10.99 (14.08)	8.2 (10.5) / 10.99 (14.08)	1.5 (2.2) / 2.01 (2.95)	8.2 (10.5) / 10.99 (14.08)	8.2 (10.5) / 10.99 (14.08)
Ø12 / 1/2	Ø12 / 1/2	Ø8 / 0.315	Ø12 / 0.472	Ø12 / 0.472
M10xP1.5	M10xP1.5	M6xP1.0	M10xP1.5	M10xP1.5

5	8	5	5	5
4	4	4	4	4
Ø6 / 0.23-0.39	Ø6 / 0.23-0.39	Ø6 / 0.23-0.39	Ø6 / 0.23-0.39	Ø6 / 0.23-0.39
M5xP0.8/M6xP1.0	M5xP0.8/M6xP1.0	M5xP0.8/M6xP1.0	M5xP0.8/M6xP1.0	M5xP0.8/M6xP1.0
7,200	7,500	7,500	7,500	7,500
1 / 1.34	1 / 1.34	1 / 1.34	1 / 1.34	1 / 1.34
29	35	29	28	28

	32 (X1:30)	32 (X1:30)	32 (X1:30)	32 (X1:30)	32 (X1:30)

2,230 / 87.79	2,230 / 87.79	2,230 / 87.79	2,560 / 100.79	2,560 / 100.79
1,250 / 49.21	1,250 / 49.21	1,088 / 42.83	1,285 / 50.59	1,285 / 50.59
1,730 / 68.11	1,730 / 68.11	1,730 / 68.11	2,080 / 81.89	2,080 / 81.89
2,710	2,710	2,400	2,510	2,510
200 / 52.8	200 / 52.8	210/55.47	210/55.47	210/55.47
26	26	18	20	20

We keep you turning

TORNOS LTD

Rue Industrielle 111
P.O. Box 960
2740 Moutier / Switzerland
T +41 (0)32 494 44 44

Tornos
throughout
the world



tornos.com

Complies with current European CE/EMC Safety Directives.
This document is based on information available at the time of publication. While every effort has been made to be accurate, the information contained herein does not purport to cover all details or variations in hardware and software, nor to provide for every possible contingency in connection with installation, operation and maintenance. TORNOS SA assumes no obligation of notice to holders of this document with respect to changes subsequently made. TORNOS SA makes no representation or warranty, expressed, implied, or statutory with respect to, and assumes no responsibility for the accuracy, completeness, sufficiency or usefulness of the information contained herein. No warranties of merchantability nor fitness for purpose shall apply.