

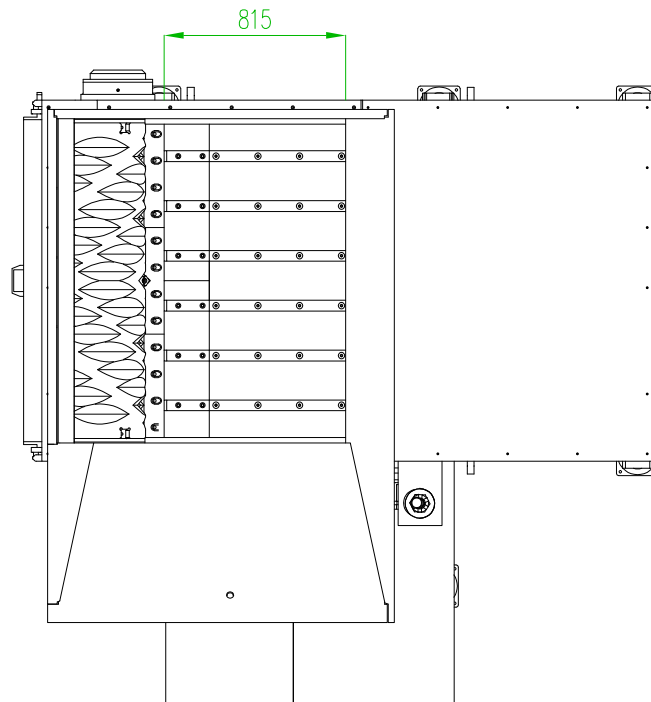

SL-V1500-26

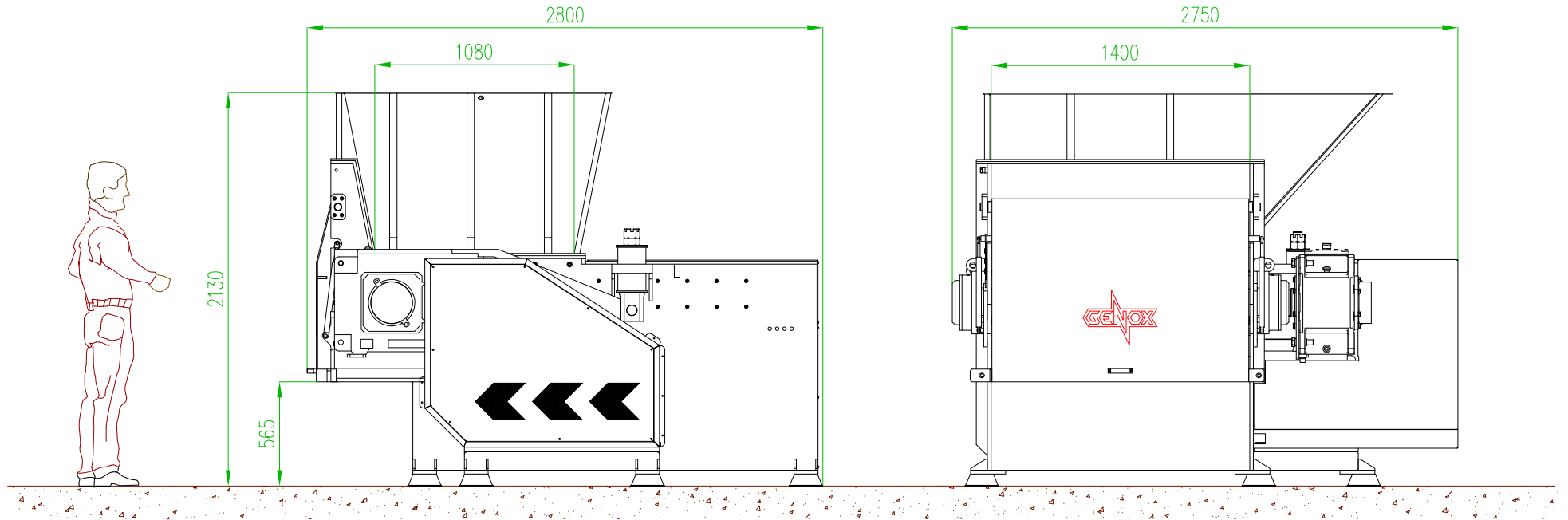

STANDARD SPECIFICATION:
 ROTOR DIAMETER: 400 MM
 ROTOR WIDTH: 1400 MM
 ROTOR BLADES: 78 PCS
 FIXED BLADES: 6 PCS
 ROTOR SPEED: 80 RPM
 DRIVE POWER: 75 KW
 HYDRAULIC POWER: 5.5 KW

STANDARD PAINT SHADES:
 MACHINE BODY (RAL 7030 - STONE GREY)
 HOPPER (RAL 7022 - UMBRA GREY)
 MAINTENANCE PARTS & MOTORS (RAL 1003 - SIGNAL YELLOW)

 <small>GENOX RECYCLING TECHNOLOGY (UK) LTD 2 CURZON ROAD, OFFERTON STOCKPORT, CHESHIRE UNITED KINGDOM SK2 5DH</small>		V1500 SINGLE SHAFT SHREDDER STANDARD LAYOUT DIMENSIONS
DATE	SCALE	SL-V1500-26
20/3/2026	N.T.S.	
DRAWN BY: J. DAKIN		