

**AVTOMATSKA ŽAGA PEGAS GONDA Automat 230 AFC**  
**KAPACITETA ŽAGE C-230 AFC**

Kapaciteta pri 0°:		Kapaciteta pri 60°:	
kvadrat	230 X 230 mm	kvadrat	95 X 95 mm
pravokotnik	280 X 150 mm	pravokotnik	130 X 90 mm
okroglo	230 mm	okroglo	135 mm
Kapaciteta pri 45°:			
kvadrat	180 X 180 mm		
pravokotnik	200 X 100 mm	Moč motorja	1,5/1,8 kW
okroglo	200 mm		
List	27 X 0,9 mm	Napajanje	380V, 50Hz, 3 faze
Dolžina lista	2.760 mm		
Hitrost lista	35-70 m/min		

**ŽAGA VSEBUJE ŠE SLEDEČO STANDARDNO OPREMO**











- ⇒ Avtomatski in polavtomatski cikel.
- ⇒ Več vrstični zaslon.
- ⇒ Servo krmiljen pomik lista v rez.
- ⇒ Pogon lista preko planetarnega reduktorja
- ⇒ Digitalni prikaz hitrosti lista
- ⇒ Fino nastavljiv pomik glave v rez.
- ⇒ Hladilna tekočina.
- ⇒ Navodila za uporabo..
- ⇒ Spisek rezervnih delov..
- ⇒ Žaga tračna Super Silencer®.

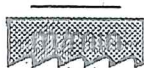

<b>TEHNIČNI PODATKI</b>	Trofazni dvobrzinski motor moči	kW	1,5 – 1,8
	Dolžina x širina x debelina lista žage	mm	2760 x 27 x 0,9
	Hitrost rezanja	m/min	35 / 70
	Največja širina vpetja v primež	mm	230
	Kot rezanja	stopinja	0 -60
	Globina stroja	mm	1700
	Širina stroja	mm	1700
	Višina stroja	mm	1750
	Teža stroja	kg	775
	Teža podstavka	kg	/
	Max hrup obratovanja	dBA	74

## TECHNICAL DATA

Purpose of the machine: AUTOMAT 230 AFC (AUTOMAT 230 AFC/ESC) is appointed for normal working conditions.

- band speed 30; 70 m/min (/ESC 18 – 110 m/min)
- electrical connection 400V, 50 Hz
- total power input of the machine 3,79/4,09 kW
- equivalent level of sound in place of cutting service  $L_{Aeq} = 79,8$  dB

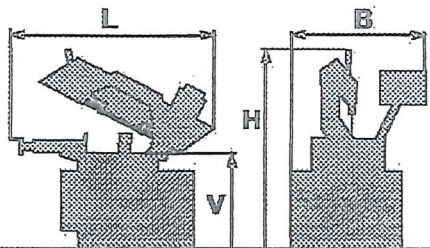
						
 0°	230	230	280x150	3~	1,5/1,8	35/70*18-110
 45°	200	180	200x100	 2760x27x0,9		
 60°	135	95	130x90			

	L 1700	 775
	B 1700	
H 1750		
V 840		

DODATNA OPREMA:

Podajalna naprava za razrez palic 5 m.