

Total heat recovery multi-purpose units with low GWP refrigerants MLE



Outdoor packaged air-water unit

MLE 40 - 240 kW



Air-water unit with total recovery heat and high seasonal efficiency and low GWP refrigerant

MLE is the new range Galletti of air-cooled packaged multifunctional heat pumps with total heat recovery for outdoor installation featuring R454B refrigerant. R454B is a next generation A2L refrigerant with a GWP of only 467, one of the lowest on the market. This GWP value ensures that the MLE range complies with the gradual reduction of greenhouse gas emissions required by the F-GAS regulation. The range consists of 12 models with cooling capacities ranging from 40 to 240 kW, available for 2+2 pipe (M version) or 4 pipe (P version) systems. The main strong point of the range is the high seasonal efficiency, aimed at definitively reducing annual energy consumption, as well as offering the possibility of satisfying the thermal load, cooling and domestic hot water production of a building with a unique solution. In order to increase the efficiency at partial loads, all MLE models are equipped with dual-circuit solutions, using up to 4 scroll compressors with IDV (intermediate discharge valve) as standard, the units are equipped with an electronic expansion valve. The use of top quality components at the cutting edge of technology in the cooling, hydraulic, and electrical systems makes MLE units state of the art in terms of efficiency, reliability, and operating limits. In fact, the ability to produce water from 5°C to 55°C, and full load operation with external air from -15°C to 45°C.

The range allows high configurability from an acoustic point of view, having a wide range of accessories designed to reduce noise emissions, and hydraulic, with the possibility of integrating up to 4 pumps on board (2 user side and 2 recovery side) and an inertial buffer tank. The advanced control, always present in the whole range, allows a continuous monitoring of the operating parameters, advanced adjustment logics, and connectivity with the most common protocols.

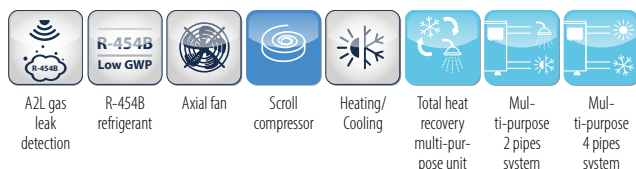

PLUS

- » Refrigerant with GWP of less than 500
- » Total heat recovery
- » High seasonal efficiency values
- » Electronic expansion valve
- » 2 cooling circuits
- » Possibility to configure low-noise versions
- » Complete access to the tax incentives (italian market)
- » Production of hot water up to 55°C
- » Full load operation up to -15°C outside air temperature

CONFIGURATOR

The models are completely configurable by selecting the version and the options. To the right is shown an example of configuration.

Version	Field	1	2	3	4	5	6	7	8	9	10	11	12	13
MLE174PS2A		A	0	0	0	E	E	0	0	0	0	0	0	1

To verify the compatibility of the options, use the selection software or the price list.

AVAILABLE VERSIONS

2 pipes systems version

MLE..MS2A

Power supply 400V-3N-50Hz + circuit breaker

MLE..MS5A

Power supply 400V-3-50Hz + circuit breaker

4 pipes systems version

MLE..PS2A

Power supply 400V-3N-50Hz + circuit breaker

MLE..PSSA

Power supply 400V-3-50Hz + circuit breaker

CONFIGURATION OPTIONS

1 Expansion valve

A Electronic

2 User side water pump

0 Absent

1 Single standard pump

2 Double std pump - OR

3 Single HP pump

4 Double HP pump - OR

A Single inverter standard pump

B Standard double inverter pump - (excludes inverter pump recovery side)

C Inverter Single HP pump

D HP double inverter pump - OR (excludes inverter pump recovery side)

3 Water buffer tank

0 Absent

R Selected recovery side

S Selected user side

4 Recovery water pump

0 Absent

1 Single standard pump

2 Double std pump - OR

3 Single HP pump

4 HP double pump - OR

A Single inverter standard pump

B Std single inverter pump - OR (excludes inverter pump user side)

C Inverter Single HP pump

D HP double inverter pump - OR (excludes inverter pump user side)

5 Air flow modulation

A with EC Fans high pressure head (not available up to size 114)

C With phase-cut (not available up to size 114)

E with EC Fans (supplied up to size 114)

6 Antifreezing kit

E Only plate exchanger (supplied user and recovery)

P Plate exchanger and pump

S For plate exchanger, pump, tank and expansion vessel.

T Plate exchanger, tank and expansion vessel

7 Acoustic insulation and attenuation

0 Absent

3 Compressor compartment acoustic insulation and sound blanket

6 Compressor soundproof insulations + Low-noise EC fans

8 Remote communication

0 Absent

2 RS485 connection port (Modbus protocol or Carel)

B BACNET IP / pCOWeb serial board

G BACNET IP / pCOWeb serial board + supervision software

L LON FTT10 serial board

9 Remote control

0 Absent

S Remote simplified control panel

X Remote control panel for advanced controller

10 Special coils / Protective treatments

0 Copper - aluminium (standard)

C Cataphoresis

I Hydrophilic

P Pre-painted fins with epoxy painting

R Copper-copper

11 Anti vibration shock mounts

0 Absent

G Made of rubber

M With spring

12 Outdoor coil trace heater and unit base

0 Absent

1 Selected

13 Onboard controller

1 Advanced

ACCESSORIES

A Outdoor finned coil heat exchanger protection filters

B Outdoor finned coil heat exchanger protection grille

C Two pairs of Victaulic joints (from size 104)

D ON/OFF status of the compressors

E Remote control for step capacity limit (advanced controller required)

F Configurable digital alarm board (advanced controller required)

G Soft starter

H Power factor capacitors

I Refrigerant sensors (standard)

L Refrigerant filter regulating kit

M 0-10V signal for external user and recovery pumps control (only if field 2 = 0 and field 4 = 0)

N Compressor isolation valves

O Night-time low-noise

Q Couple of probes for buffer tank temperature regulation (user and recovery)

R Enabling 2nd set-point / external alarm signaling via digital input

S Hot-wire electronic flow switch

T Energy metering kit

U Unit lifting pipes (up to size 94)

V Set-point modification with 4-20mA signal

OPERATING RANGE

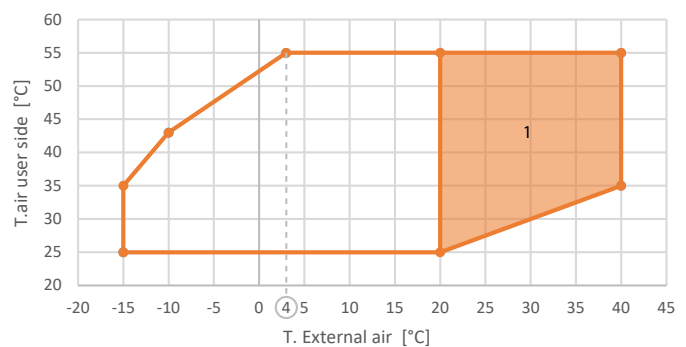
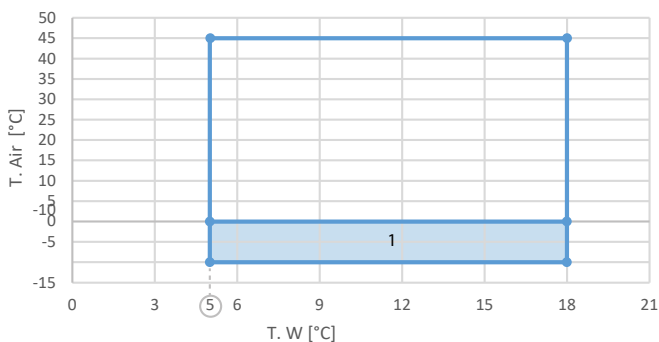

Total heat recovery multi-purpose units with low GWP refrigerants MLE

Very low GWP refrigerant

Use of R454B refrigerant with low environmental impact. R454B is a next-generation A2L refrigerant with a GWP of only 467, one of the lowest on the market. This GWP value ensures that the MLE range complies with the gradual reduction of quotas of greenhouse refrigerants in the European market required by the F-GAS regulation.

Electronic valve

It is standard on the entire range and offers greater responsiveness during transients. The electronics also manage the synergistic operation of the compressors and the valve, thereby making it possible to vary overheating and maximize efficiency at partial loads.



Scroll compressors

The scroll-type compressors designed to work with R454B, which can be sound insulated, include internal thermal protection of the windings and are installed on special anti-vibration supports. The scroll-type compressors are equipped with an IDV valve. The IDV intermediate delivery valve technology allows the compressor to avoid losses caused by overcompression and, consequently, the additional work the motor has to perform in partial-load operation, thus saving energy and improving seasonal and partial-load efficiency from 3% to 10%.



Safety procedures in case of refrigerant leakage

As a standard feature, the units are equipped with leak detection sensors near the cooling circuit. The microprocessor manages the procedures for securing and shutting down the unit in case of refrigerant leakage, also making it possible to divert the power supply of the control unit that collects the information from the leak sensors on a low-voltage emergency line. This function allows the complete disconnection of the power to the unit during maintenance operations, while leaving all the safety systems enabled.



Economy - low noise function

Based on time slots or no-voltage contact, this function makes it possible to reduce the maximum speed of fans and the number of compressors that can be activated. This operation is especially useful during the night phase, when the power required is very low, and the unit can operate at a reduced level, thus lowering the noise level during a sensitive time period.

Low noise execution

The units can be supplied in a low-noise version, with noise-canceling headsets for compressors, and additional acoustic insulation to the fridge compartment. This configuration, combined with the night attenuation function, provides a large reduction in the sound power level.

Primary heat pump management

In case of a decoupled circuit, it is possible, via remote sensor, to switch off the primary circuit's pumps, when permitted, due to low thermal load. In this manner a further reduction in pumping costs is achieved.

Power analyzer

Integrated inside the electrical panel, it includes current transformers and control unit. It allows the continuous monitoring of consumption and the main electrical quantities, then made available for any BMS system via serial port, as well as the limitation of the power absorbed when this exceeds a threshold value set by the user.

AVAILABLE VERSIONS

MLE M - 2-pipe systems

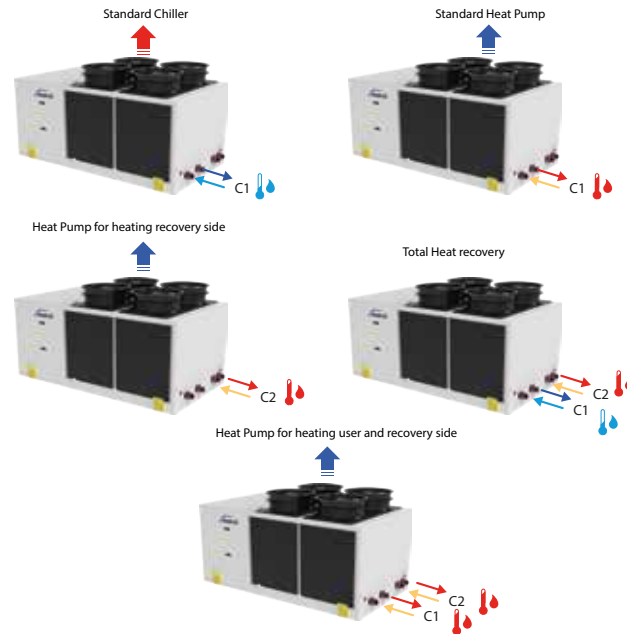

Operating modes available for an MLE M unit which interfaces with a 2-pipe system.

C1 Hydraulic circuit manages winter heating and summer air-conditioning while the C2 one is used for the production of DHW, ensuring this function 365 days per year.

In case of simultaneous production of cold (C1) and high-temperature water for domestic use (C2), the machine is able to recover all the condensation heat on the refrigerant for the production of DHW.

MLE P - 4-pipe systems

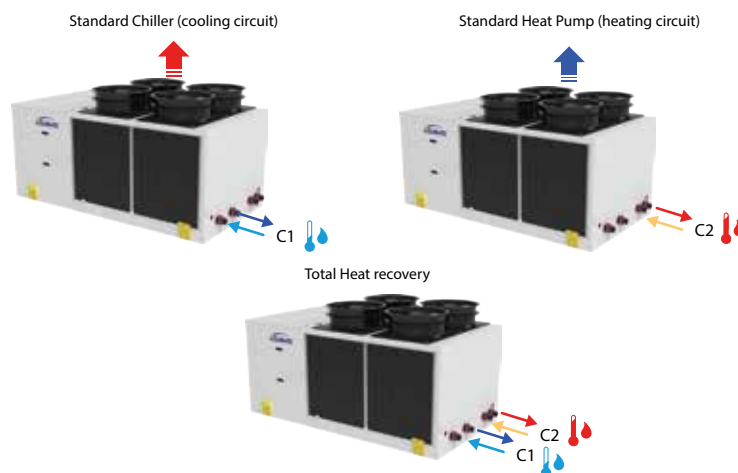

Operating modes available for an MLE P unit which interfaces with a 4-pipe air conditioning system.

In this kind of systems, it is possible to request air-conditioning and heating at the same time. For this reason, C1 and C2 hydraulic circuits respectively produce cold and hot water.

In case of simultaneous operation of C1 and C2 hydraulic circuits, the condensation heat of the cooling system is totally recovered for the production of hot water.

Total heat recovery multi-purpose units with low GWP refrigerants MLE

Operating modes of the MLE M version

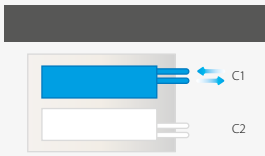

Cooling

In the "Standard Chiller" mode the MLE multifunctional unit chills water to cool a room on the user side, dissipating the condensation heat in air by means of a finned block condenser.



Heating

In the "Heat Pump" mode the MLE unit heats the water in the condenser to provide heating on the user side, absorbing the evaporative cooling capacity in air by means of a finned block heat exchanger.



Hot water production (for sanitary use-DHW)

In the "Heat Pump for hot production recovery side" mode the MLE M multipurpose unit heats the water in the recoverer, absorbing the evaporative cooling capacity in air by means of a finned block heat exchanger.

The unit MLE P in the "Heat Pump for hot production recovery side" mode heats water via the brazed plate exchanger for total heat recovery, serving the hot user side.



 simultaneous

Cooling and hot water production through total recovery

In the "Chiller + DHW" mode the MLE P multifunctional unit can produce chilled water with the simultaneous production of high-temperature hot water for sanitary use, thanks to total heat recovery.



 simultaneous

Hot water production (for example for sanitary use) simultaneously with heating

The unit MLE M in the "Heat Pump for hot production user and recovery side" mode heats water in parallel, optimally exploiting the complete independence of its thermodynamic circuits, allowing simultaneous water heating serving user site and for DHW. Capacity is equally divided between the two circuits.

The solution to the problem of defrosting

During the wintertime period, especially with temperatures ranging between -3°C and $+3^{\circ}\text{C}$, the high ambient relative humidity causes the formation of water condensation around the exchanger fins.

Since the exchanger is at a lower temperature than the outdoor air, the water in contact with it ends up hindering the heat exchange necessary for the system to work correctly.

A defrost cycle is a temporary reversal of the thermodynamic cycle which switches the unit into the summer mode and melts the ice present between fins.

This phase is obviously problematic, since the cooling cycle warms up the exchanger by drawing heat from the room that was previously being heated. The circuit that is defrosting will draw heat on the user side (that is, not on the DHW side) if the unit is MLE M, and will heat on the hot water user side if the unit is MLE P.

Separate defrosting

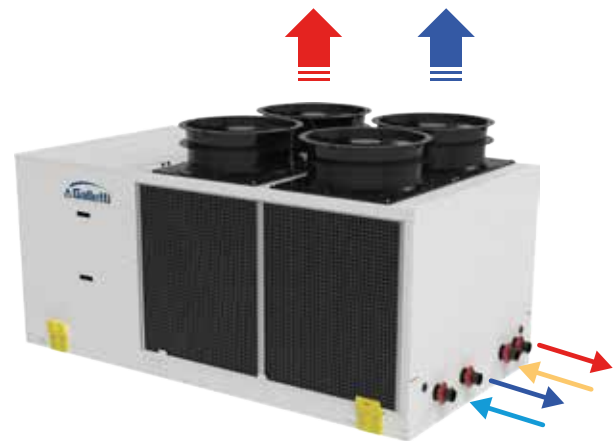

The MLE unit reduces this problem with the following technical innovations:

- The two thermodynamic circuits in the MLE P M and MLE P P are completely independent and while one defrosts, the other circuit is able to ensure continuity in the unit's operation, with practically no thermal discomfort for the user.
- The software which manages the defrost cycle minimizes the time it takes to complete it and only acts when it is really necessary. The fans are pushed to their maximum capacity at just the right time, that is, when the ice is no longer stuck to the fins, and mechanically ejects it from the heat exchanger.

EVROPROM — 200+ new and used chillers in stock in Europe
www.evroprom.com | evroprom.sales@evroprom.com

RATED TECHNICAL DATA MLE P

MLE			41	51	61	84	94	104
Power supply		V-ph-Hz	400-3N-50					
Cooling mode operation								
Cooling capacity	(1)(E)	kW	40,0	50,9	57,9	80,0	88,9	101
Total power input	(1)(E)	kW	14,0	18,6	20,8	28,5	33,6	37,3
EER	(1)(E)		2,85	2,74	2,78	2,80	2,65	2,71
Water flow	(1)	l/h	6879	8754	9959	13760	15311	17382
Water pressure drop	(1)(E)	kPa	16	25	31	32	39	31
Available pressure head - LP pumps	(1)	kPa	170	152	140	124	103	120
Available pressure head - HP pumps	(1)	kPa	204	187	176	192	179	178
Cooling and heating mode in total heat recovery								
Cooling capacity	(2)(E)	kW	38,9	51,5	58,3	75,3	88,5	101
Heating capacity	(2)(E)	kW	52,4	69,2	78,9	103	121	137
Total power input	(2)(E)	kW	12,4	16,2	18,6	25,5	29,4	32,7
TER	(2)(E)		7,35	7,45	7,36	7,00	7,12	7,28
Available pressure head LP pumps user side		kPa	170	154	143	117	103	121
Available pressure head HP pumps user side		kPa	205	189	178	188	179	180
Available pressure head LP pump total recovery side		kPa	166	147	132	112	89	105
Available pressure head HP pump total recovery side		kPa	201	182	167	185	170	163
Heating mode operation								
Heating capacity	(3)(E)	kW	45,2	58,1	67,7	89,4	103	119
Total power input	(3)(E)	kW	13,9	17,4	19,9	27,6	31,3	35,2
COP	(3)(E)		3,26	3,33	3,41	3,24	3,28	3,39
SCOP	(4)		3,54	3,61	3,62	3,70	3,75	3,75
Water flow	(3)	l/h	7842	10083	11743	15493	17788	20674
Water pressure drop	(3)(E)	kPa	18	29	38	36	46	43
Available pressure head - LP pumps	(3)	kPa	164	142	128	109	82	104
Available pressure head - HP pumps	(3)	kPa	198	177	163	183	166	162
General data								
Maximum current absorption		A	40,0	50,0	54,0	74,0	86,0	98,0
Start up current		A	98	142	147	98	142	142
Startup current with soft starter		A	69	99	103	69	99	99
Compressors / circuits			2/2	2/2	2/2	4/2	4/2	4/2
Expansion vessel volume		dm ³	8	8	8	8	8	12
Buffer tank volume		dm ³	125	125	125	200	200	315
Sound power level	(5)(E)	dB(A)	83	83	83	84	85	86
Weight without options		kg	690	705	715	960	985	1350
Maximum transport weight		kg	782	798	809	1092	1121	1458

(1) Outdoor air temperature 35°C, water temperature 12°C / 7°C (EN14511:2022)

(2) Cooling water temperature 7°C, water flow rate same as in cooling mode; Recovery water temperature 45°C, water flow rate same as in heating mode

(3) Outdoor air temperature dry bulb 7°C / wet bulb 6°C, water temperature 40°C / 45°C (EN14511:2022)

(4) η efficiency values for heating and cooling are respectively calculated by the following formulas: $[\eta = SCOP / 2,5 - F(1) - F(2)]$ e $[\eta = SEER / 2,5 - F(1) - F(2)]$. For further information, please refer to the technical document "ErP 2009/125/EC DIRECTIVE" in the catalogue introducing pages, or to the EN14825:2022 regulation. Low temperature conditions.

(5) Sound power level measured according to ISO 9614

(E) EUROVENT certified data

Total heat recovery multi-purpose units with low GWP refrigerants MLE

RATED TECHNICAL DATA MLE P

MLE			114	144	154	174	204	244
Power supply		V-ph-Hz	400-3N-50					
Cooling mode operation								
Cooling capacity	(1)(E)	kW	119	137	150	170	200	234
Total power input	(1)(E)	kW	42,7	48,4	55,0	65,4	75,8	92,0
EER	(1)(E)		2,79	2,83	2,73	2,60	2,64	2,54
Water flow	(1)	l/h	20491	23570	25823	29266	34424	40218
Water pressure drop	(1)(E)	kPa	41	28	33	41	31	41
Available pressure head - LP pumps	(1)	kPa	107	184	168	141	148	113
Available pressure head - HP pumps	(1)	kPa	166	307	290	263	197	163
Cooling and heating mode in total heat recovery								
Cooling capacity	(2)(E)	kW	115	134	150	174	202	244
Heating capacity	(2)(E)	kW	156	180	201	234	271	326
Total power input	(2)(E)	kW	37,6	41,9	46,5	55,4	63,0	76,4
TER	(2)(E)		7,21	7,51	7,53	7,37	7,51	7,45
Available pressure head LP pumps user side		kPa	102	183	168	142	153	123
Available pressure head HP pumps user side		kPa	161	306	290	265	202	173
Available pressure head LP pump total recovery side		kPa	91	170	153	121	142	103
Available pressure head HP pump total recovery side		kPa	149	292	274	242	191	153
Heating mode operation								
Heating capacity	(3)(E)	kW	134	154	168	193	225	268
Total power input	(3)(E)	kW	39,8	47,3	52,1	60,8	71,9	84,2
COP	(3)(E)		3,36	3,26	3,22	3,17	3,13	3,18
SCOP	(4)		3,80	3,70	3,71	3,70	3,60	3,65
Water flow	(3)	l/h	23166	26732	29153	33439	39120	46430
Water pressure drop	(3)(E)	kPa	53	36	42	54	35	48
Available pressure head - LP pumps	(3)	kPa	87	163	142	105	129	84
Available pressure head - HP pumps	(3)	kPa	145	285	263	227	178	134
General data								
Maximum current absorption		A	106	115	127	145	165	193
Start up current		A	147	158	197	215	215	260
Startup current with soft starter		A	103	111	138	150	150	182
Compressors / circuits			4/2					
Expansion vessel volume		dm ³	12	24	24	24	24	24
Buffer tank volume		dm ³	315	600	600	600	600	600
Sound power level	(5)(E)	dB(A)	86	85	85	87	89	89
Weight without options		kg	1355	1795	1810	1895	2320	2320
Maximum transport weight		kg	1464	1988	2000	2090	2560	2562

(1) Outdoor air temperature 35°C, water temperature 12°C / 7°C (EN14511:2022)

(2) Cooling water temperature 7°C, water flow rate same as in cooling mode; Recovery water temperature 45°C, water flow rate same as in heating mode

(3) Outdoor air temperature dry bulb 7°C / wet bulb 6°C, water temperature 40°C / 45°C (EN14511:2022)

(4) η efficiency values for heating and cooling are respectively calculated by the following formulas: $[\eta = SCOP / 2,5 - F(1) - F(2)]$ e $[\eta = SEER / 2,5 - F(1) - F(2)]$. For further information, please refer to the technical document "ErP 2009/125/EC DIRECTIVE" in the catalogue introducing pages, or to the EN14825:2022 regulation. Low temperature conditions.

(5) Sound power level measured according to ISO 9614

(E) EUROVENT certified data

RATED TECHNICAL DATA MLE M

MLE			41	51	61	84	94	104
Power supply		V-ph-Hz	400-3N-50					
Cooling mode operation								
Cooling capacity	(1)(E)	kW	40,0	50,9	57,9	80,0	88,9	101
Total power input	(1)(E)	kW	14,0	18,6	20,8	28,5	33,6	37,3
EER	(1)(E)		2,85	2,74	2,78	2,80	2,65	2,71
Water flow	(1)	l/h	6879	8754	9959	13760	15311	17382
Water pressure drop	(1)(E)	kPa	16	25	31	32	39	31
Available pressure head - LP pumps	(1)	kPa	170	152	140	124	103	120
Available pressure head - HP pumps	(1)	kPa	204	187	176	192	179	178
Cooling and heating mode in total heat recovery								
Cooling capacity	(2)(E)	kW	38,9	51,5	58,3	75,3	88,5	101
Heating capacity	(2)(E)	kW	52,4	69,2	78,9	103	121	137
Total power input	(2)(E)	kW	12,4	16,2	18,6	25,5	29,4	32,7
TER	(2)(E)		7,35	7,45	7,36	7,00	7,12	7,28
Available pressure head LP pumps user side		kPa	170	154	143	117	103	121
Available pressure head HP pumps user side		kPa	205	189	178	188	179	180
Available pressure head LP pump total recovery side		kPa	166	147	132	112	89	105
Available pressure head HP pump total recovery side		kPa	201	182	167	185	170	163
Heating mode operation								
Heating capacity	(3)(E)	kW	44,1	56,8	66,2	87,3	100	116
Total power input	(3)(E)	kW	14,8	18,5	21,1	29,4	33,3	37,4
COP	(3)(E)		2,98	3,07	3,14	2,97	3,01	3,11
SCOP	(4)		3,54	3,61	3,62	3,70	3,75	3,75
Water flow	(3)	l/h	7658	9853	11471	15140	17345	20177
Water pressure drop	(3)(E)	kPa	18	28	36	35	44	41
Available pressure head - LP pumps	(3)	kPa	166	144	131	112	88	107
Available pressure head - HP pumps	(3)	kPa	200	179	166	185	169	165
General data								
Maximum current absorption		A	40,0	50,0	54,0	74,0	86,0	98,0
Start up current		A	98	142	147	98	142	142
Startup current with soft starter		A	69	99	103	69	99	99
Compressors / circuits			2/2	2/2	2/2	4/2	4/2	4/2
Expansion vessel volume		dm ³	8	8	8	8	8	12
Buffer tank volume		dm ³	125	125	125	200	200	315
Sound power level	(5)(E)	dB(A)	83	83	83	84	85	86
Weight without options		kg	690	705	715	960	985	1350
Maximum transport weight		kg	782	798	809	1092	1121	1458

(1) Outdoor air temperature 35°C, water temperature 12°C / 7°C (EN14511:2022)

(2) Cooling water temperature 7°C, water flow rate same as in cooling mode; Recovery water temperature 45°C, water flow rate same as in heating mode

(3) Outdoor air temperature dry bulb 7°C / wet bulb 6°C, water temperature 40°C / 45°C (EN14511:2022)

(4) η efficiency values for heating and cooling are respectively calculated by the following formulas: $[\eta = SCOP / 2,5 - F(1) - F(2)]$ e $[\eta = SEER / 2,5 - F(1) - F(2)]$. For further information, please refer to the technical document "ErP 2009/125/EC DIRECTIVE" in the catalogue introducing pages, or to the EN14825:2022 regulation. Low temperature conditions.

(5) Sound power level measured according to ISO 9614

(E) EUROVENT certified data

Total heat recovery multi-purpose units with low GWP refrigerants MLE

RATED TECHNICAL DATA MLE M

MLE			114	144	154	174	204	244
Power supply		V-ph-Hz	400-3N-50					
Cooling mode operation								
Cooling capacity	(1)(E)	kW	119	137	150	170	200	234
Total power input	(1)(E)	kW	42,7	48,4	55,0	65,4	75,8	92,0
EER	(1)(E)		2,79	2,83	2,73	2,60	2,64	2,54
Water flow	(1)	l/h	20491	23570	25823	29266	34424	40218
Water pressure drop	(1)(E)	kPa	41	28	33	41	31	41
Available pressure head - LP pumps	(1)	kPa	107	184	168	141	148	113
Available pressure head - HP pumps	(1)	kPa	166	307	290	263	197	163
Cooling and heating mode in total heat recovery								
Cooling capacity	(2)(E)	kW	115	134	150	174	202	244
Heating capacity	(2)(E)	kW	156	180	201	234	271	326
Total power input	(2)(E)	kW	37,6	41,9	46,5	55,4	63,0	76,4
TER	(2)(E)		7,21	7,51	7,53	7,37	7,51	7,45
Available pressure head LP pumps user side		kPa	102	183	168	142	153	123
Available pressure head HP pumps user side		kPa	161	306	290	265	202	173
Available pressure head LP pump total recovery side		kPa	91	170	153	121	142	103
Available pressure head HP pump total recovery side		kPa	149	292	274	242	191	153
Heating mode operation								
Heating capacity	(3)(E)	kW	130	150	164	189	221	262
Total power input	(3)(E)	kW	42,4	50,2	55,4	64,7	76,5	89,8
COP	(3)(E)		3,08	2,99	2,96	2,91	2,89	2,92
SCOP	(4)		3,80	3,70	3,71	3,70	3,60	3,65
Water flow	(3)	l/h	22603	26052	28405	32719	38351	45543
Water pressure drop	(3)(E)	kPa	50	34	40	52	34	47
Available pressure head - LP pumps	(3)	kPa	91	168	147	112	133	90
Available pressure head - HP pumps	(3)	kPa	149	289	268	233	182	139
General data								
Maximum current absorption		A	106	115	127	145	165	193
Start up current		A	147	158	197	215	215	260
Startup current with soft starter		A	103	111	138	150	150	182
Compressors / circuits			4/2					
Expansion vessel volume		dm ³	12	24	24	24	24	24
Buffer tank volume		dm ³	315	600	600	600	600	600
Sound power level	(5)(E)	dB(A)	86	85	85	87	89	89
Weight without options		kg	1355	1795	1810	1895	2320	2320
Maximum transport weight		kg	1464	1988	2000	2090	2560	2562

(1) Outdoor air temperature 35°C, water temperature 12°C / 7°C (EN14511:2022)

(2) Cooling water temperature 7°C, water flow rate same as in cooling mode; Recovery water temperature 45°C, water flow rate same as in heating mode

(3) Outdoor air temperature dry bulb 7°C / wet bulb 6°C, water temperature 40°C / 45°C (EN14511:2022)

(4) η efficiency values for heating and cooling are respectively calculated by the following formulas: $[\eta = SCOP / 2,5 - F(1) - F(2)]$ e $[\eta = SEER / 2,5 - F(1) - F(2)]$. For further information, please refer to the technical document "ErP 2009/125/EC DIRECTIVE" in the catalogue introducing pages, or to the EN14825:2022 regulation. Low temperature conditions.

(5) Sound power level measured according to ISO 9614

(E) EUROVENT certified data

DIMENSIONAL DRAWINGS

MLE 41 - 51 - 61

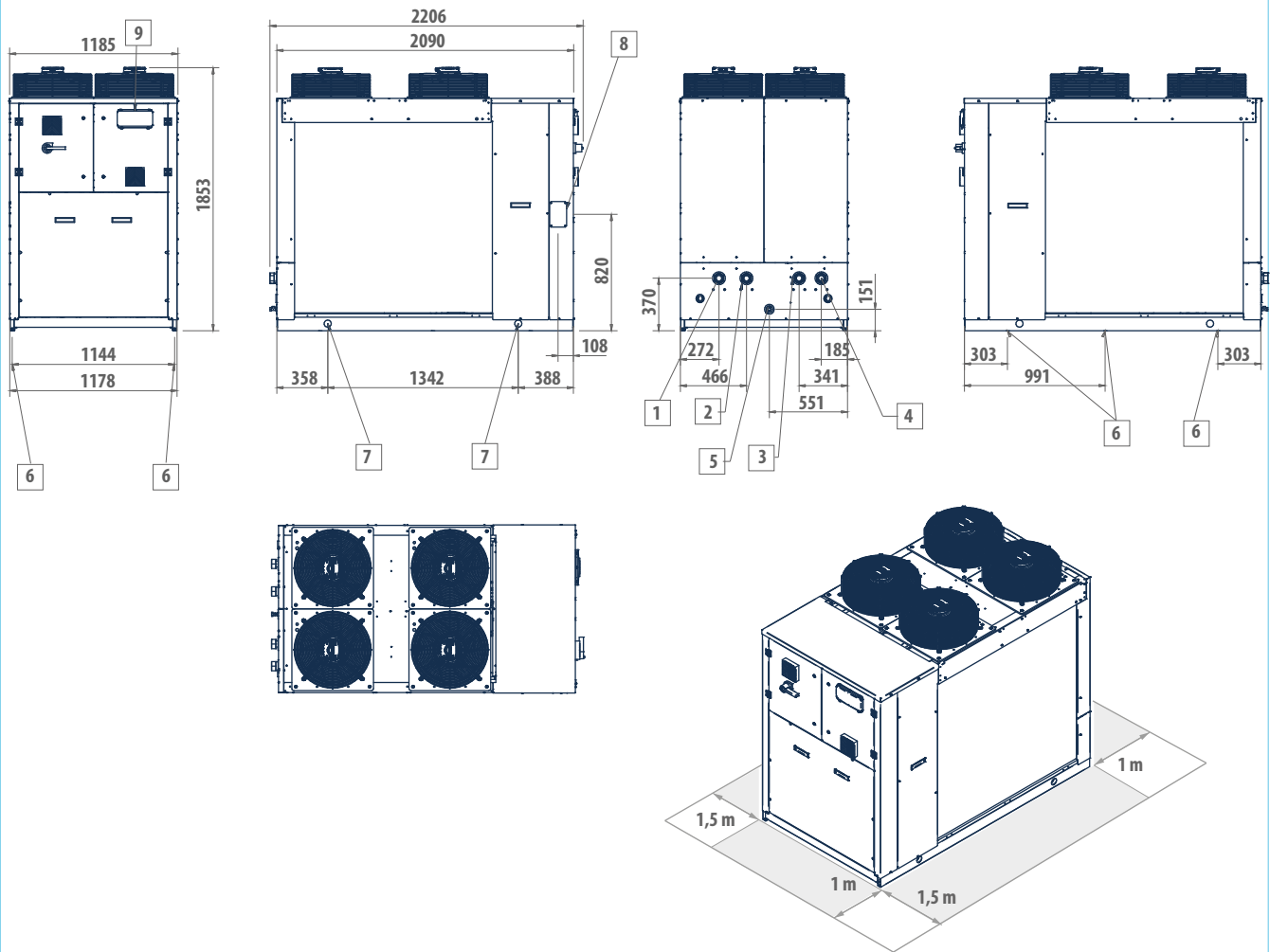

LEGEND

1	Water inlet on user side 2" F
2	Water outlet user 2" F
3	Heat recovery hot water inlet 2" F
4	Recovery hot water outlet recovery 2" F
5	Water drainage tank 1/2" F
6	Vibration dumpers
7	Lifting points
8	Power supply input
9	User interface

Total heat recovery multi-purpose units with low GWP refrigerant - MLE

Total heat recovery multi-purpose units with low GWP refrigerants MLE

DIMENSIONAL DRAWINGS

MLE 84 - 94

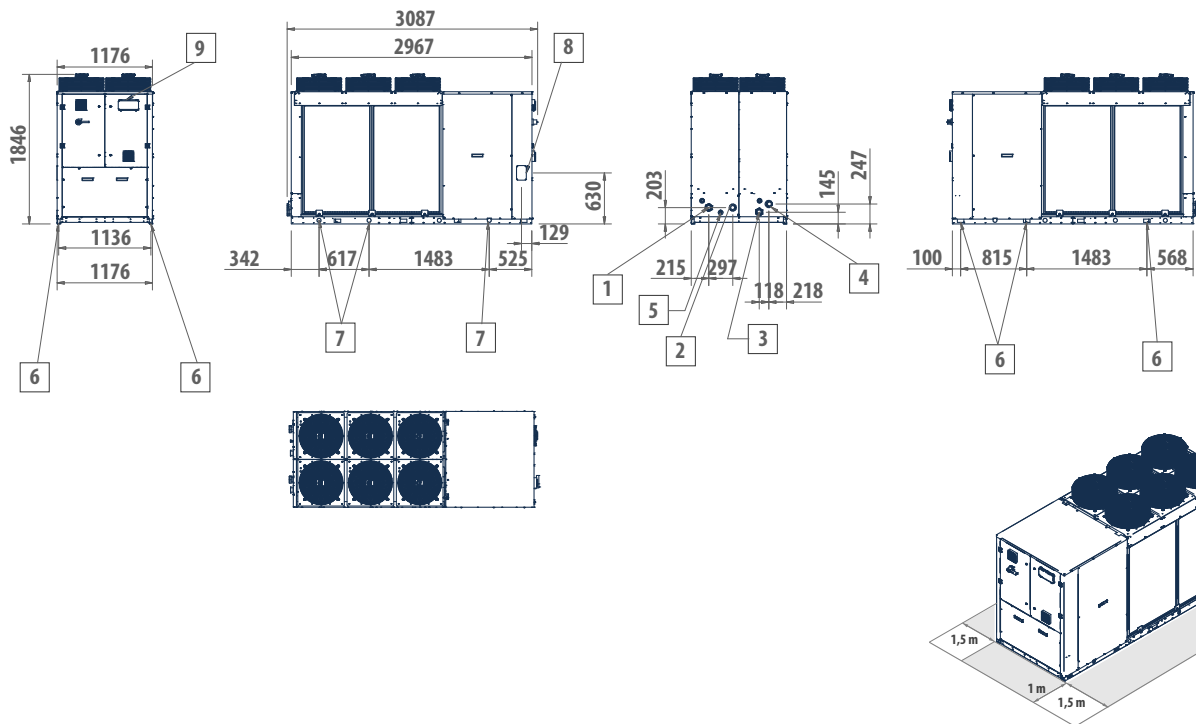

LEGEND

1	Water inlet on user side 2" 1/2 F
2	Water outlet user 2" 1/2 F
3	Heat recovery hot water inlet 2" 1/2 F
4	Recovery hot water outlet recovery 2" 1/2 F
5	Water drainage tank 1/2" F
6	Vibration dumpers
7	Lifting points
8	Power supply input
9	User interface

DIMENSIONAL DRAWINGS

MLE 104 - 114

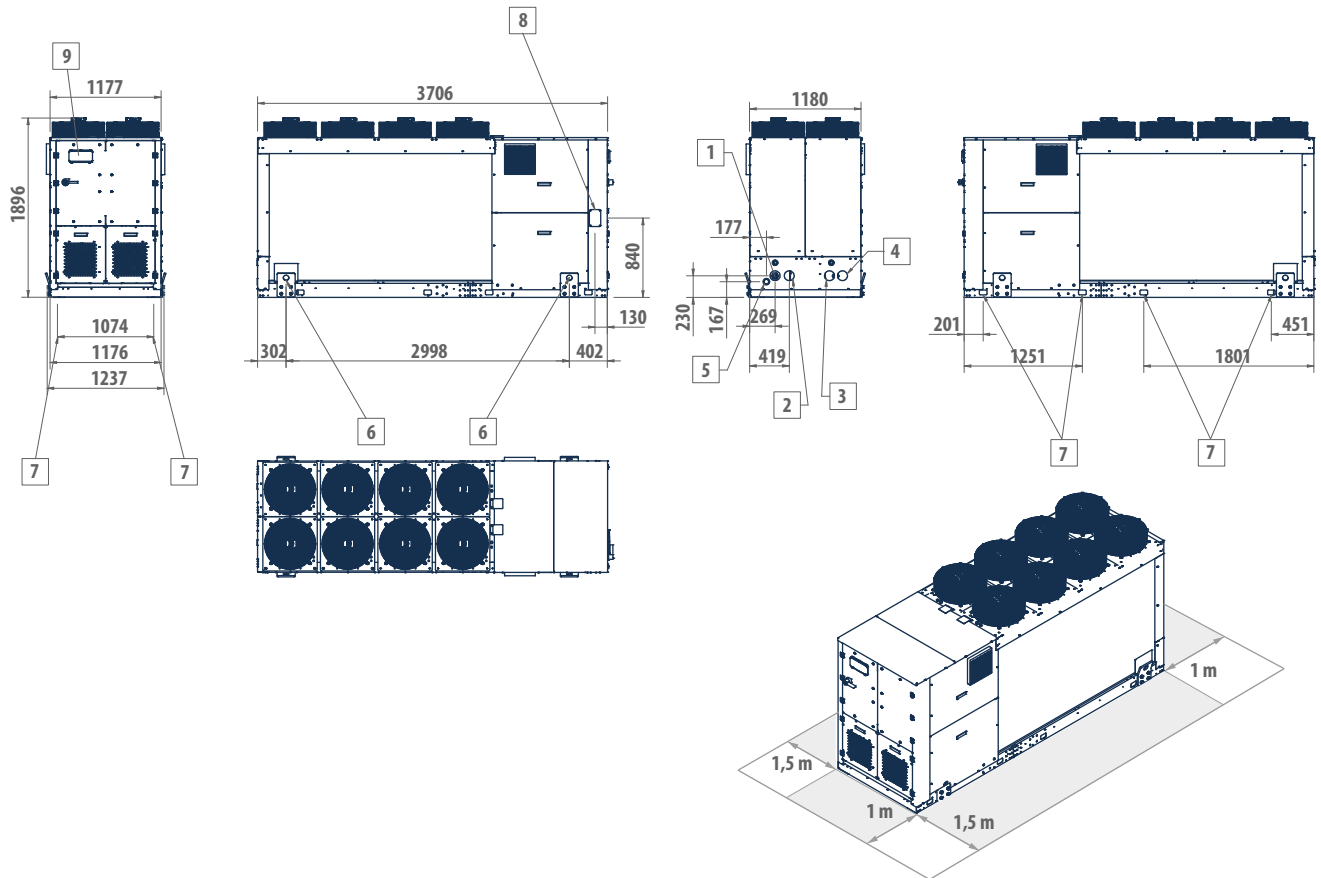

LEGEND

1	Water inlet on user side 2 1/2" VIC
2	Water outlet user 2 1/2" VIC
3	Heat recovery hot water inlet 2 1/2" VIC
4	Recovery hot water outlet recovery 2 1/2" VIC
5	Water drainage tank 1/2" F
6	Lifting points
7	Vibration dumpers
8	Power supply input
9	User interface

Total heat recovery multi-purpose units with low GWP refrigerant - MLE

Total heat recovery multi-purpose units with low GWP refrigerants MLE

DIMENSIONAL DRAWINGS

MLE 144 - 154 - 174

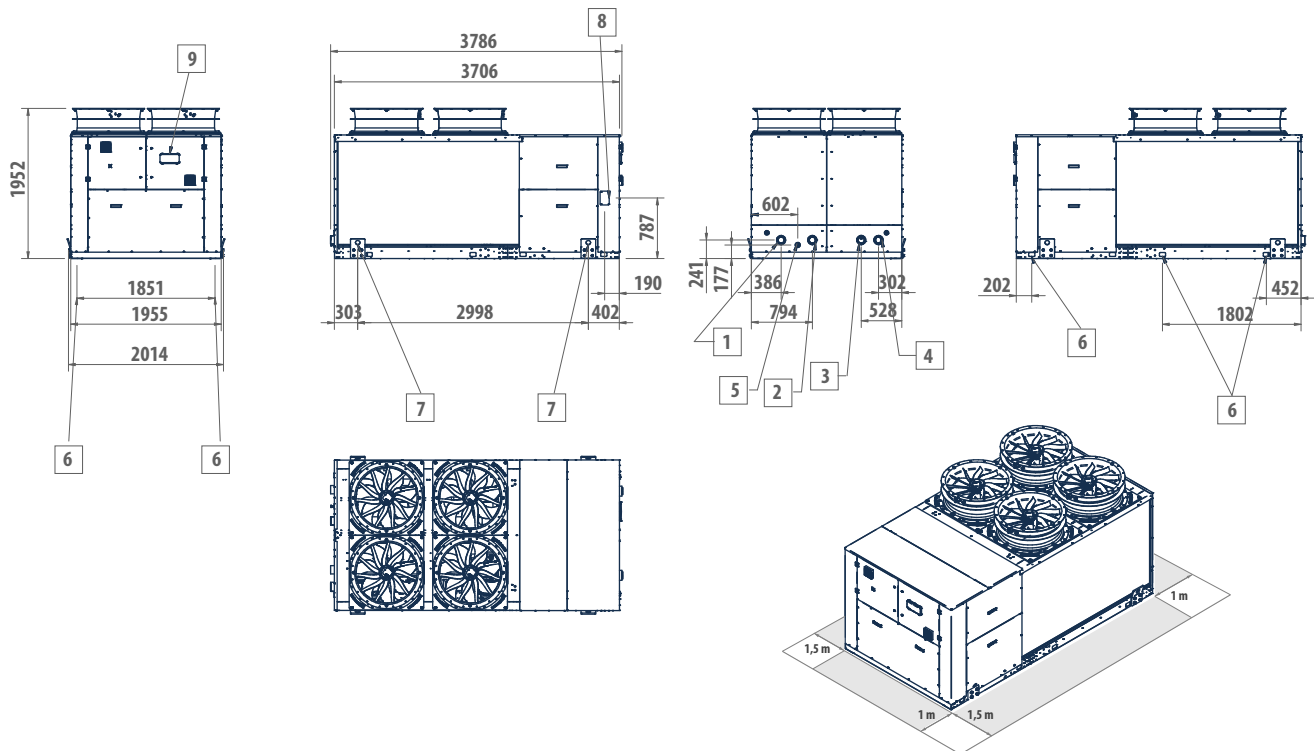

LEGEND

1	Water inlet on user side 3" VIC
2	Water outlet user 3" VIC
3	Heat recovery hot water inlet 3" VIC
4	Recovery hot water outlet recovery 3" VIC
5	Water drainage tank 1/2" F
6	Vibration dumpers
7	Lifting points
8	Power supply input
9	User interface

DIMENSIONAL DRAWINGS

MLE 204 - 244

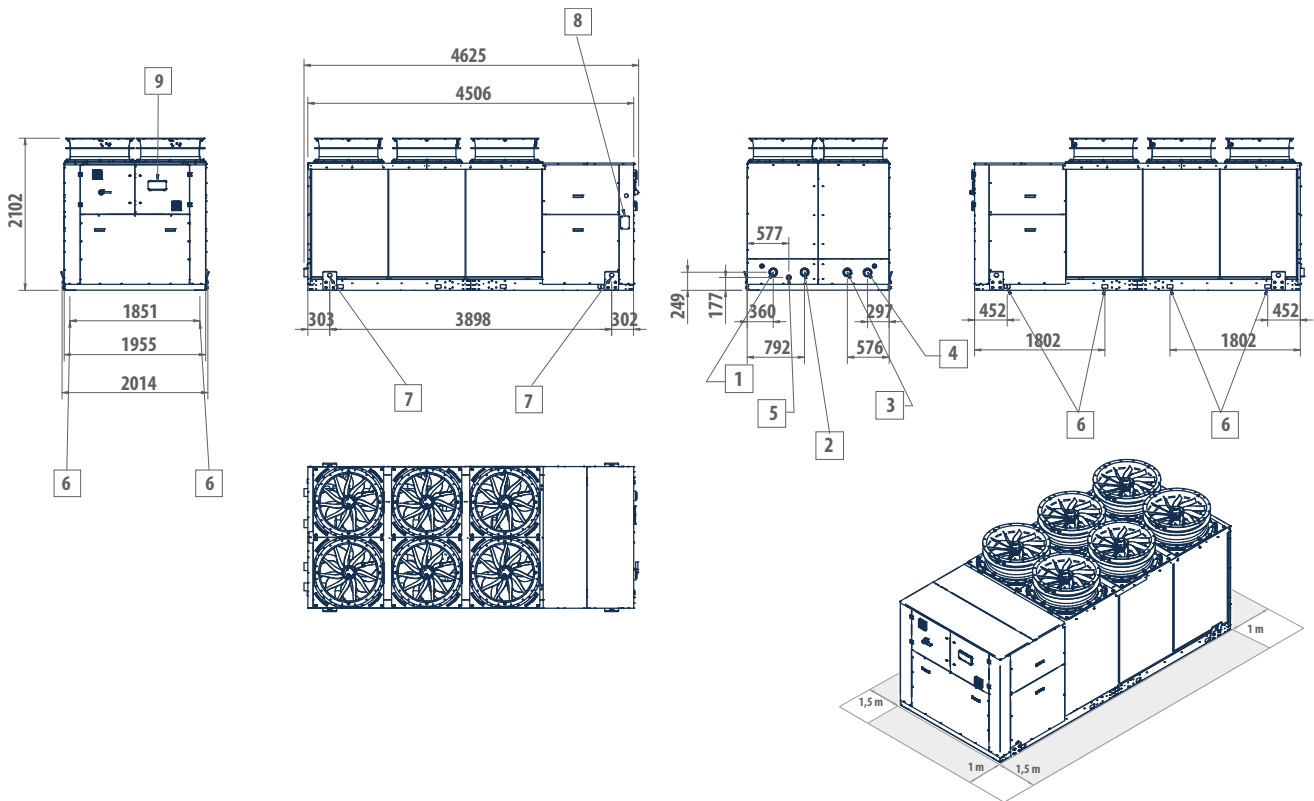

LEGEND

1	Water inlet on user side 3" VIC
2	Water outlet user 3" VIC
3	Heat recovery hot water inlet 3" VIC
4	Recovery hot water outlet recovery 3" VIC
5	Water drainage tank 1/2" F
6	Vibration dumpers
7	Lifting points
8	Power supply input
9	User interface

Total heat recovery multi-purpose units with low GWP refrigerant - MLE