

Customer: *UNKNOWN*

Cod.: C06M12.YXXX

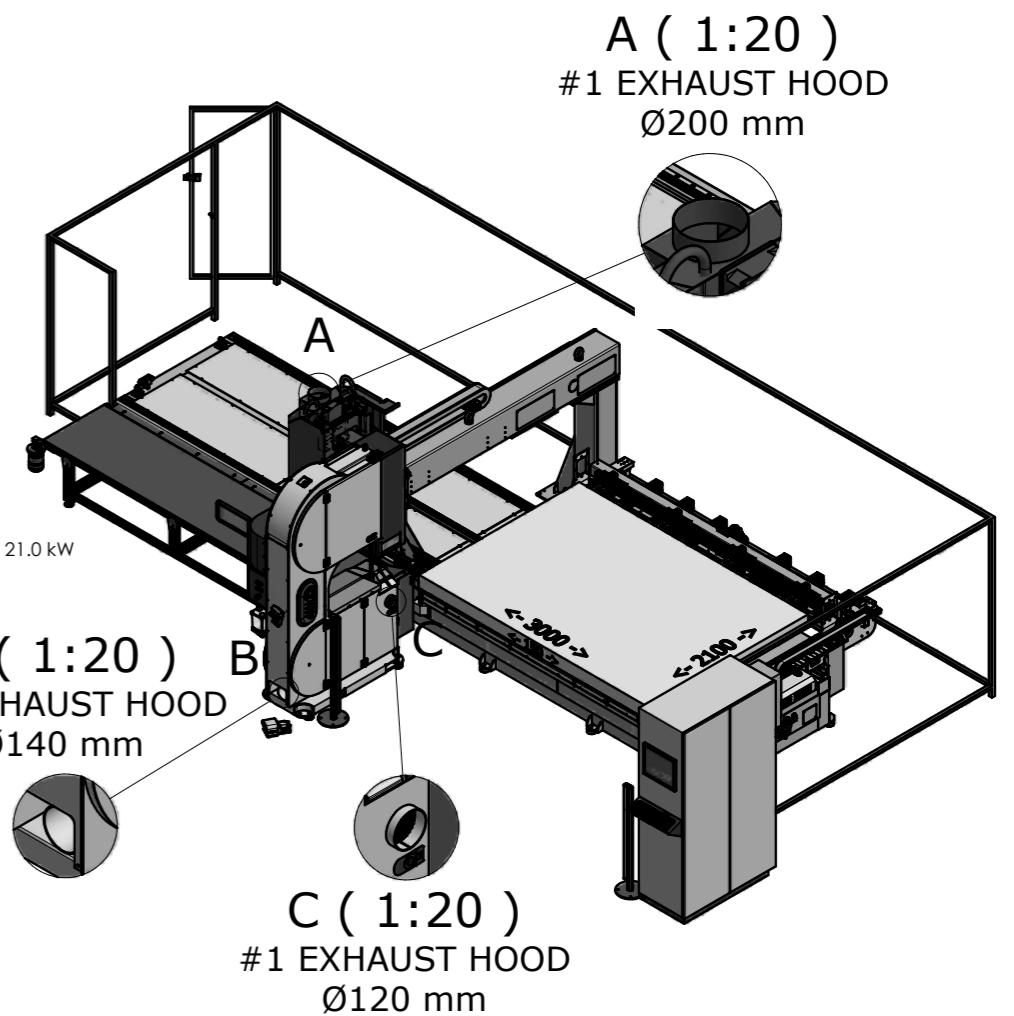
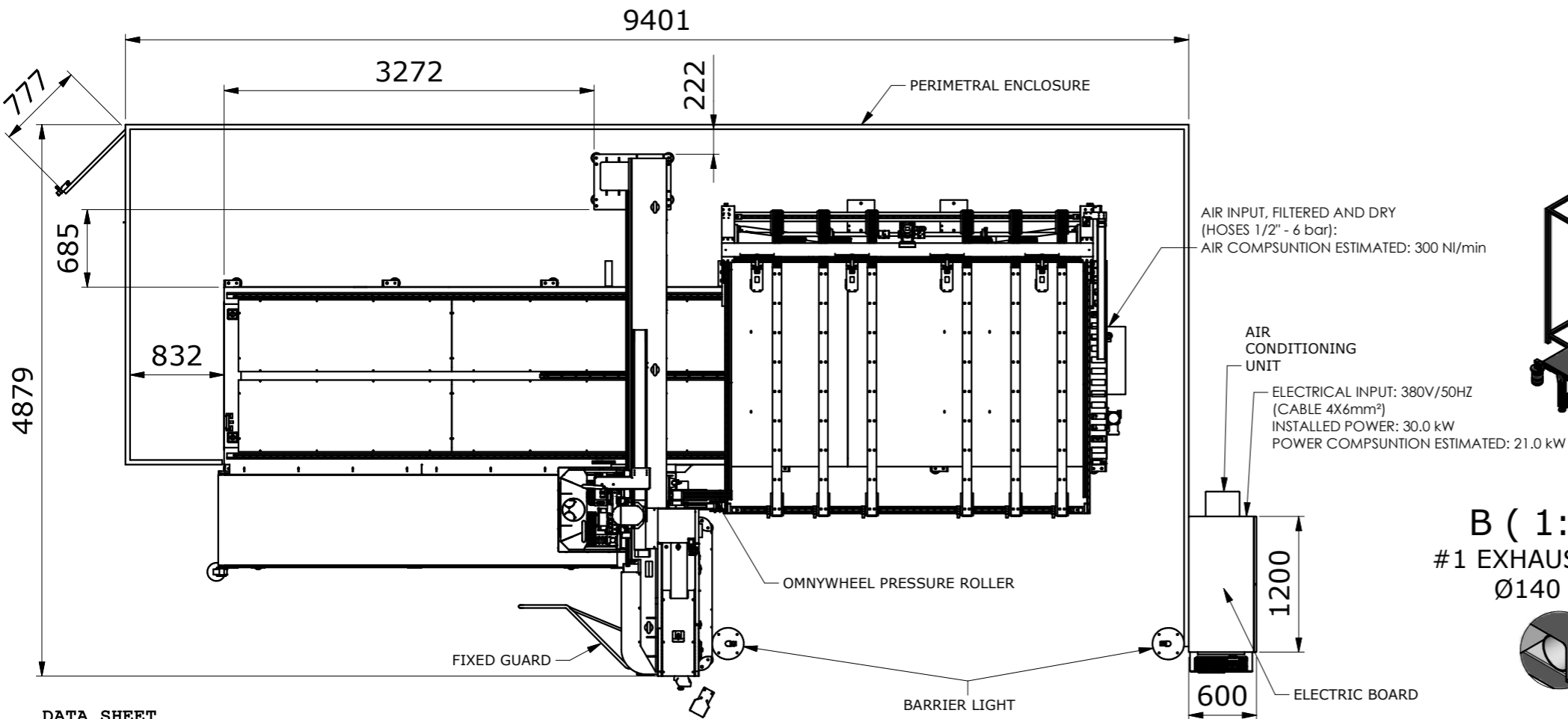
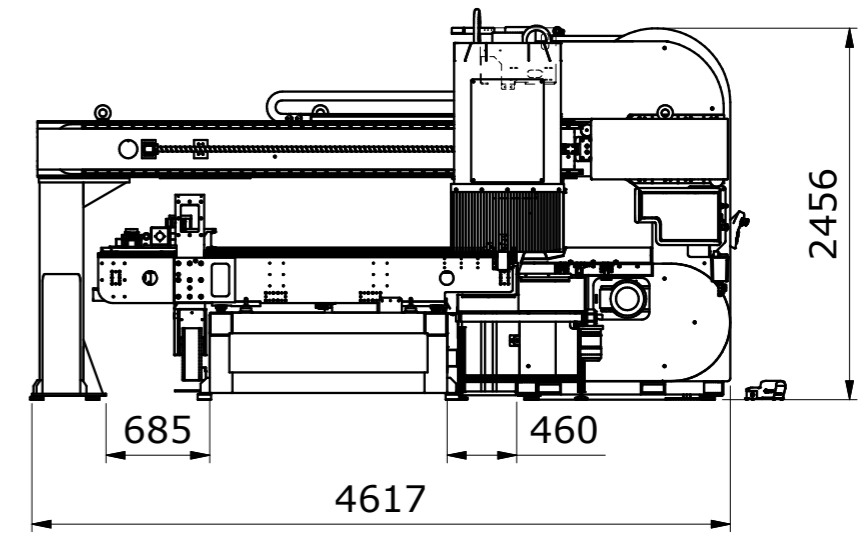
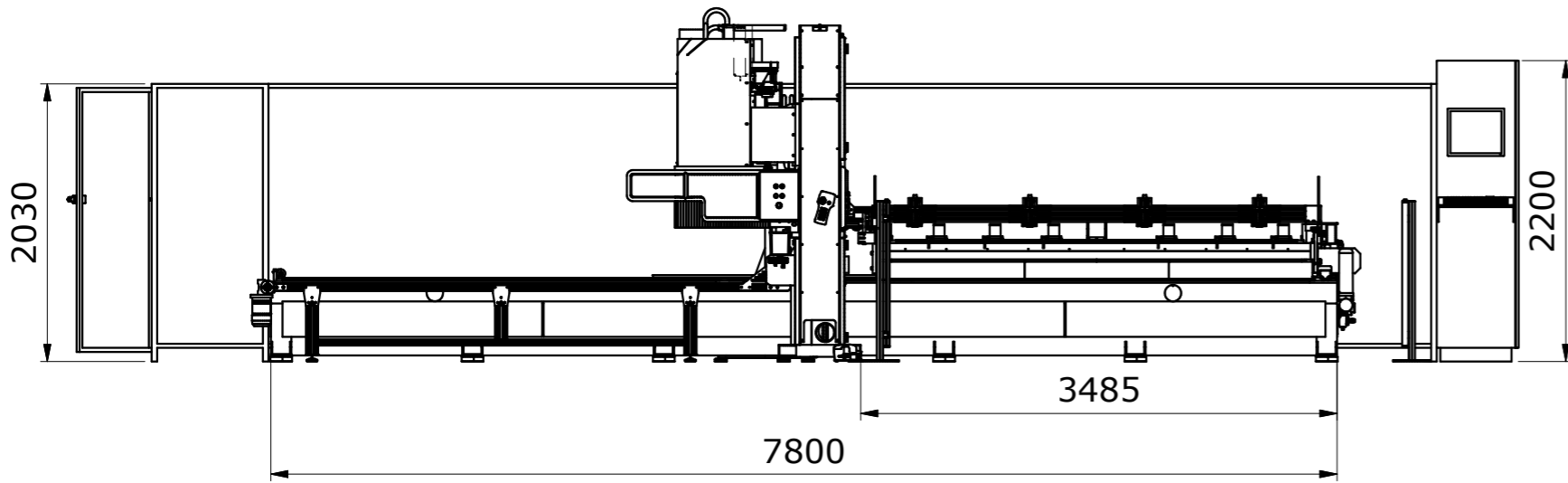

**DATA SHEET**

- CUTTING LENGTH IN X: 3000MM
- CUTTING WIDTH IN Y: 2100MM
- CUTTING HEIGHT: 0-150MM
- CUTTING DEPTH: 0-770MM
- CUTTING ANGLE: +/- 90°
- FLYWHEELS STEEL: D.800MM
- SAW BLADE DIMENSIONS: 5450MM X (13X0.9
- SAW BLADE MOTOR: 7.5KW
- FEED SPEED: 0-25MT/MIN
- WEIGHT: 7.000KG

# MASTERCUT P3000X2100

