



SWISS  
MADE



**technica**  
technology gmbh

# ZENTROFLEX

CENTER HOLE  
GRINDING MACHINES





1. About Us
2. Process
3. M Series
4. SA Series
5. A Series
6. Jumbo Series
7. Applications
8. Technologies
9. Accessories
10. Refurbishing  
& Remastering

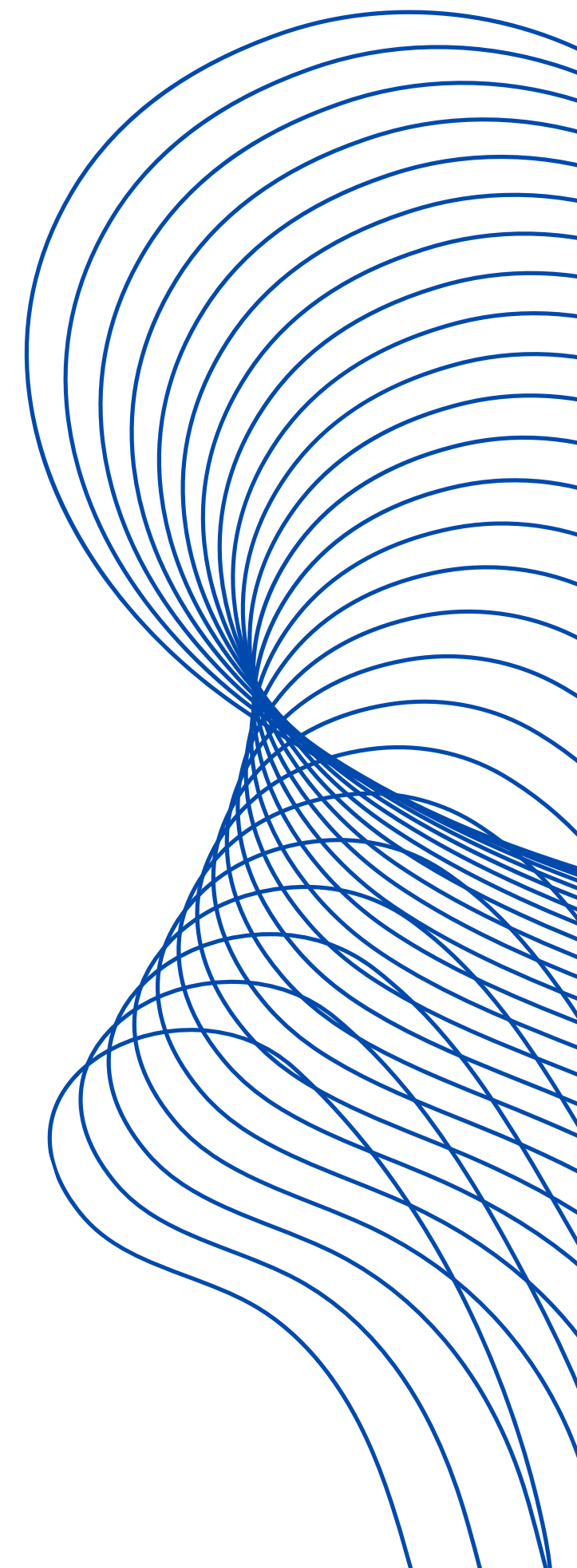

# 01

# ABOUT US

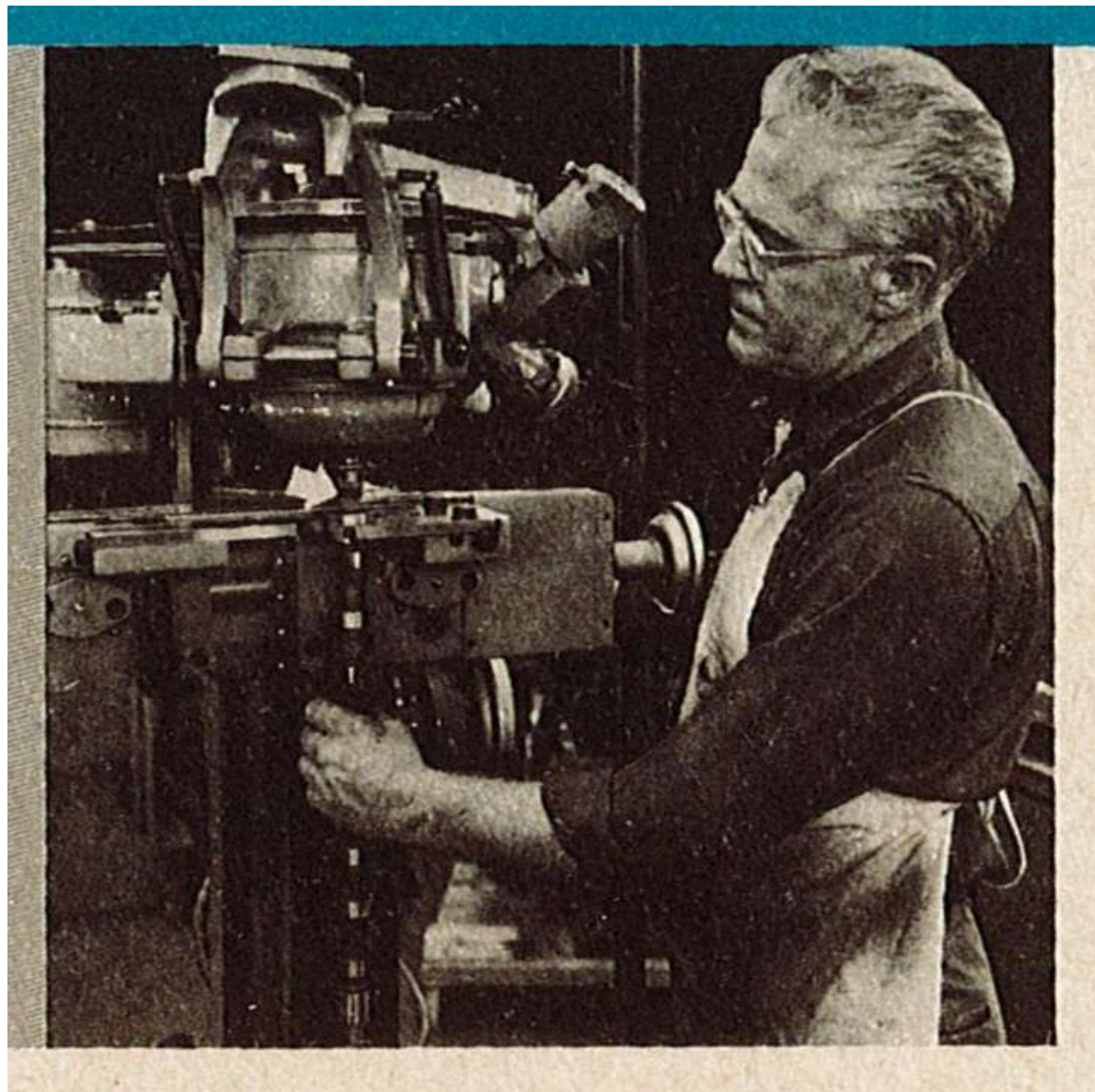

Technica has shaped today's center hole grinding machines and developed the techniques and technologies of center hole grinding. With our experience since 1941, we have been producing the most precise center hole grinding machines.

Hundreds of Technica brand machines, produced with Swiss precision and quality, are still operating at our well-known customers' facilities even after more than 50 years.

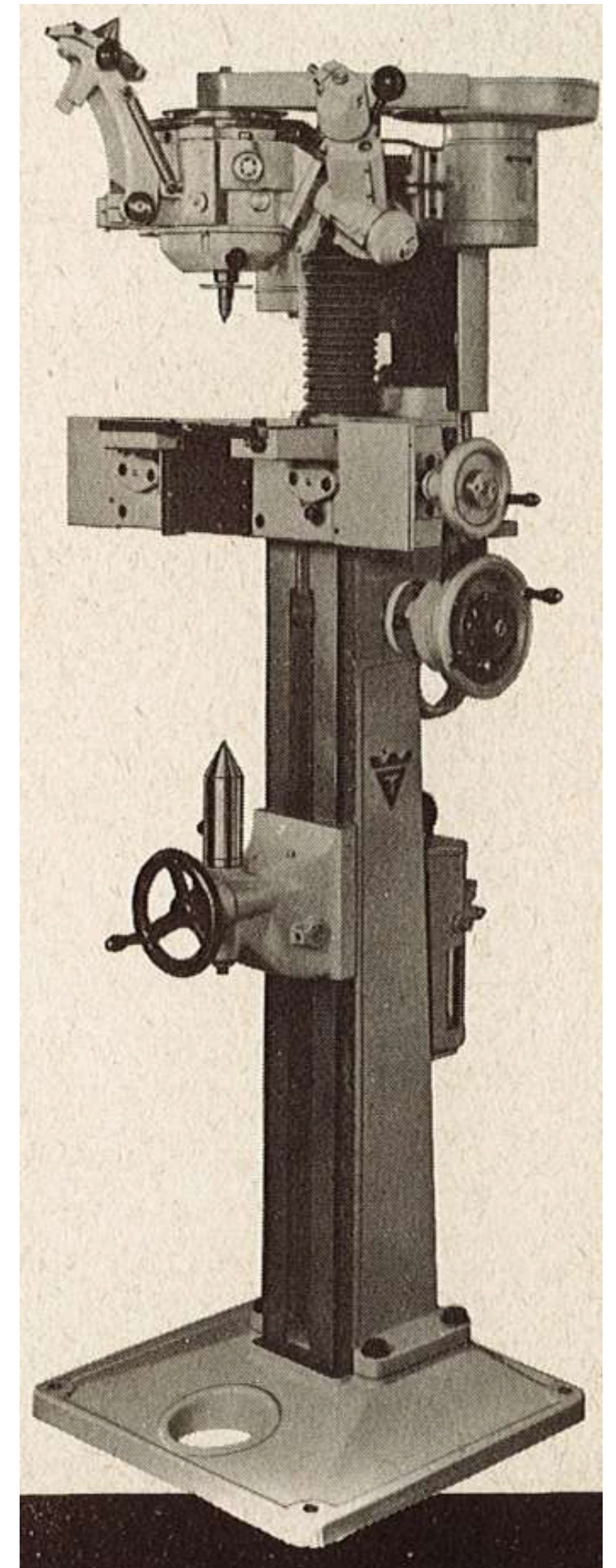

# 02

# PROCESS

1

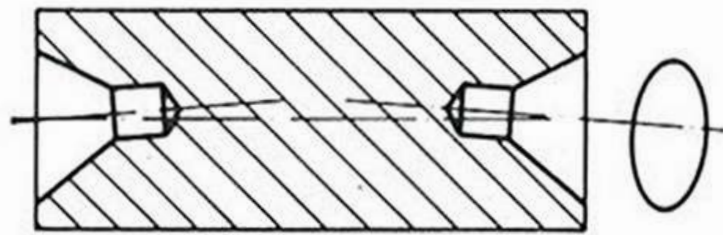

Poor alignment,  
Concentricity

2

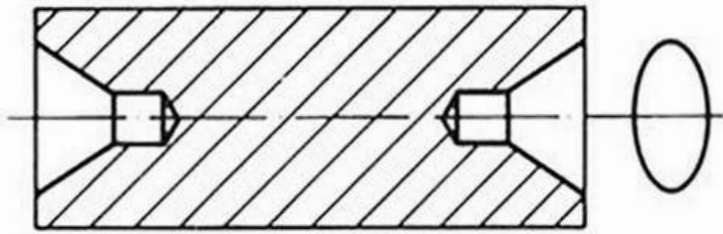

Out of round,  
Circularity

3

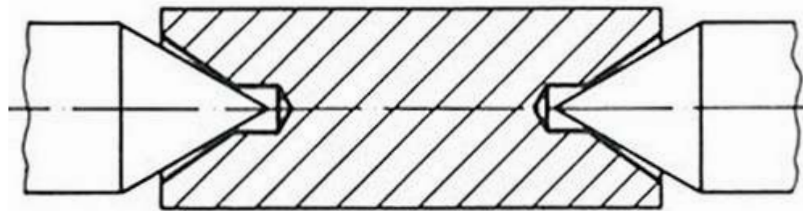

Angle too  
large

4

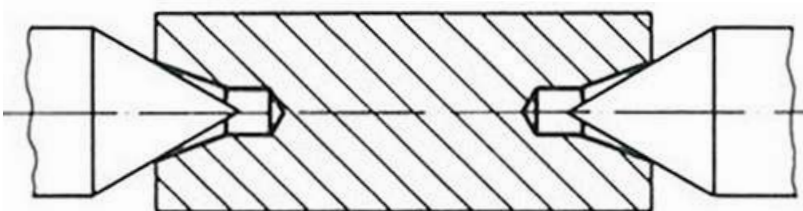

Angle too  
small

5

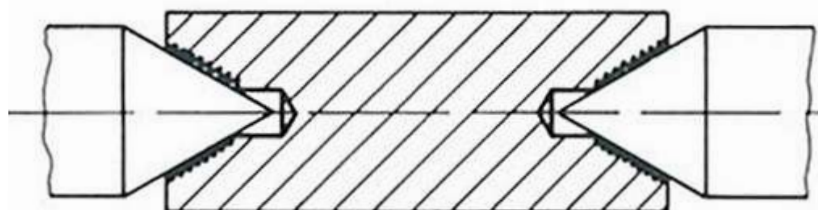

Poor  
surface finish

After heat treatment, workpieces often become distorted, causing the centers to be misaligned or deformed.

Clamping from distorted centers on a cylindrical grinding machine causes tolerance loss, longer grinding times, reduced grinding wheel life, increased labor, and higher costs.

# PROCESS

02

When the centers are properly positioned and within tolerances, high precision can be achieved, and both grinding wheel and labor costs decrease significantly due to shorter grinding times. The result is high-quality work at a lower cost.

The correct concentricity, geometry and surface quality of the centers directly affect the quality of cylindrical grinding.

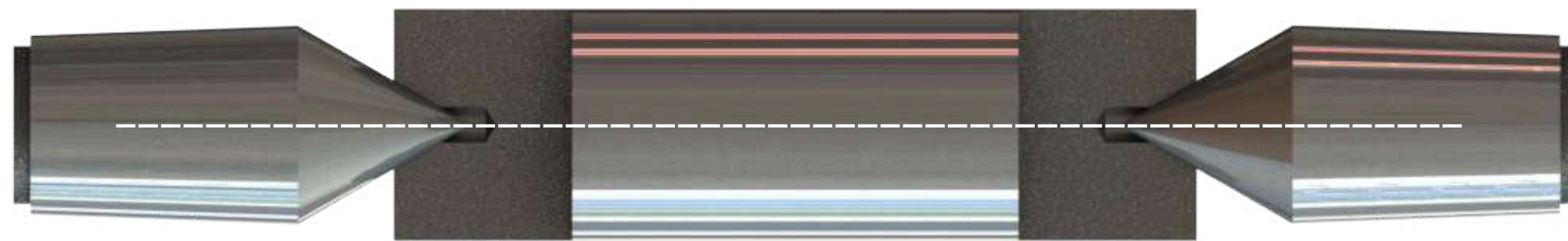

Properly aligned center holes and centers

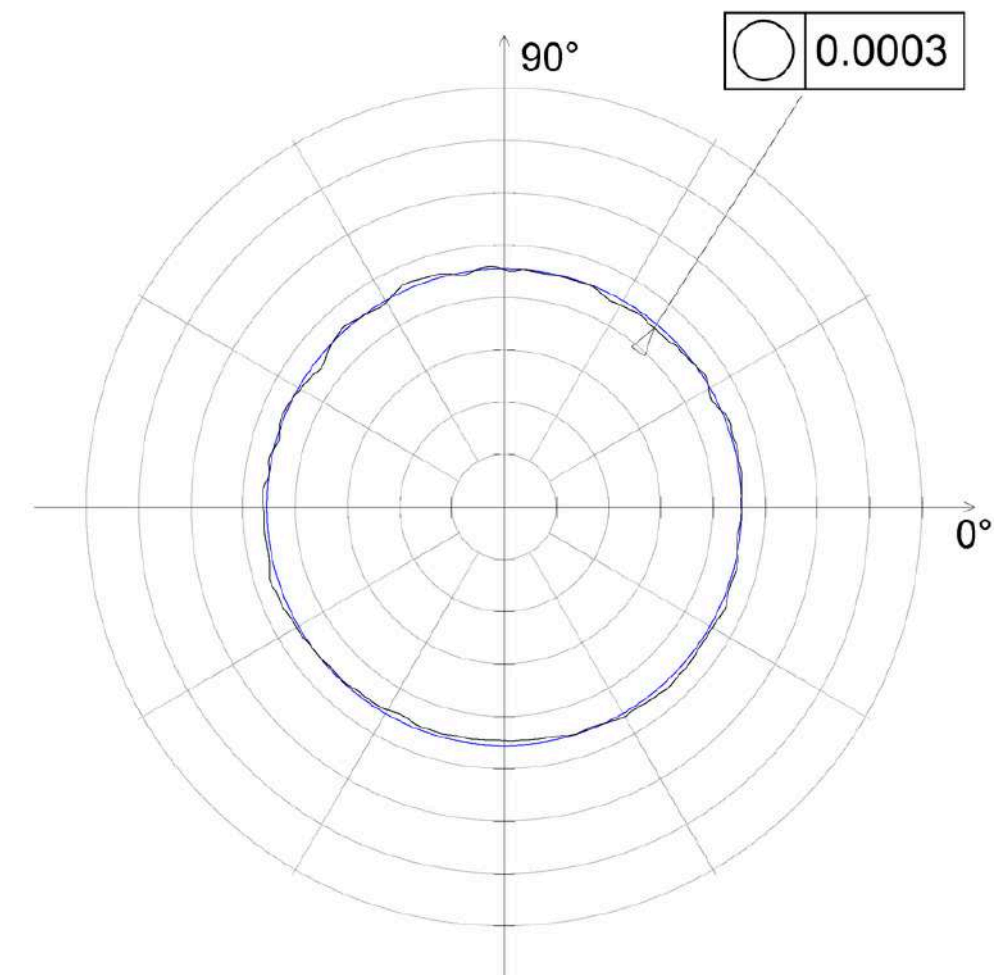



SWISS  
MADE



03

## ZENTROFLEX M SERIES

The Zentrox M series center hole grinding machines are engineered to deliver high-precision cylindrical grinding in the aerospace, automotive, and machinery industries. Moreover, the Zentrox M series offers an ideal solution for restoring distorted workpieces after heat treatment or repairing high-precision equipment to recover their original accuracy.

Thanks to manual adjustment options for each function, the Zentrox is ideal for center holes on workpieces of various sizes and shapes. For small to medium production volumes, the Zentrox M series center hole grinding machines are the perfect solution. Like a Swiss Army knife, the M models are adaptable and always ready to assist you whenever needed.



SWISS  
MADE



04

## ZENTROFLEX SA SERIES

Zentrox SA models offer digital grinding, shorter cycle times, and consistent precision. Thanks to the numerically controlled Z-axis and sophisticated control panel, the SA models enable highly precise and accurate grinding. All grinding parameters can be easily and individually adjusted for different center holes and stored in memory. Aside from loading and unloading, constant supervision by a machine operator is not required.

During the grinding process, the operator is free. The grinding program saving feature also reduces the need for operator experience and minimizes the risk of human errors. Optional upgrades for maximum efficiency include sound sensors for fully automated grinding and measuring sensors for measuring and setting up parts. The Zentrox Type SA represents maximum efficiency and is the optimal solution for demanding grinding tasks with small and medium volumes.



SWISS  
MADE



05

## ZENTROFLEX A SERIES

Equipped with a 6-axis robot arm and servo drives on all axes, Zentrox A models operate completely autonomously. All loading and unloading operations are performed by the robot arm. All axis movements are also controlled autonomously by servo motors and the digital control panel. Additionally, the machine automatically sets itself up when changing parts without slowing down production flow. Cone dressing and compensation are performed automatically as well.

Thanks to these features, the Zentrox A models can work for long hours without human intervention. It consistently grinds pieces with high quality and precision while eliminating human errors. It ends operator dependency. Thanks to compatible interfaces, the A series can be easily integrated into production lines or networked with various feeding systems. You can efficiently manage large-volume grinding orders with Zentrox A series center hole grinding machines.



**SWISS  
MADE**



**06**

# ZENTROFLEX JUMBO SERIES

## WORKPIECES



### **weight**

up to 1,000 kg  
up to 2,204 lbs



### **width**

up to 300 mm  
up to 11.81"

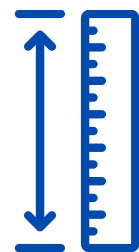

### **length**

up to 2,000 mm  
up to 78.74"

The Jumbo series is specifically designed for precise center hole grinding of oversized workpieces used in heavy industries. Thanks to its robust and massive structure, the Jumbo can easily handle large workpieces. The Jumbo series offers customized solutions, especially for applications in jet engine manufacturing, marine engine construction, wind turbines, and heavy vehicle transmission and engine equipment.

14-<sup>M</sup> - 110  
 SA - 160  
 A - 200

22-<sup>M</sup> - 110  
 SA - 160  
 A - 200

14-<sup>ooo</sup> -110

14-<sup>ooo</sup> -160

14-<sup>ooo</sup> -200

22-<sup>ooo</sup> -110

22-<sup>ooo</sup> -160

22-<sup>ooo</sup> -200



Workpiece Clamping Diameter

Ø 3 - 140 mm  
 Optional up to Ø 210 mm

Ø 3 - 140 mm  
 Optional up to Ø 210 mm

Ø 3 - 140 mm  
 Optional up to Ø 210 mm

Ø 3 - 220 mm  
 Optional up to Ø 310 mm

Ø 3 - 220 mm  
 Optional up to Ø 310 mm

Ø 3 - 220 mm  
 Optional up to Ø 310 mm



Workpiece Diameter

Ø 3 - 310 mm

Ø 3 - 310 mm

Ø 3 - 310 mm

Ø 3 - 400 mm

Ø 3 - 400 mm

Ø 3 - 400 mm



Workpiece Length

20 mm - 1,100 mm

20 mm - 1,600 mm

20 mm - 2,000 mm

20 mm - 1,100 mm

20 mm - 1,600 mm

20 mm - 2,000 mm



Center Hole Diameter

Ø 1 - 60 mm  
 Optional Ø 1 - 100 mm

Ø 1 - 60 mm  
 Optional Ø 1 - 100 mm

Ø 1 - 60 mm  
 Optional Ø 1 - 100 mm

Ø 1 - 60 mm  
 Optional Ø 1 - 100 mm

Ø 1 - 60 mm  
 Optional Ø 1 - 100 mm

Ø 1 - 60 mm  
 Optional Ø 1 - 100 mm



Speed

5,000 rpm  
 45,000 rpm

5,000 rpm  
 45,000 rpm

5,000 rpm  
 45,000 rpm

5,000 rpm  
 45,000 rpm

5,000 rpm  
 45,000 rpm

5,000 rpm  
 45,000 rpm



Workpiece Weight

170 kg  
 Optional up to 220 kg

170 kg  
 Optional up to 220 kg

170 kg  
 Optional up to 220 kg

170 kg  
 Optional up to 220 kg

170 kg  
 Optional up to 220 kg

170 kg  
 Optional up to 220 kg



## AVIATION

The aviation industry uses Zentrox machines to refine the center holes of various components, including:

- 1.Engine Shafts
- 2.Turbine and Compressor Rotors
- 3.Aircraft Propellers and Spindles
- 4.Transmission Components



## MACHINERY

Machinery components, requiring high precision and strict tolerances for reliable operation, require Zentrox machines, such as:

- 1.Spindles
- 2.Tool Holders
- 3.Cutting Tools
- 4.Shafts



## AUTOMOTIVE

Zentrox machines are indispensable for producing a range of automotive components, such as:

- 1.Transmission Shafts
- 2.Crankshafts
- 3.Camshafts
- 4.Gear Components

# APPLICATIONS

07



## DEFENCE

Zentrox machines are used in the production of various defense components, including:

1. Aerospace Equipment
2. Optical and Radar Systems
3. Military Vehicle Equipment



## E-MOBILITY

Zentrox machines are essential for manufacturing key components in e-mobility, such as:

1. Electric Motor Shafts
1. Gearboxes and Transmission Shafts
3. Rotor and Stator Assemblies
4. Axles and Wheel Hubs

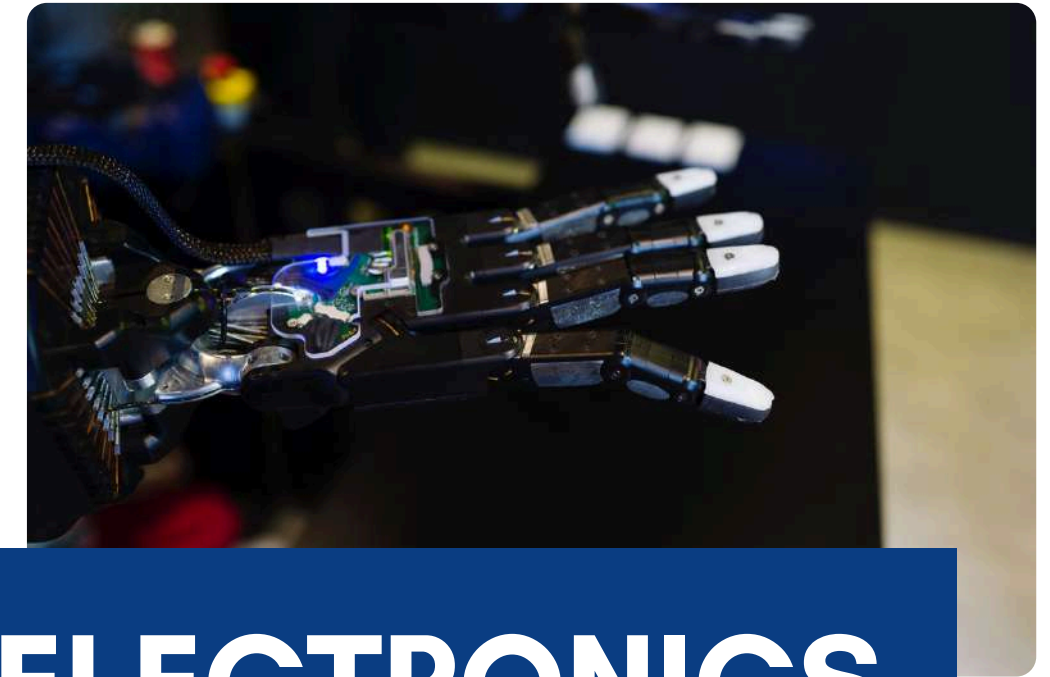

## ELECTRONICS

Zentrox machines are essential for producing various mechanical components within electronic devices:

1. Micro-Motor Shafts
2. Spindle Assemblies
3. Miniature Gears and Gear Shafts
4. Sensors and Actuators

# TECHNOLOGIES

08

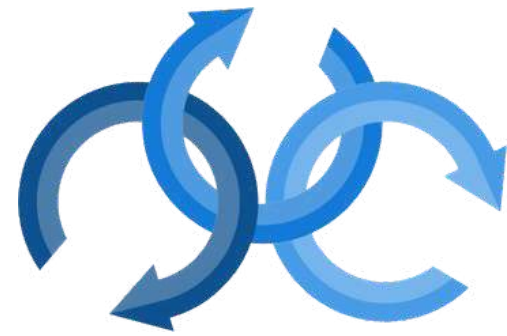

## Quirlig Grinding Technique

The Quirlig Grinding Technique, developed by Technica, executes three independent movements simultaneously. In addition, by integrating a workpiece drive, "3+1" free-movement configuration can be achieved.

By combining rotation, orbital rotation, and stroke movements, the Quirlig Grinding Technique creates a cross-hatched grinding pattern within center holes.

The cross-hatched grinding pattern retains oil, establishing a micro oil film between the center and the center hole during cylindrical grinding. As a result, undesirable "dry running" during cylindrical grinding is eliminated, and ensuring high precision cylinder grinding.

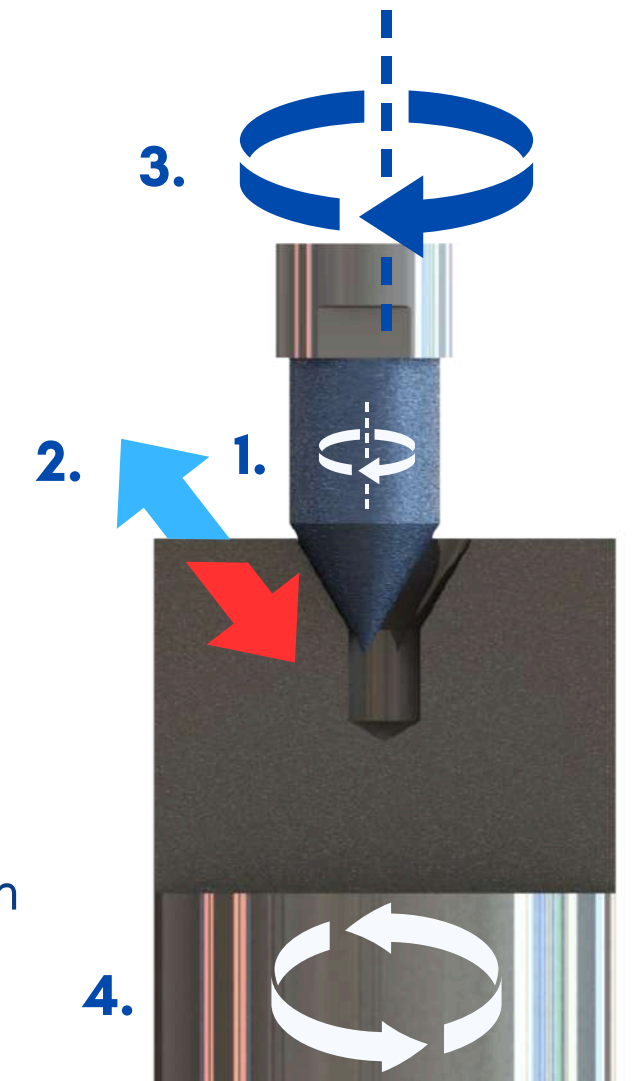

1. Rotation
2. Stroke Movement
3. Orbital Rotation
4. Workpiece Rotation

Crosshatched Grinding Pattern

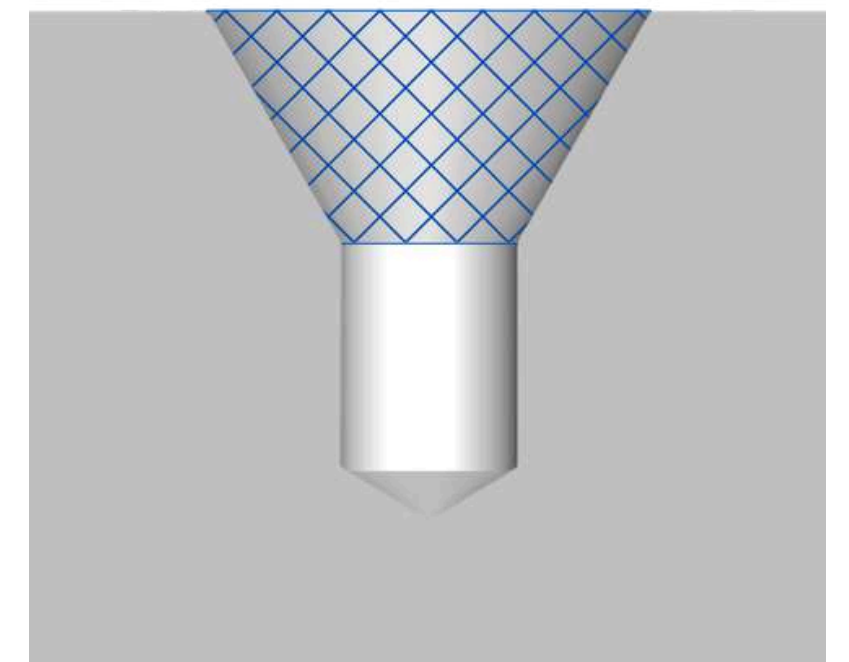

# TECHNOLOGIES

08

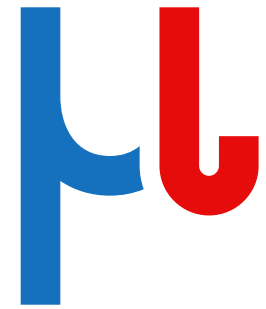

## Sub-Micron Grinding

By employing a specialized bedding system and integrating mechanical grinding heads equipped with sophisticated movement mechanisms developed by Technica, it becomes possible to consistently achieve roundness tolerances below  $1\ \mu\text{m}$ .

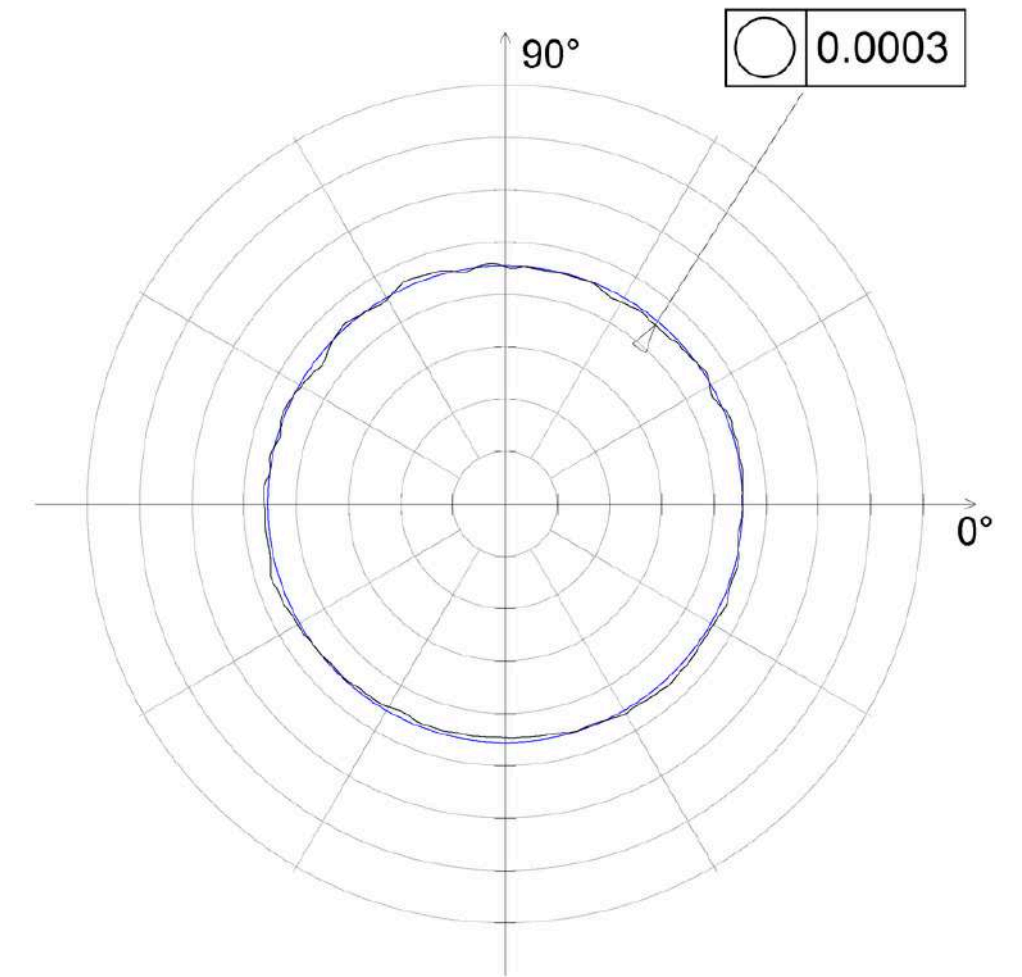

## Digital Control Panel

The Technica Grinding Control Panel allows users to monitor and set grinding parameters, enabling operators to quickly adapt and optimize the grinding process without extensive training or complicated adjustments. In addition to saving grinding programs, it also offers reporting and remote control functions.

**GRINDING  
CONTROL PANEL**

# TECHNOLOGIES

08

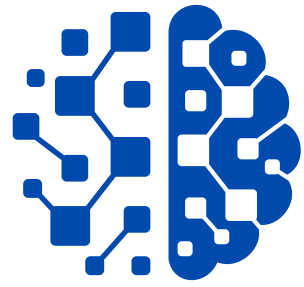

## Smart Grinding

Integrating sound frequency and laser sensors gathers essential data to maintain optimal grinding conditions. Technica's Smart Grinding offers several key advantages: Automatic Length Deviation and Touchpoint Detection, Workpiece Form Deviation Detection, and Fully Automated Grinding.



**SENSOR  
INTEGRATION**



**6-AXIS  
ROBOTIC ARM**

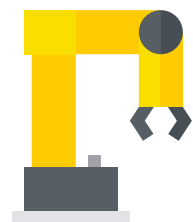

## Robotic Automation

By integrating a 6-axis Staubli robot arm, workpiece handling and grinding processes can be fully automated. This ensures that the grinding process stays consistent, precise, and completely independent of human intervention.

All control functions can be managed from digital control panel, custom-designed for center hole grinding process.

# 09

# ACCESSORIES

To increase the benefits and efficiency of Zentrox Center Hole Grinding Machines, we offer a wide variety of accessories for different types of applications. Thanks to its modular structure, Zentrox Center Hole Grinding Machines can be upgraded over time.



workpiece drive , collet type workpiece holder, three-point steady, dressing device, off-center point, dust extraction

10

# REFURBISHING & REMASTERING

We offer a second chance to your old machines. With the Refurbishing option, we completely restore your old machines that have lost functionality or accuracy through the long years, bringing them back to their original condition.

For those who want more, the Remastering option not only renews your machine but also equips it with the latest technology, allowing you to take advantage of modern advancements.

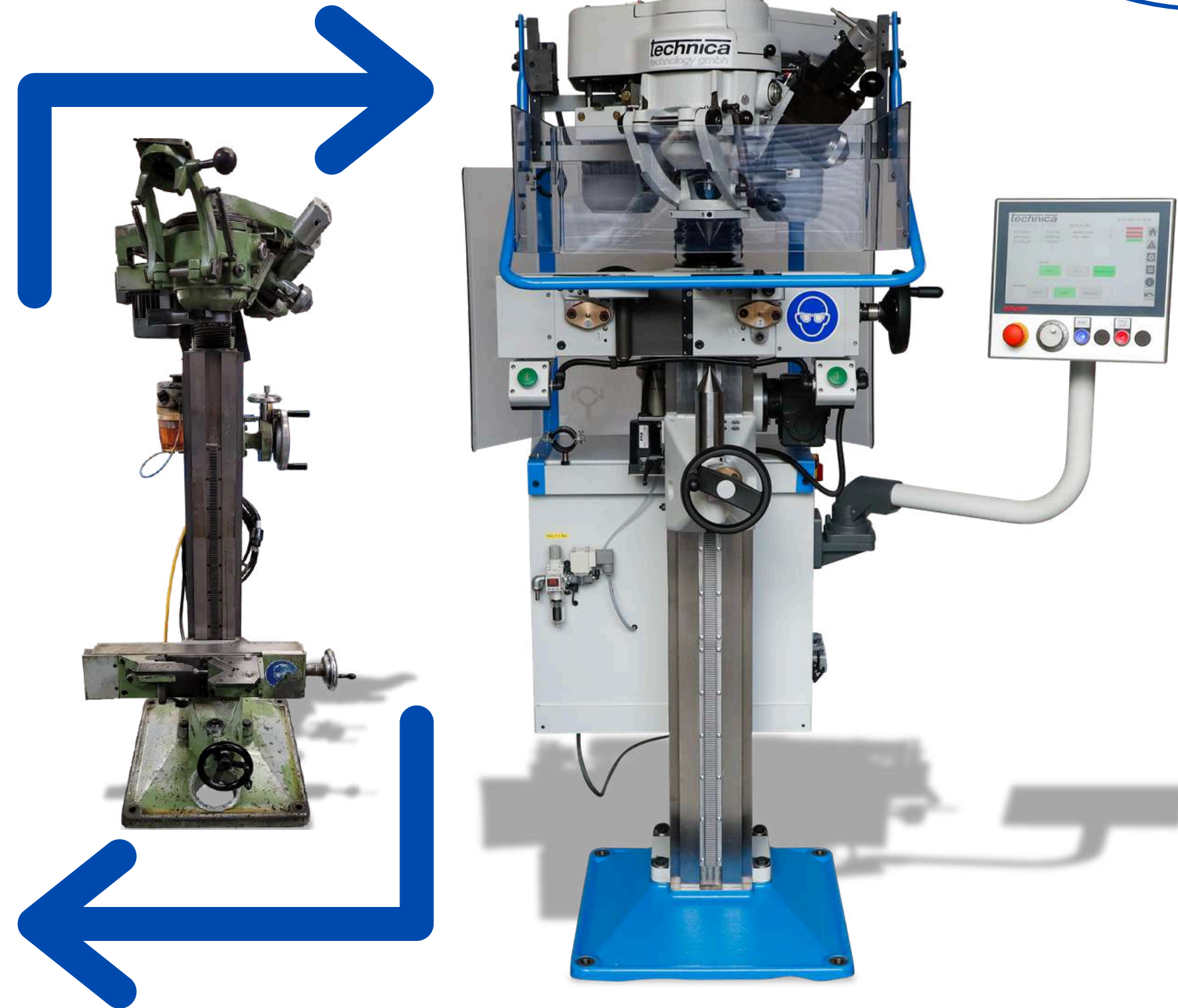

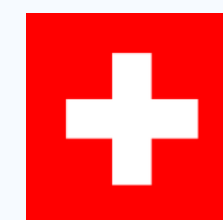
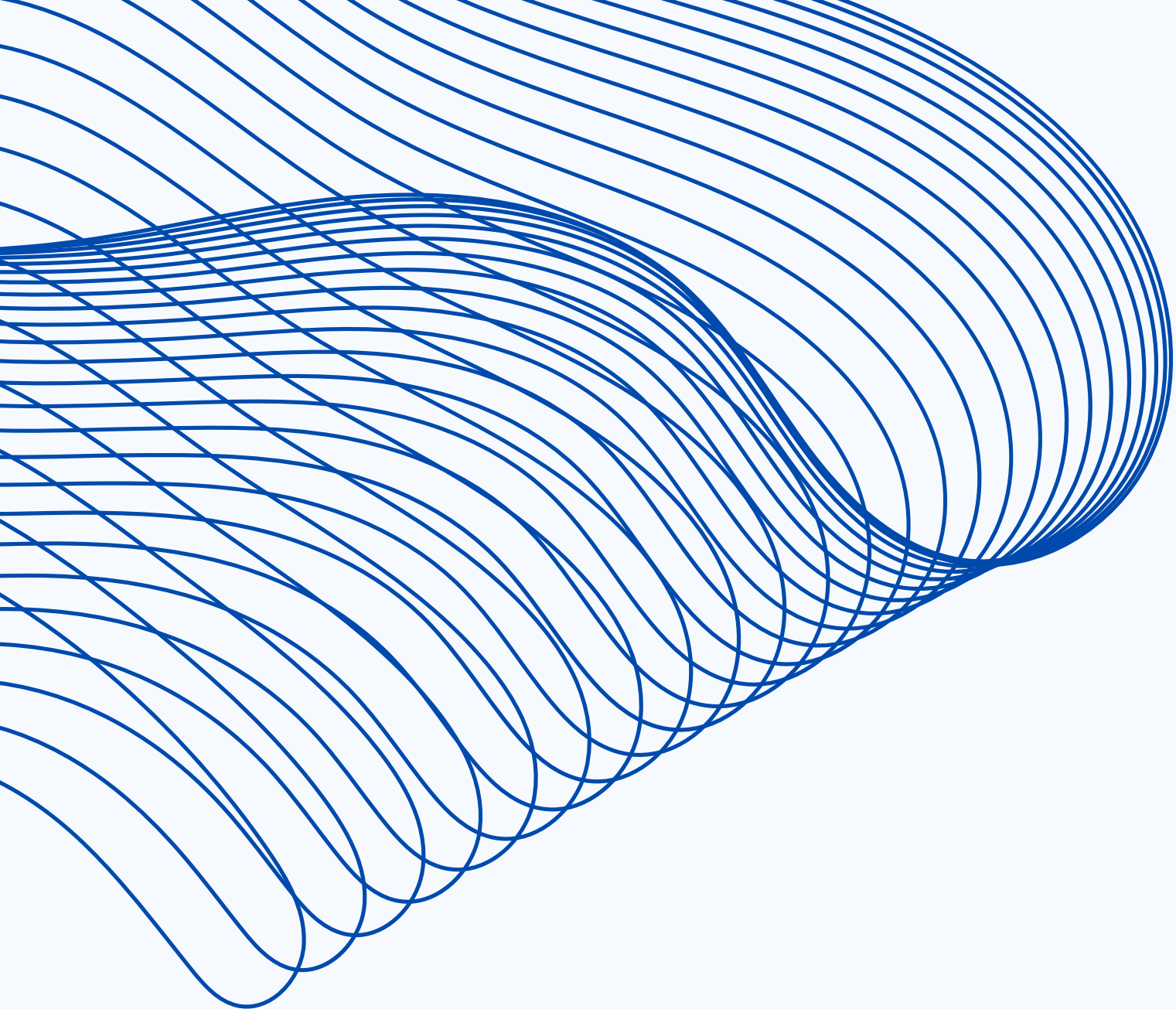

**technica**  
technology gmbh

---

## CONTACT

[www.technica.ch](http://www.technica.ch)

[info@ws-technica.com](mailto:info@ws-technica.com)

+41 32 654 80 60

Gewerbestrasse 10 4552 Derendingen, Switzerland

**KENAN KIZIL**

**SALES MANAGER**

---

[kenan.kizil@ws-technica.com](mailto:kenan.kizil@ws-technica.com)

+41 77 957 16 12

**ZENDEL SAHINI**

**GENERAL MANAGER**

---

[zendel.sahini@ws-technica.com](mailto:zendel.sahini@ws-technica.com)

+41 77 486 68 04