

Vacuum pump

TAWI vacuum pumps are designed with three key features in mind; performance, reliability and sustainability. The direct driven pump minimizes friction and unnecessary wear.



New high performance vacuum pump from TAWI.

TAWI vacuum pump large

This large model is a reliable vacuum pump ideal for vacuum lifters VM60-270 [VM160-300].* When you need to lift heavy, this pump will ensure safe operations with minimal wear and optimal durability. The direct driven pump helps reduce friction and wear, ensuring long term high performance with minimal downtime in your operations.

* TAWI vacuum lifters have new model names from March 2018, old names in brackets.

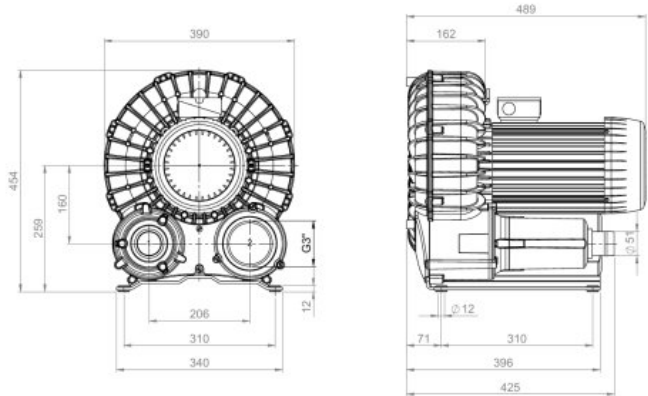

Side channel blower

- double staged, air cooled
- with energy efficient motor (IE3)
- reduced risk of overheating
- silencing hood available

Item no.	50 Hz							60 Hz							IP	kg	Silencing hood
	kW	V ±10%	Certification	rpm	A	dB(A)*	kW	V ±10%	Certification	rpm	A	dB(A)*					
602000	3.0	Δ230/Y400	IE3/UL/CSA	2940	10.9/6.3	71.1	3.6	Δ265/Y460 Δ230/Y400	IE3/UL/CSA	3530 3505	10.8/6.25 11.5/6.6	73	55	54	662000		
602200	3.0	Δ200/Y350	IE3	2940	12.6/7.3	71.1	3.6	Δ220/Y380-400 Δ200/Y350	IE3	3530 3505	12.6/7.3-7.2 13.2/7.55	73	55	54	662000		
602300	-	-	-	-	-	71.1	3.6	YY230/Y460 Δ208	IE3/UL/CSA	3525 3480	10.6/6.2 13.0	73	55	54	662000		
602400	3.0	Y500	IE3/UL/CSA	2910	5.0	71.1	3.6	Y575	IE3/UL/CSA	3510	3.75	73	55	54	662000		

* DIN EN ISO 3744 (KpA = 3 dB(A)) Interval of 1m, at medium load



TAWI AB Box 10205 434 23 Kungälv, SWEDEN
Tel. +46 (0)300 185 00 info@tawi.com
www.TAWI.com