



## **ERGONOMIC POSITIONER WITH ROTATING DEVICE Model SLC**

### ***OPERATION - MAINTENANCE AND SPARE PARTS INSTRUCTION MANUAL***



**SIDEROS MACHINERY S.r.l. Ugo Foscolo 16/18 - 29027 Podenzano (Piacenza) –  
ITALY**



## MACHINE IDENTIFICATION

<b>Model</b>	
<b>Serial Number (S/N)</b>	



# **ERGONOMIC POSITIONER WITH ROTATING DEVICE Model SLC**

## **LIST OF CONTENT**

- 1 - PART A - INSTALLATION AND OPERATIONAL INSTRUCTIONS**
- 2 - PART B - MAINTENANCE**
- 3 - PART C – CHECK REGISTER**



### **ATTENTION !!**

Read instructions manual before using

# PART A

## INSTALLATION AND OPERATIONAL INSTRUCTIONS

### INDEX

#### **A.1 - DESCRIPTION OF THE POSITIONER**

- A.1.1 - GENERAL INFORMATION
- A.1.2 - SPECIFIC USE OF THE POSITIONER
- A.1.3 - OPTIONALS

#### **A.2 - CONSTRUCTIVE FEATURES**

- A.2.1 - GENERAL DRAWING
- A.2.2 - FIXING HOLES ON ROTATING PLATES

#### **A.3 - TECHNICAL FEATURES, SAFETY PRECAUTIONS AND WORKING LIMITS**

- A.3.1 - TECHNICAL FEATURES
- A.3.2 - FACSIMILE OF THE MACHINE PLATES
- A.3.3 - OBLIGATIONS
- A.3.4 - PROHIBITIONS
- A.3.5 - RESIDUAL RISKS
- A.3.6 - IMPROPER USAGE
- A.3.7 - NOISES AND VIBRATIONS
- A.3.8 - SUITABLE ENVIRONMENTAL CONDITIONS FOR USAGE OF THE LIFT

#### **A.4 - POSITIONING AND INSTALLATION**

- A.4.1 - LIFTING AND TRANSFERRING OF THE MACHINE
- A.4.2 - POSITIONING AND INSTALLATION OF THE MACHINE IN THE WORKING AREA
- A.4.3 - ELECTRICAL CONNECTIONS
  - A.4.3.1 - *ELECTRICAL CONNECTION OF THE MASS SYSTEM FOR WELDING MACHINE (OPTIONAL)*

#### **A.5 - DISASSEMBLING-SHIFTING-STORING**

#### **A.6 – DEMOLITION - WASTE DISPOSAL**

## **A.1 - DESCRIPTION OF THE POSITIONER**

### **A.1.1 – GENERAL INFORMATION**

The SIDEROS MACHINERY ergonomic positioner with rotating device model SLC is an equipment which allows the lifting and the rotation of welded frame.

The lifting is of mechanical type by means of gear motor and screw-nut connected to the load-supporting device composed of a steel bracket. The rotation is of mechanical type by means of gear motor coupled with a self-braking motor.

The control is by a control unit supplied and installed on master column.

### **A.1.2 – SPECIFIC USE OF THE POSITIONER**

The SIDEROS MACHINERY ergonomic positioner model SLC has been designed and manufactured to lift and turn welded frames with the following features:

1. Load less than the whole capacity of the two columns (See table A.3.1 – Part A)
2. Maximum load on each column not superior than half of the maximum capacity.
3. Frames and constructive works mounted on columns have to comply with the shown features, with the obligation not to exceed the maximum torque in eccentricity condition (See table A.3.1 – Part A).
4. Maximum width of frames and of equipment on them have to be placed to avoid collisions with ground during the rotation, in the safety area previously established.

**In case of features not correspondent to these requirements, absolutely contact Technical dept. of SIDEROS MACHINERY. (☎ 0523-524066 – E-mail: [support@siderosengineering.com](mailto:support@siderosengineering.com)).**

### **A.1.3 – OPTIONALS**

Different series of optional can be separately supplied, among which: System with a self-learning software, possibility to directly connect the cable of mass for the welding machine to the column for a better electrical transmission.

## **A.2 – CONSTRUCTIVE FEATURES**

### **A.2.1 – GENERAL DRAWING**

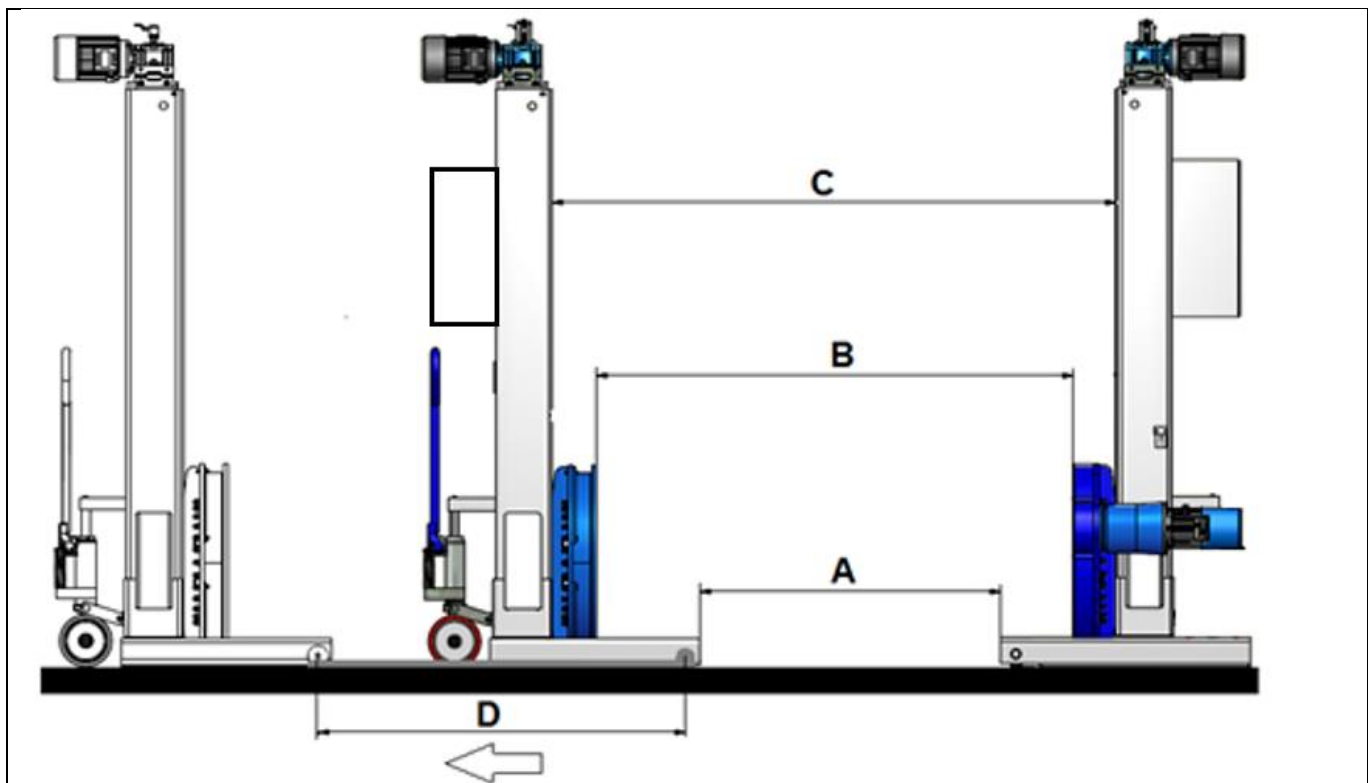

- A= MINIMUM DISTANCE BETWEEN COLUMNS**  
**B= DISTANCE BETWEEN FLANGES (DISTANCE BETWEEN THE FIXING POINTS OF THE WORKPIECE)**  
**C= DISTANCE BETWEEN COLUMNS (MAXIMUM DIMENSION OF THE WORKPIECE)**  
**D= MAXIMUM ADMITTED TRANSFER OF SLAVE COLUMN WITH AUXILIARY RAILS (optional)**



**SLC 50**

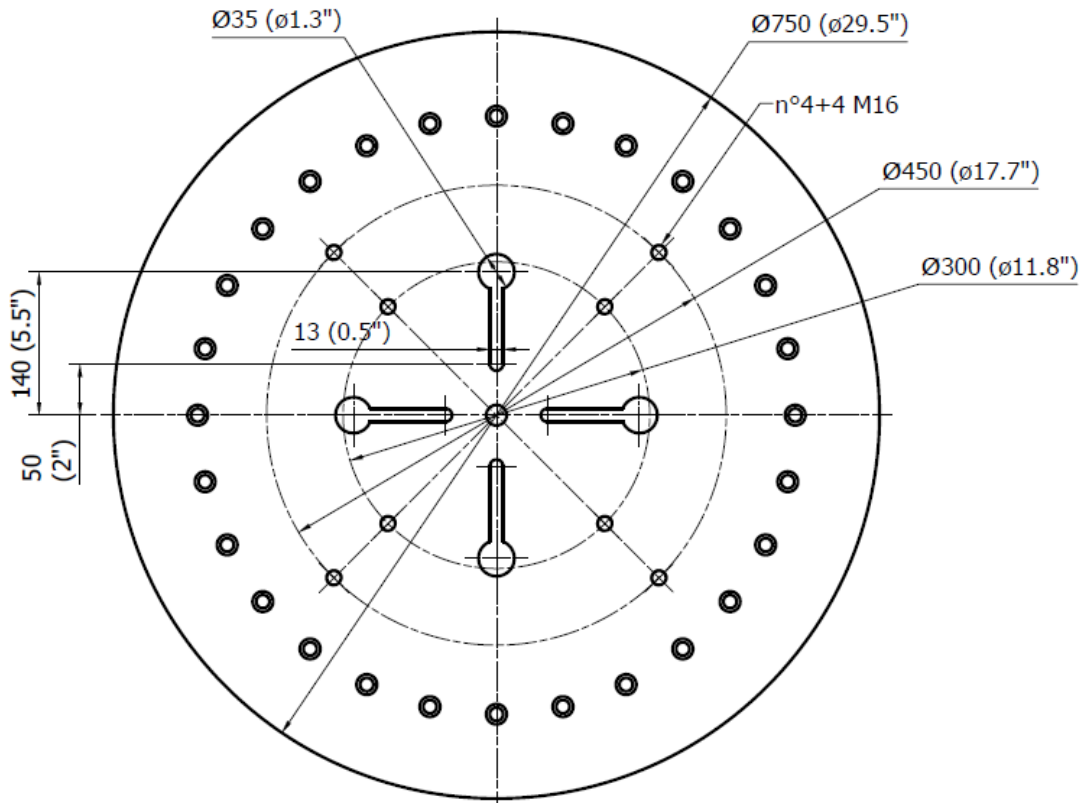

**SLC 60**

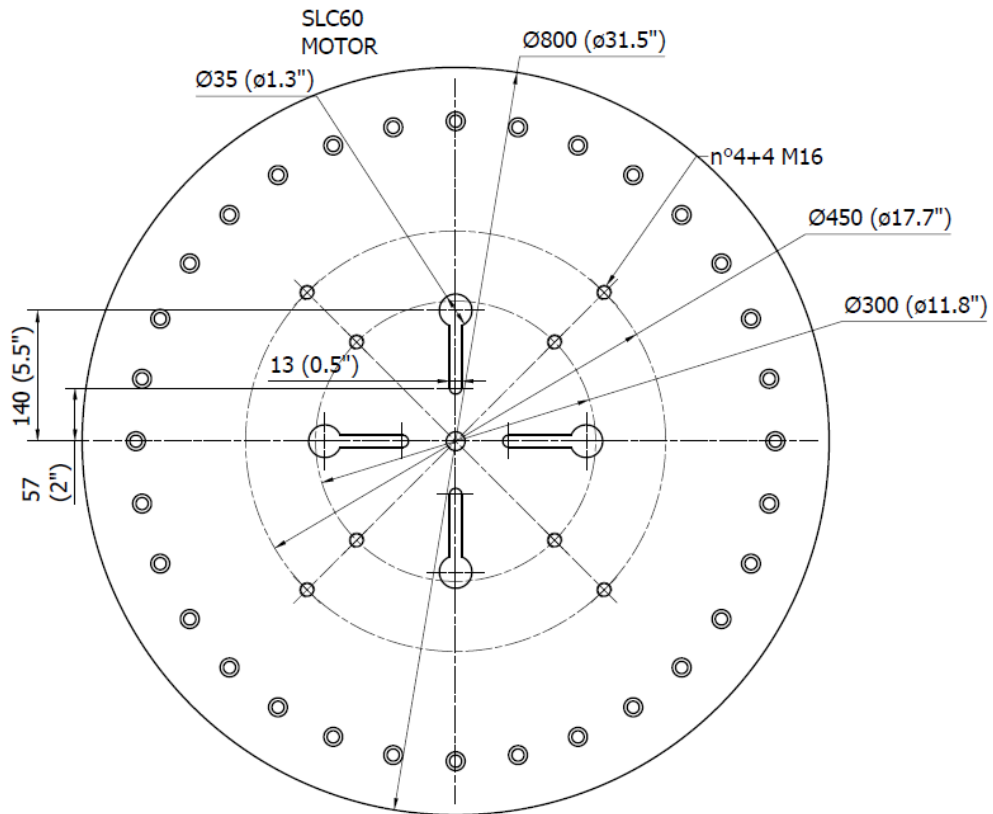

Threaded hole depth: 25mm (1 in)

**SLC 100 – SLC 120 – SLC 150 – SLC 200**

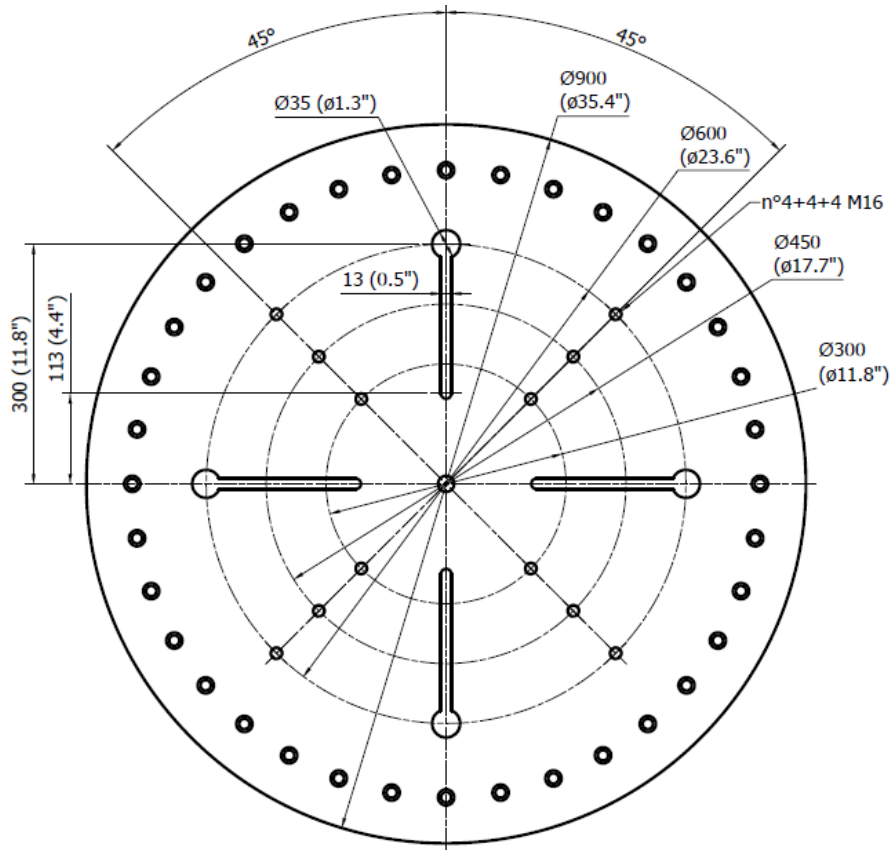

**SLC 250**

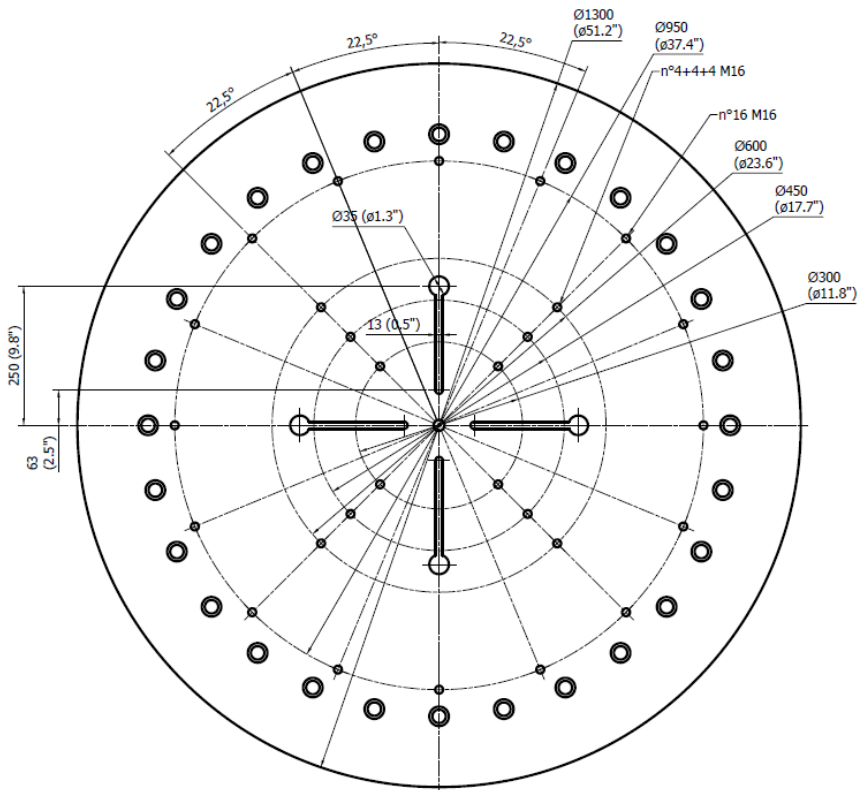

**Threaded hole depth: 25mm (1 in)**

**SLC 300**

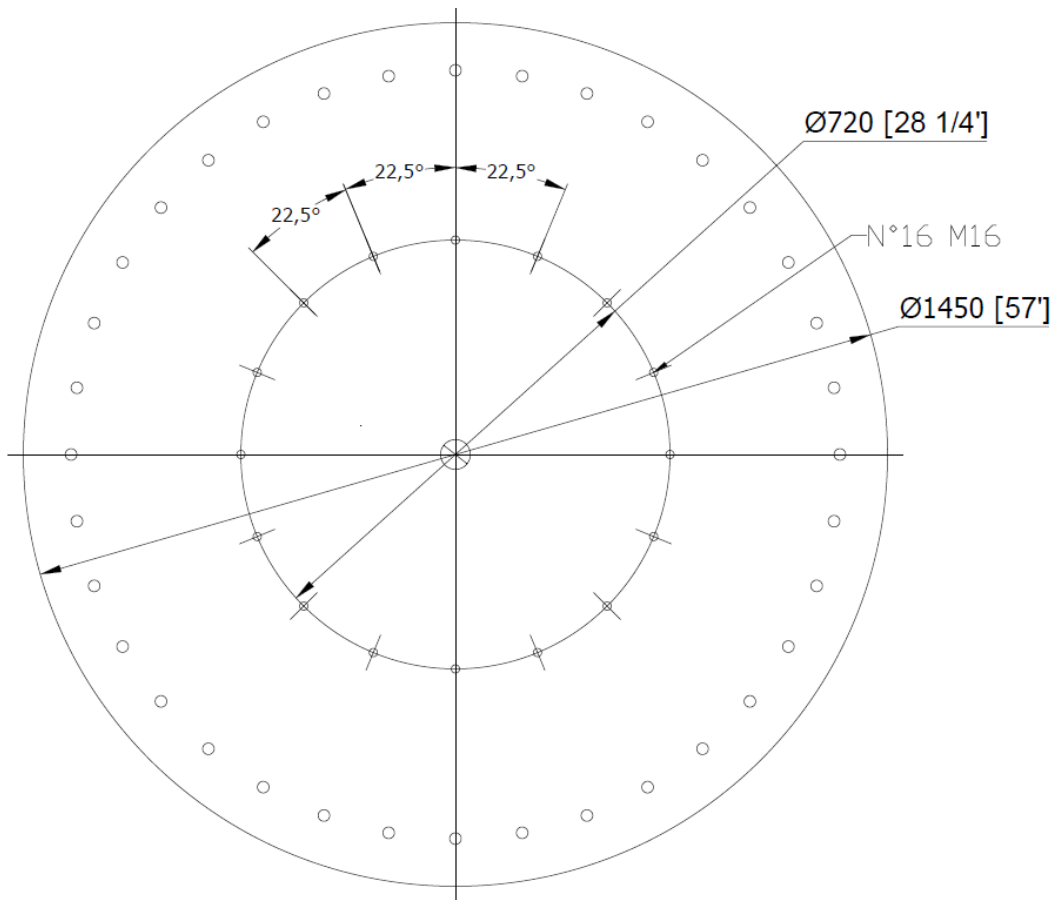

**Threaded hole depth: 25mm (1 in)**

## A.3 - TECHNICAL FEATURES, SAFETY PRECAUTIONS AND WORKING LIMITS

### A.3.1 – TECHNICAL FEATURES

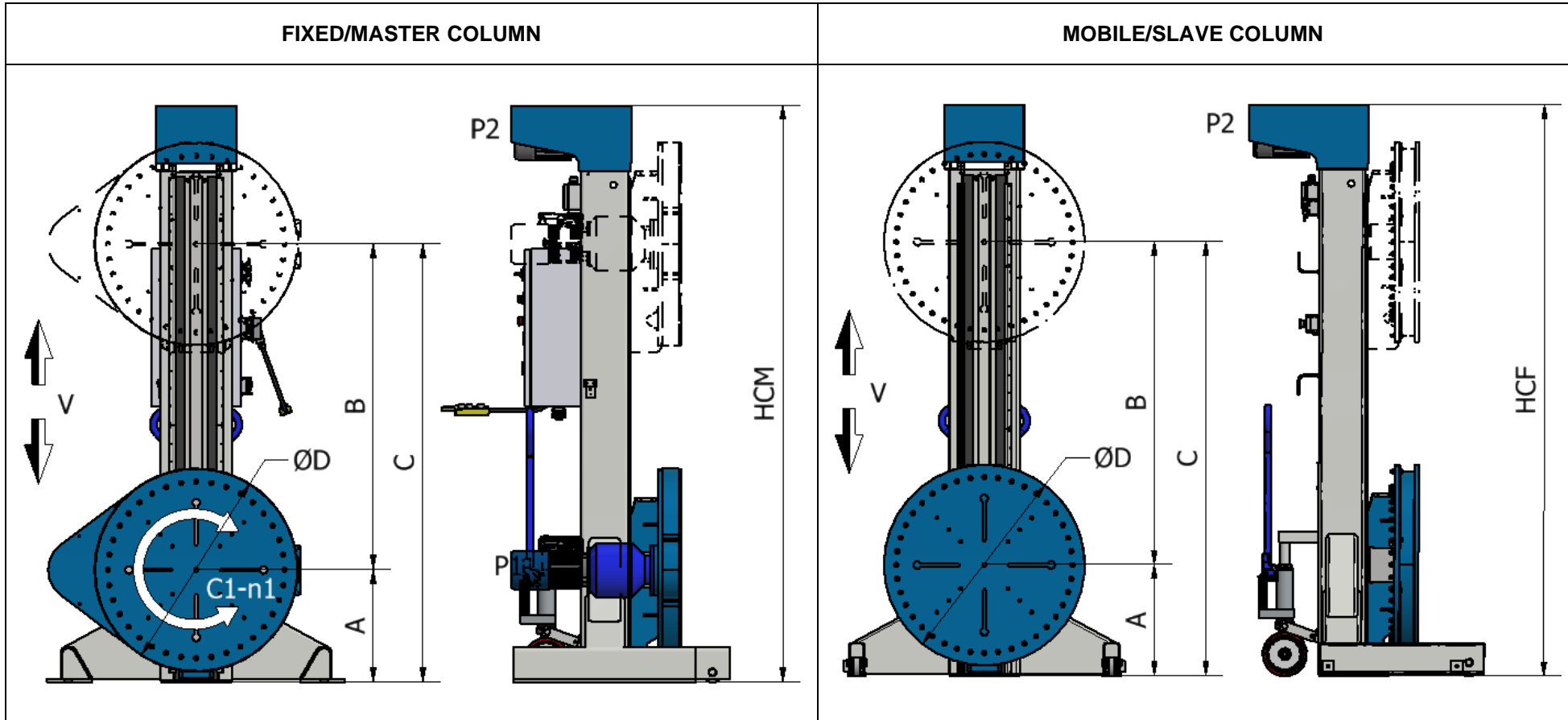

Model	Loading Capacity	Max Torque	Table Rotation Speed	Elevation Speed	Min. Height	Stroke	Max Height	Table Ø	Master Column Height	Master column Weight	Master column Weight (hybrid)	Slave Column Height	Slave column Weight	Rotation motor power	Lifting Motor Power
	F [kg]	C1 [N·m]	n1 [rpm]	V [mm/min]	A [mm]	B [mm]	C [mm]	D [mm]	HCM [mm]	[kg]	[kg]	HCF [mm]	[kg]	P1 [kW]	P2 x2 [kW]
SLC 20	2.000	3.000	1	560	350	1450	1800	600	2505	602	637	2505	447	0,75	1,85
SLC 40	4.000	3.500	1	560	350	1550	1900	600	2505	519	554	2505	490	0,55	1,85
SLC 50	5.000	4.000	0,9	560	400	1550	1950	750	2505	580	616	2505	550	0,55	1,85
SLC 60	6.000	5.500	0,75	560	450	1500	1950	800	2505	615	651	2505	569	0,55	1,85
SLC 100	10.000	7.500	1,1	650	500	1450	1950	900	2595	796	830	2592	712	1,1	2,2
SLC 120	12.000	10.000	1,1	650	550	1400	1950	1000	2595	852	885	2592	770	1,5	3
SLC 150	15.000	15.000	1,3	650	550	1450	2000	1000	2680	964	1000	2677	880	2,2	3
SLC 200	20.000	22.000	0,9	560	550	1300	1850	1000	3100	1200	===	3100	1100	2,2	3,7
SLC 250	25.000	25.000	0,9	470	700	1150	1850	1300	3100	1300	===	3100	1200	3	4
SLC 300	30.000	35.000	0,75	290	750	1250	2000	1450	3300	1400	===	3300	1300	3	4



**A.3.2 – FACSIMILE OF THE MACHINE PLATES**

<p>NAMEPLATE OF CONTROL UNIT</p>	<p><b>SIDEROS MACHINERY</b> Via Ugo Foscolo 16/18, Podenzano (PC) - ITALY</p> <table border="1" style="width: 100%; border-collapse: collapse;"> <tr> <td style="width: 50%;">S/N</td> <td style="width: 50%;">Year of constr.</td> </tr> <tr> <td>Total nominal Power Kw</td> <td>Volt/Hz.</td> </tr> <tr> <td>Weight kg</td> <td>Total capacity</td> </tr> </table> <table border="1" style="width: 100%; border-collapse: collapse;"> <thead> <tr> <th style="width: 50%;">MASTER COLUMN (MASTER)</th> <th style="width: 50%;">SECONDARY COLUMN(SLAVE)</th> </tr> </thead> <tbody> <tr> <td>Nominal Power Kw</td> <td>Nominal Power Kw</td> </tr> <tr> <td>Capacity Kg</td> <td>Capacity Kg</td> </tr> </tbody> </table> <p style="text-align: center; font-size: 2em;">CE</p> <p style="text-align: right;">Mod. ....</p>	S/N	Year of constr.	Total nominal Power Kw	Volt/Hz.	Weight kg	Total capacity	MASTER COLUMN (MASTER)	SECONDARY COLUMN(SLAVE)	Nominal Power Kw	Nominal Power Kw	Capacity Kg	Capacity Kg
S/N	Year of constr.												
Total nominal Power Kw	Volt/Hz.												
Weight kg	Total capacity												
MASTER COLUMN (MASTER)	SECONDARY COLUMN(SLAVE)												
Nominal Power Kw	Nominal Power Kw												
Capacity Kg	Capacity Kg												

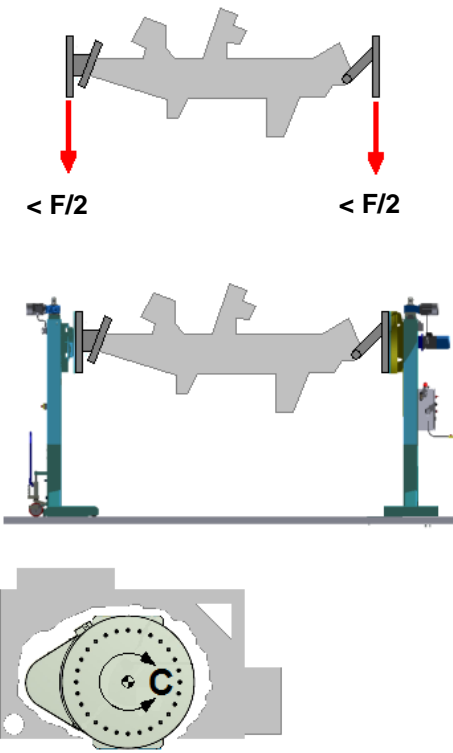
<p><b>NAMEPLATE OF COLUMNS</b></p>							
<p><b>SIDEROS MACHINERY</b> Via Ugo Foscolo 16/18, Podenzano (PC) - ITALY</p> <table border="1" style="width: 100%; border-collapse: collapse;"> <tr> <td style="width: 50%;">S/N.</td> <td style="width: 50%;">Year of constr.</td> </tr> <tr> <td>Nominal Power Kw</td> <td>Volt</td> </tr> <tr> <td>Weight kg</td> <td>Capacity kg</td> </tr> </table> <p style="text-align: center; font-size: 2em;">CE</p> <p style="text-align: right;">Mod. ....</p>		S/N.	Year of constr.	Nominal Power Kw	Volt	Weight kg	Capacity kg
S/N.	Year of constr.						
Nominal Power Kw	Volt						
Weight kg	Capacity kg						

NAMEPLATE OF PROHIBITIONS	LOAD SCHEME
 <p>DO NOT REMOVE THE SAFETY DEVICES AT MACHINE IN MOTION</p>	
 <p>IT'S FORBIDDEN TO WORK ON DEVICES IN MOTION</p>	

### A.3.3 – OBLIGATIONS

- The installation must be definitely carried out by qualified personnel
- Before starting with any operations, define the safety area in which the rotation of frame is possible.
- Once identified the safety area (so the minimum height above which the rotation of frame is guaranteed), proceed with cutting the security plate (yellow colour) screwed on the front of the slave column at a height (measured from the ground) equal to the minimum height
- The control of the positioner must be carried out by qualified personnel that have birthday 18 years old at least
- To use the machine, employ operators with proven ability, adequately trained
- **It's mandatory to check that the loading weight is lower or equal to the total capacity (F) and that the load for each column doesn't exceed half of the maximum load (F/2)**
- **Frames and workpieces mounted on columns must be positioned so that the rotation axis is approximately barycentric in regard to the workpiece, in order to limit the torque required for rotation. The torque necessary for the rotation of the workpiece must not exceed the maximum limit (C)**
- Jigs have to be properly screwed according to the type of fastening of jig itself (See *Part A chap. 2.1 – General drawing*)
- It is mandatory to observe ALWAYS the load during lifting and lowering.
- It's mandatory, before each movement with the positioner, check if column were lowered after an eventual transfer of them.
- It's mandatory, before each movement with the positioner, to check if the workpiece is properly fixed at flanges on the master and on the slave columns.
- It's mandatory, before each movement with the positioner, to view the status of the warning lights on the control unit (BLUE light)
- It's mandatory, during the use of pendant remote-control unit, to ensure that no operator or equipment are near the workpiece or in contact with it.
- It's mandatory that the workpiece rotation by pendant remote-control unit is carried out by personnel informed about risks that operation entails: the rotation of the welding workpiece below the safety area can cause the collision of it with the floor and/or other equipment or people nearby
- It is mandatory to keep the dangerous zone clear during the use of the positioner and to assert oneself that these regulations are enforced.
- It's mandatory that keys delivered by Sideros Machinery to work with the control unit are entrusted by the Responsible of machine or maintenance.

- It is mandatory to respect the given dates for the inspection and lubrication services.
- Use only original spare parts, shown by the Manufacturer.
- It is mandatory to stop the positioner immediately if irregularities occur and refer to section B (PROBLEMS AND SOLUTIONS)
- It's mandatory to ensure that all parts of the connection system to the mass cable of welding machine, assembled on both master carriage and on the slave one, are properly fixed together.
- It's mandatory to ensure that the load, generated from the welding system in use, do not exceed the maximum capacity of the positioner.
- It's mandatory to ensure that features of the electric installation of the warehouse comply with what mentioned at chapter **5.3**
- It's mandatory to use screws M16 of class 8.8 at 190Nm, in order to fix the interfaces on the flange
- It is mandatory to verify that the concrete is type C20/25-  $f_{ckcube}=25N/mm^2$  . The minimum thickness must be: 160mm for fixing screws M12 (models SLC20-120); 200mm for fixing screws M16 (models SLC150-300)
- The study of fixing of the piece to be produced to the positioner is end user responsibility and must be within the limits of use indicated in this manual. Sideros is not responsible in case of incorrect fixing of the piece.
- It is mandatory to install and use the positioner only on horizontal surfaces (tolerance 1mm x 1m)







#### A.3.4 - PROHIBITIONS













- It is prohibited to climb or to stay on the supported unit or on the lifted workpiece.
- It is prohibited people presence near the service area, during the ascent, the descent and the rotating movement of the workpiece.
- During maintenance, it is the operator's responsibility of making sure that nobody is near the positioner.
- It's prohibited to place the workpiece on the positioner during maintenance service.
- It is prohibited to use the positioner for purposes different to those for which it has been designed and manufactured.
- It's prohibited work with the positioner if columns weren't lowered after eventual transfers.
- It's prohibited the use of the pendant remote-control unit for the rotation to people who weren't properly trained about risks, limits and dangers that operation can entail: by operating in this way, in fact, the anti-collision control is automatically excluded and it is therefore necessary, during rotation, to carefully check and visually monitor in order to avoid any collisions with the floor and / or equipment and / or people nearby.  
During these operations, the rotating movement of the workpiece is combined with an acoustic and bright signal
- It's prohibited to place welding frames that force each column to a load superior than "F/2"
- It's prohibited to place frames with geometrical configuration that require, for their rotation, a torque superior than "C".
- It's prohibited the use of the ergonomic positioner for welding operations if the features of the electric installation of the warehouse do not comply with what is mentioned on chapter **5.3**
- It's prohibited the use of the ergonomic positioner with connection system to the mass cable of welding machines if it has not been verified that all electric and mechanical interconnection system are properly fixed.
- It's prohibited the use of the ergonomic positioner for welding operations if the load generated from the used machines exceeds the maximum capacity of the positioner.

### A.3.5 – RESIDUAL RISKS

As far as possible, actions have been adopted to try to eliminate risks for the workers and / or limit /reduce risks arising from dangers not completely eliminable at the source.

Nevertheless, although all adopted precautions, remain on the lift some residual risks, eliminable or reducible by the following preventions activities.

RISKS DURING THE USE		
DANGER	OBLIGATION / PREVENTION	PROHIBITION / WARNING
 <p>Risk of dangers of crushing caused to the contact with mechanical devices and moving parts.</p>	 <p>Operator in charge of use has to follow the prescriptions in that instructions manual to obtain a better safety.</p>	 <p>It's prohibited to lift loads while people pass through the maneuver area or through the trajectory of the moving frame.</p>
 <p>Risk of dangers of fouling caused to the contact with mechanical devices and moving parts.</p>	  <p>Obligation to use gloves and protective shoes during the load movement.</p>	

RISKS DURING MAINTENANCE		
DANGER	OBLIGATION / PREVENTION	PROHIBITION / WARNING
 <p>Risk of dangers of electrocution during maintenance phases, in case of contact with electric devices without the disconnection of the electric power.</p>	  <p>Entrust electric maintenance operations to qualified personnel. Carry out verifications of electrical devices as described on the instructions manual.</p>	  <p>It is prohibited to act on electrical devices without disconnecting the electric power from the machine.</p>
 <p>Risk of dangers of fouling and / or crushing in case of contact with moving parts during maintenance phases.</p>	   <p>Entrust the maintenance phases only to specialized technicians, Obligation to use gloves and protective shoes.</p>	 <p>Attention! Exposure to moving parts can originate dangerous situations. It's prohibited to re-activate the lift if the protections have not been reassembled.</p>
	<p><b>ELECTRICAL TECHNICIAN</b> Specialized operators capable to work in standard conditions for electrical, regulation, maintenance and replacement interventions.</p>	
	<p><b>MECHANICAL TECHNICIAN</b> Specialized technician, trained and / or charged by Sideros Machinery, authorized in carrying out extraordinary and complex mechanical operations.</p>	

## STRAY CURRENTS

An incorrect use of the machine or a damage can lead to the dispersion of stray currents they can run along the metal structure of the machine with a serious risk to person's health.

In this regard, the machine has a grounding system that discharges this current:

- the user must connect the machine to a power supply system equipped with a protection device that automatically intervenes in case of failure. Our protection systems refer to the TN overcurrent protection system.
- the user must connect the machine to a power supply system equipped with overcurrent protection, with adequate intervention current to protect the power supply conductors.
- the user must check at each use that the plug is correctly inserted.

## INVERTER

Inside the electric panel there is an inverter that controls rotation movements of the flange.

In this component, residual current can be accumulated even after shutdown. In addition, some surfaces may present high temperature danger. Before opening the electric panel, it is necessary to wait until the remaining currents have discharged, and that hot surfaces have cooled down.



### A.3.6 – IMPROPER USAGE

It is prohibited to use the SIDEROS MACHINERY ergonomic positioner model SLC for purposes different from those indicated in this manual.

Improper use of the ergonomic positioner can hold no guarantee for the machine.

According to what has been written on this instruction manual, SIDEROS MACHINERY declines each responsibility in case of:

- Use of the machine opposed to national safety laws
- Erroneous arrangement of the building site and of structures in which lift will be placed;
- Lacks of tension or of electric power and / or of others energizing sources;
- Lacking or erroneous compliance of the supplied instructions on this manual;
- Unauthorized modification on the lift;
- Use of the lift from workers not properly trained or not apt.
- Use of devices for welding that do not comply with the latest directive.
- Load on connection system of the mass greater than the maximum load allowed.

### IMPROPER USE OF MOTORS

The electric motors in the machine, i.e. the two up/down motors and the rotation motor, have been designed and sized for intermittent use for a proportion of 70% in use and 30% at rest.

It should also be noted that the rotation motor, controlled by the inverter, has its maximum efficiency with the potentiometer at maximum. It is therefore recommended to use the positioner with reduced rotation speed only in the short term. The value of the potentiometer is directly proportional to the rotation speed of the fan and in the case of continuous use at reduced speed, the motor overheats.

**The modification of the rotation speed by means of a potentiometer is allowed only to authorized and qualified personnel.**

### A.3.7 – NOISES AND VIBRATIONS

The ergonomic positioner model SLC has been projected and manufactured to be compatible with current technical advancements, the reducing of the aerial noises and vibrations emitted by the column and central unit during the lifting and descending phase.

The level of the acoustic pressure results inferior to 70 dB (A).

### A.3.8 – SUITABLE ENVIRONMENTAL CONDITIONS FOR THE USAGE OF THE POSITIONER

**Floor:** Ergonomic positioner has to be installed on horizontal flat floor with characteristic resistance of  $R_{ck}=30 \text{ N/mm}^2$  e  $\sigma_{c adm} = 70 \text{ daN/cm}^2$  (for ex.: smooth concrete). To have a correct fastening of anchoring bolts, floor has to have a minimum thickness not less than:

SLC20	SLC40	SLC50	SLC60	SLC100	SLC120	SLC150	SLC200	SLC250	SLC300
160 mm	160 mm	160 mm	160 mm	160 mm	160 mm	200 mm	200 mm	200 mm	200 mm

**Features of the electric installation on warehouse:** Functioning of the ergonomic positioner with interconnection system to the mass cable of the welding machines is allowed only if the electric installation of the warehouse has a ground impedance equal or superior than 2 Ohm. This value has been measured with estimated current of short circuit of 115 A and tension of contact equal to 25V.

For a tension of contact of 50V and estimated current of short circuit of 230 A, ground impedance has to be equal to 1 Ohm to have the correct functioning of the positioner.

The lift must be installed following the instructions provided to the user on a case-by-case basis.

**Necessary surface for the lifting and usage of the equipment:** The necessary surface for the installation, use, maintenance operation service of the vehicle must guarantee the following free space:

- A free space at front and back side of at least 1m from column's crammed shape.
- A free space at lateral side of at least 2 m from column's crammed shape.

**Lightning:** The working area must have adequate lightning (at least equal to 300 lux.).

**Indoor installation:** The lift cannot be used in a dangerous explosive environment and it must comply with fire safety measures required by current regulations.

**Outdoor installation:** Outdoor use of the ergonomic positioner is not allowed.

## A.4 – POSITIONING AND INSTALLATION

### A.4.1 – LIFTING AND TRANSFERRING OF THE MACHINE

In order to lift the columns, insert a steel pivot (20 mm in diameter, 800 mm in length) on the backside tube of the column. Therefore, use textile fibre rods and a suitable lifting device, adequate to the weight of the single column indicated in the table (page 6) or on the shaft of each column. If any, use welded ears on the top of the column using a lifting system and straps sized in relation to the weight to carry out the handling.



- All lifting operations must be carried out by qualified personnel aware of current safety regulations.
- Lifting carried out without taking necessary precautions involve risks for people and things.



### A.4.2 - POSITIONING AND INSTALLATION OF THE MACHINE IN THE WORKING AREA



**Attention:** The mouveable column is not equipped with any braking device, therefore it is strictly forbidden to move them on slopes.

The lifting equipment must be used only on sturdy and flat concrete floors of adequate load-bearing capacity. To move the SLAVE column proceed as follows: lift the column by using the rudder of the hydraulic jack with sunked control lever (*lift*) (see dwg A), and act on the rudder itself to guide them. The lifter must only be pushed for its normal movement (see drawing B). If it is impossible to control the movement due to irregular floor surfaces, the lifting equipment can be stopped immediately by lowering the column by activating the lever in the upper position (*descent*), (see dwg A), located on the rudder of the jack.

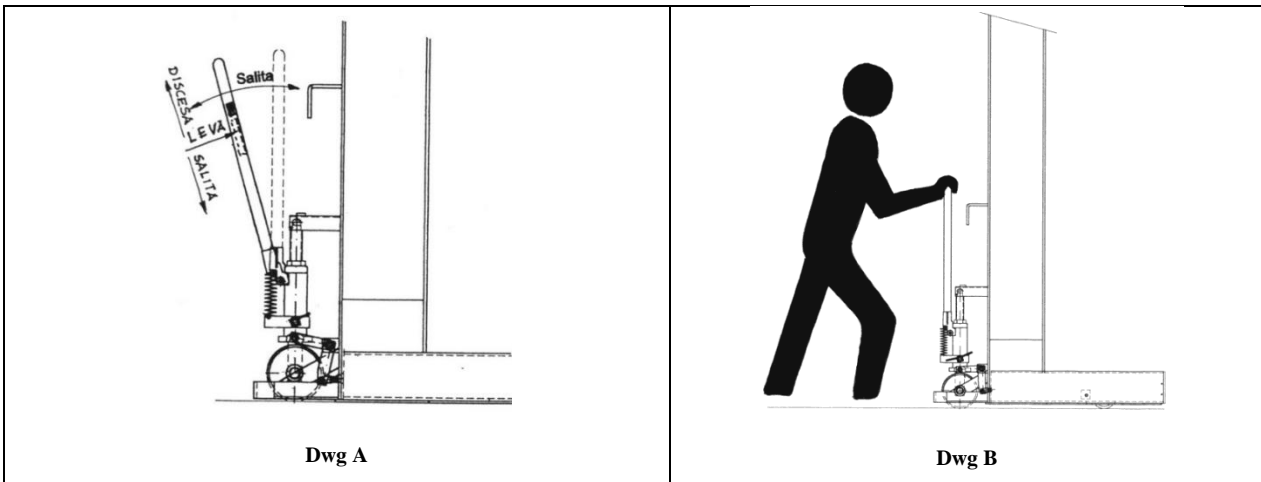

- The positioning of master and slave columns has to be realized according to the workpiece to lift. As shown on the following scheme, identify the variable B given by the workpiece to lift and place the columns according to related levels.
- Once the columns are placed in the correct position, lower them by using the rudder of the hydraulic jack, checking that the column is properly leant on the ground. In addition, the slave column can be fixed.

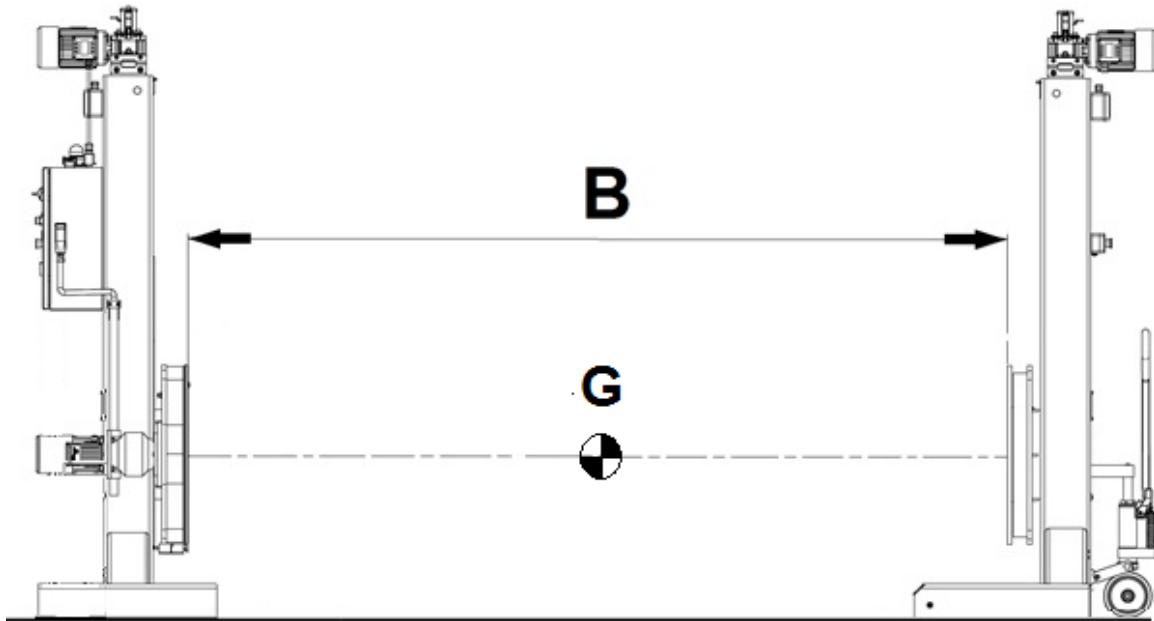

Positioning of the columns according to length "B" of the workpiece

Furthermore, ensure that columns are perfectly aligned to avoid the imbalance of the load.

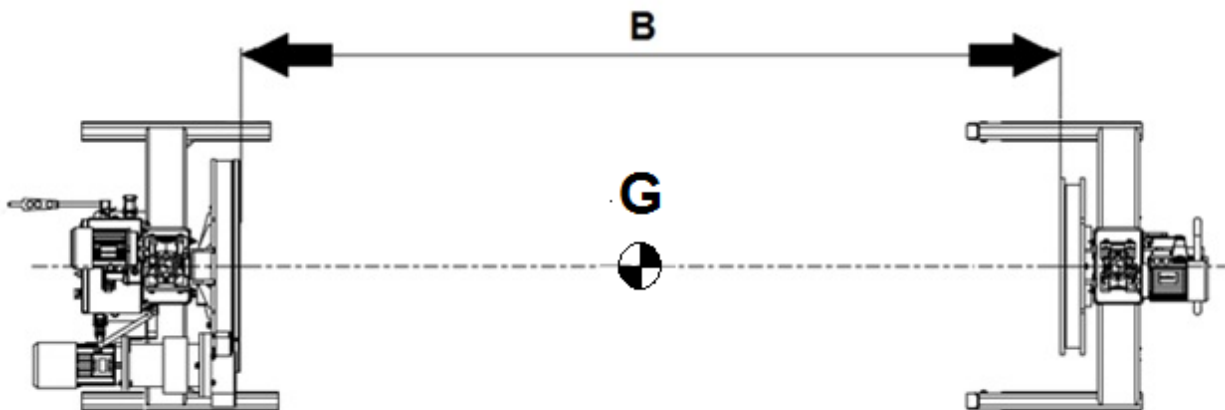

For the positioning and the fastening of fixed master column, follow those instructions:

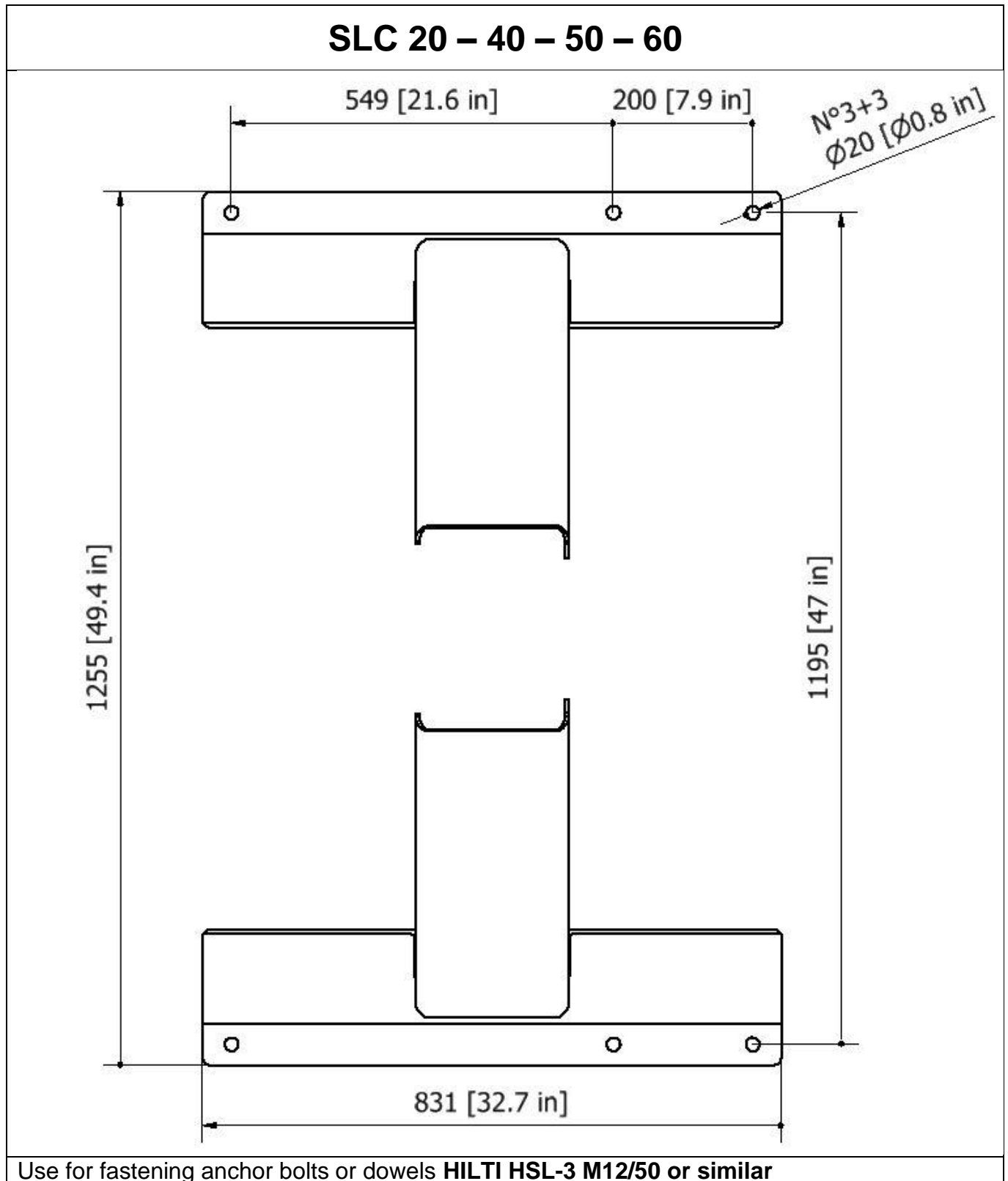

## SLC 100 – 120

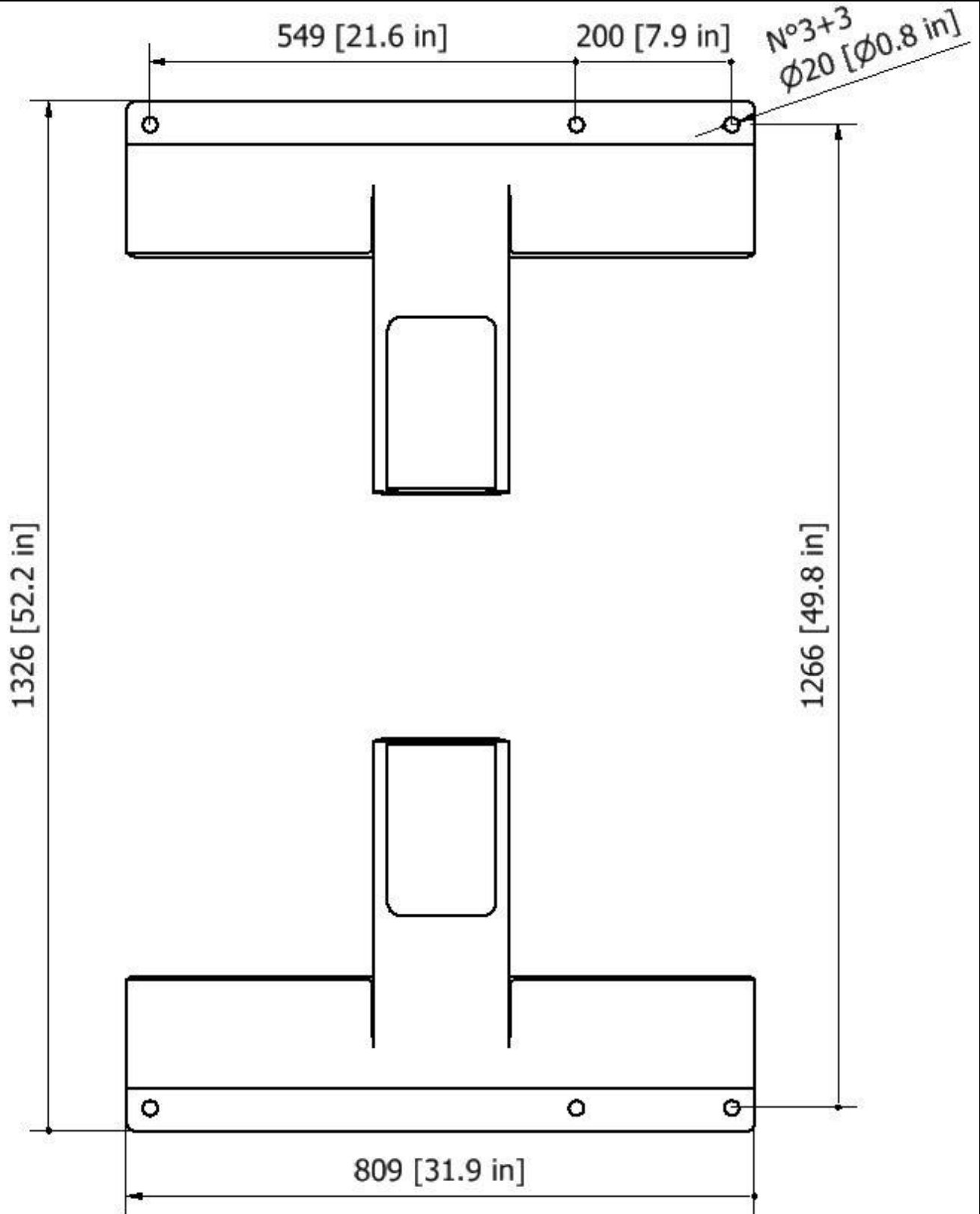

Use for fastening anchor bolts or dowels **HILTI HSL-3 M12/50** or similar

## SLC 150

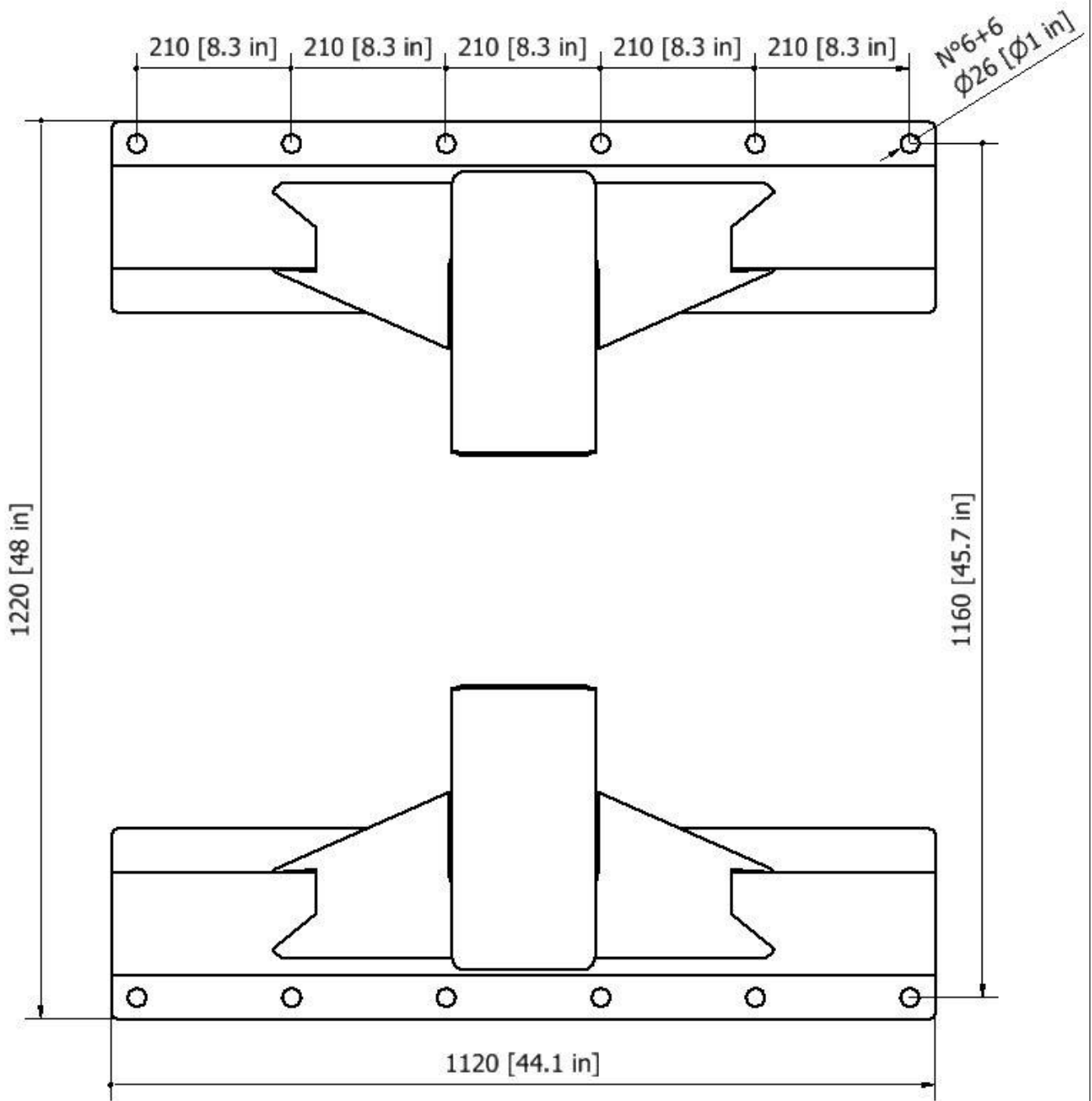

Use for fastening anchor bolts or dowels **HILTI HSL-3 M16/50 or similar**

## SLC 200

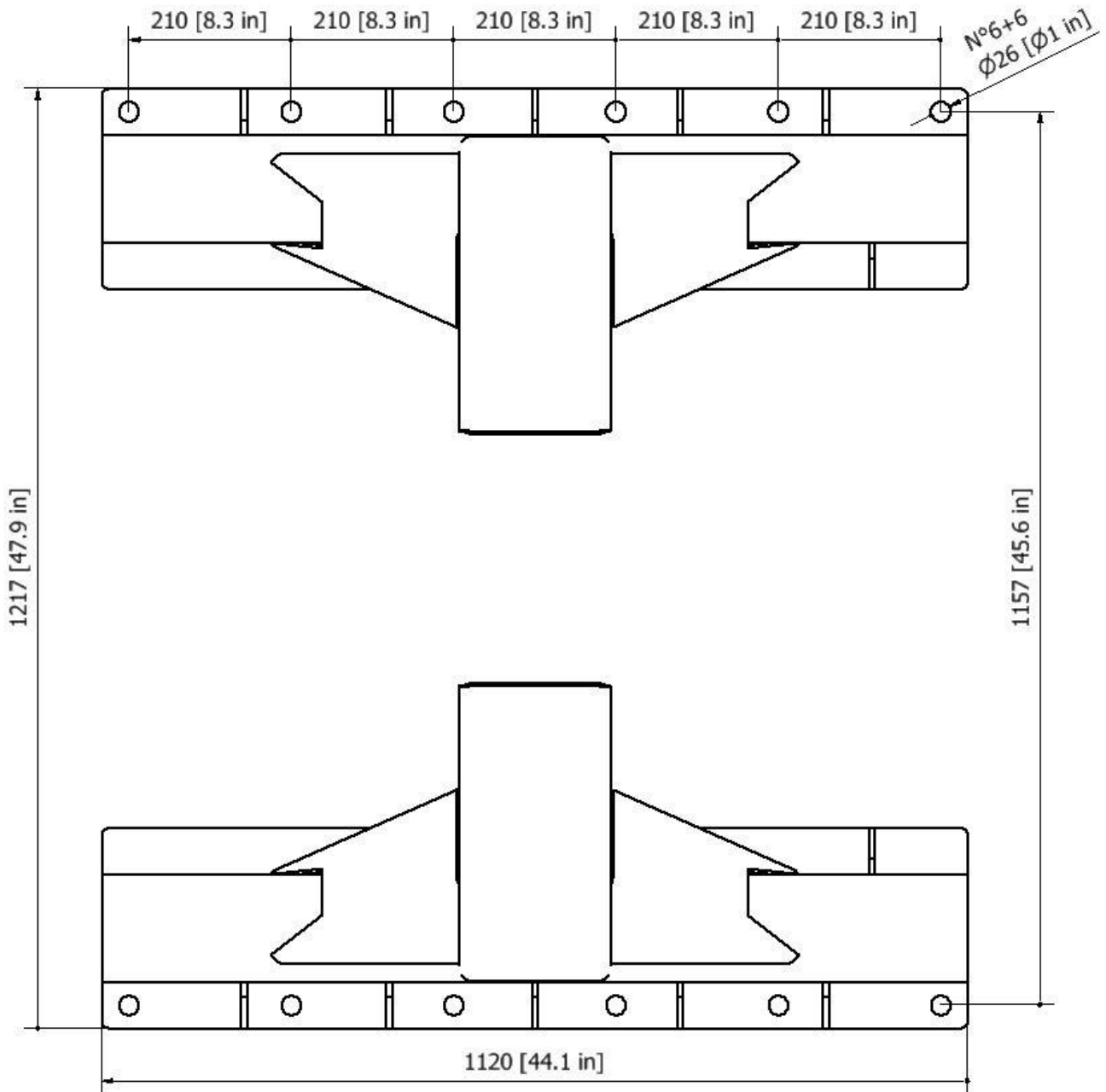

Use for fastening anchor bolts or dowels **HILTI HSL-3 M16/50** or similar

## SLC 250 – 300

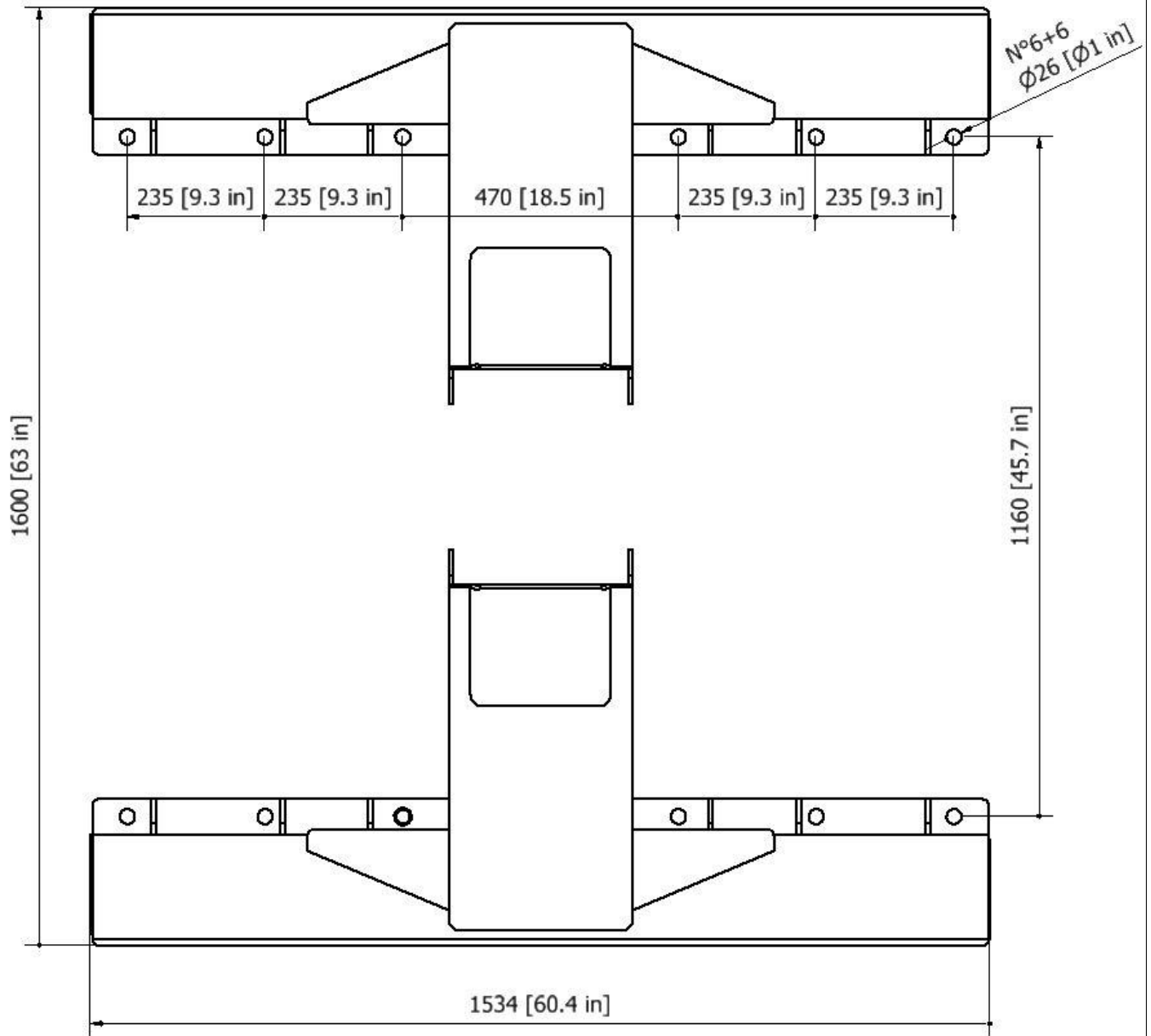

Use for fastening anchor bolts or dowels **HILTI HSL-3 M16/50 or similar**

### A.4.3 – ELECTRICAL CONNECTIONS

1. The connection to the network power must take place by means of a general magneto thermal switch and a differential switch. The electric panel has to be in the warehouse where the positioner will be placed according to where the positioner is installed and according to the latest directives.
2. Columns are supplied completely pre-wired, equipped with fast plugs with safety mechanical block. The control unit is composed of:
  - Plug at 10 poles for the connection to the cable of MASTER column
  - Plug at 10 poles for the connection to the cable of SLAVE column
  - Plug at 10 poles for the connection to the device of the ANVIL of the MASTER column
  - Plug at 16 poles for the connection of the pendant remote-control unit used for the rotations below the safety range
  - Plug at 6 poles for the connection of the foot pedal control (optional)

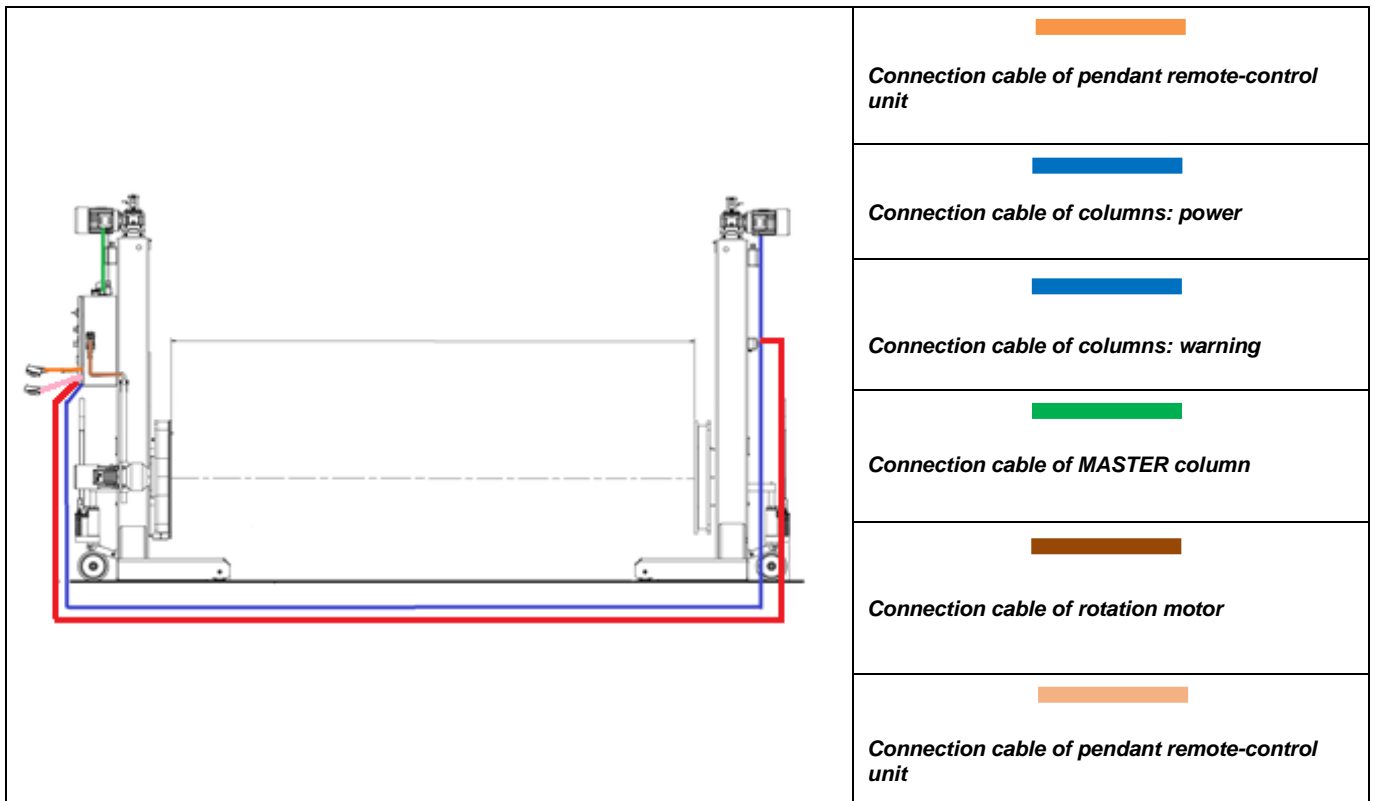

#### A.4.3.1 - ELECTRICAL CONNECTION OF THE MASS SYSTEM FOR WELDING MACHINE (OPTIONAL)

The ergonomic positioner can be equipped with interconnection cables for the connection with the mass cable placed on welding machines. On that way, it is possible to carry out welds of frames placed on the ergonomic positioners avoiding an interference between the workpiece in rotation or in movement and the mass cable of the welding machine.

The interconnection cable and devices placed on each column guarantee the electric continuity between the frame and the welding machine, so that the closure of the electric arc during the welding phases.

For a better conductivity and distribution of electric loads, interconnection cables are placed on both columns. Indeed, if the frame is of high dimensions, the connection of the mass cable to both columns guarantees the stability of the electric arc during welding phase. In any case, do not exceed the load supported by those devices.

In picture **A** is shown the installation of the interconnection cable system (1) and of sliding electric masses placed on anvils of the ergonomic positioner. In picture **C** is shown a detail of the sliding electric masses and the coupling with a conductor pipe made of steel electrically integral with the flange. In picture **B** is shown the traction system of metallic braid and the interconnection cable for the connection with mass cable of the welding machine.

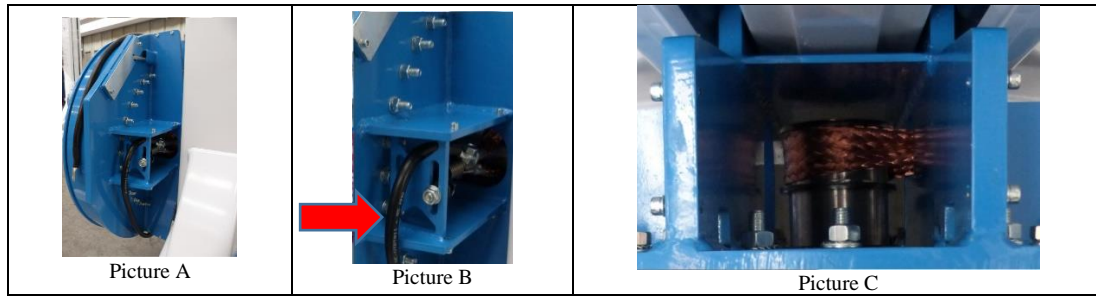

When is necessary to do welding operations on the workpiece fixed to the ergonomic positioner, it has to:

- Verify that the workpiece is correctly fixed on flanges of master and slave carriages: indeed, electrical continuity is guaranteed by the contact of fastening screw and threaded holes on flanges. That's why is necessary to clean those holes from impurities that can inhibit the correct transfer of current.
- Verify that the interconnection cable at the mass cable of welding machine placed on each column is properly connected to the devices placed on each carriage.
- Connect the mass cable of the welding machine to both interconnection cables of master and slave columns. In particular, if the frame has high dimension, the connection with both interconnection cables guarantees a better closure of the electric arc during welding phases.

Now it is possible to carry out the welding of frame lifted by the ergonomic positioner. Furthermore, it is possible to turn and move the workpiece keeping connected the mass cable of the welding machine to the two interconnection cables of columns, obtaining advantages in terms of time saving and convenience in the use of the positioner.

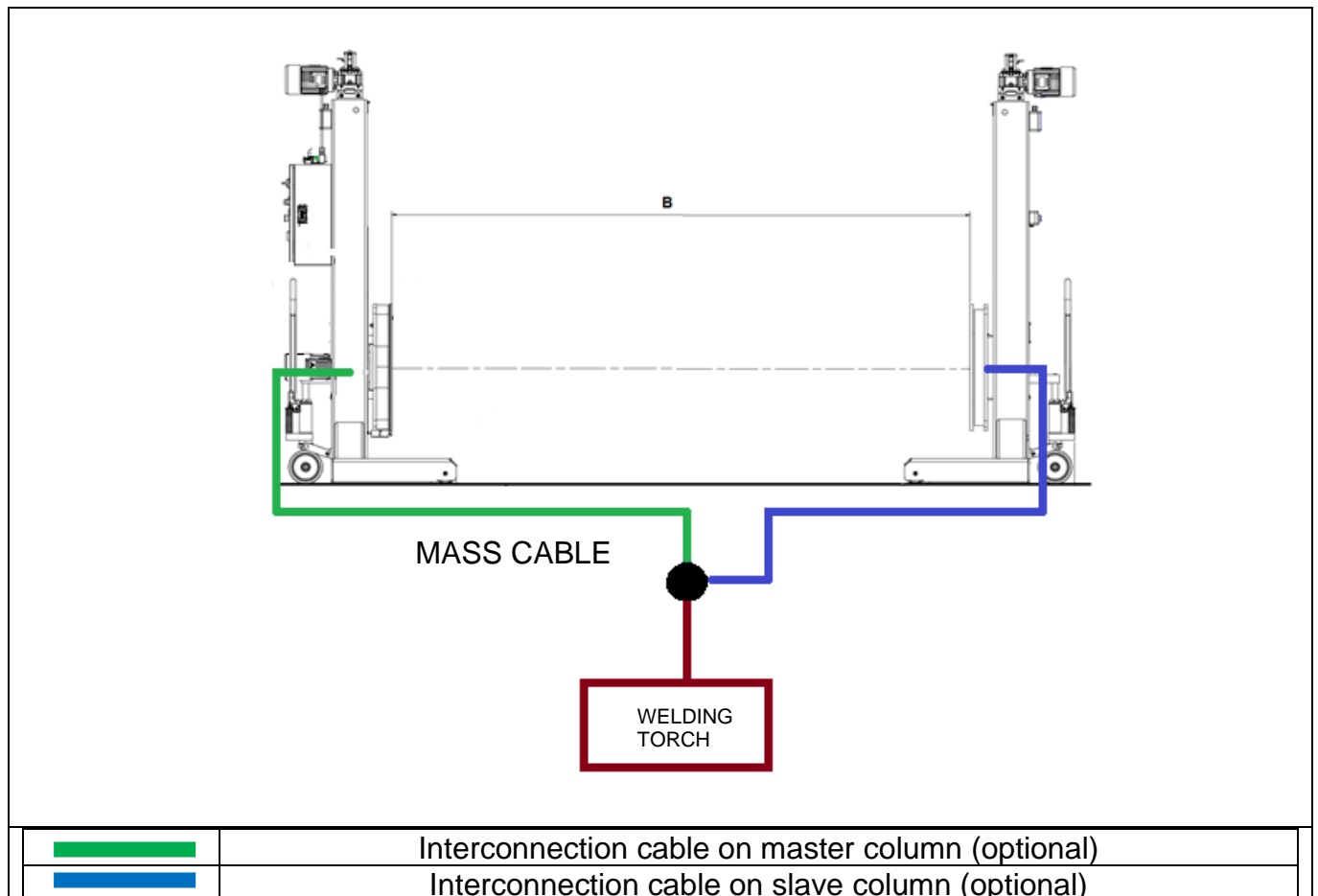

### **A.5 – DISASSEMBLING – SHIFTING – STORING**

- **Disassembling:** Once work is completed, all connectors must be disconnected from the computerized control unit and wrap around the cable of each column in its proper cable hook.
- **Shifting:** Disconnect all interconnected cables with the computerized control unit (both the electrical supply cable and the cables of the computerized control unit connected to the columns).  
Wrap on columns its own cables, using the specific cable holler hooks.
- **Storing:** Return the columns and the control unit back to a covered and dry place.

### **A.6 – DEMOLITION – WASTE DISPOSAL**

At the end of the operational lifetime of the lifting equipment the owner must demolish and scrap it in compliance with current standards, handing the various components over to authorize disposal centers.

# PART B

## MAINTENANCE

### B.1 – PERIODIC MAINTENANCE

### B.2 - CHECKS

### B.3 - PROBLEMS AND SOLUTIONS



- ALL LIFTING JOBS MUST BE PERFORMED BY SKILLED PERSONNEL AWARE OF CURRENT SAFETY STANDARDS.
- LIFTING OPERATIONS PERFORMED WITHOUT PRECAUTIONS INVOLVE RISKS FOR PEOPLE AND OBJECTS



The non-respect of following indication relieves the manufacturer SIDEROS MACHINERY from any responsibility.

- Before operating on the lift, read carefully the instruction and operation manual points **A.3.2 OBLIGATIONS – A.3.3 PROHIBITIONS – A.3.4 IMPROPER USE, part A.**
- During operations, which do not require electric power, it is mandatory to eliminate all kind of electrical connection, which may create danger of electrocution.
- The equipment used for the maintenance must be perfectly efficient and must comply with the current safety norms.
- It is compulsory to respect the modalities and the frequencies of the maintenance operations.
- It is mandatory to substitute or replace all components, which may result broken, faulty, damaged, overused or not correctly working.
- After each maintenance it is compulsory to fill in completely and correctly the **CONTROL REGISTER (Part C) PERIODICAL CHECKS.**

The equipment must be kept in a perfectly efficient state by observing normal measures of good preservation.

## B.1 - PERIODIC MAINTENANCE (OPERATIONS TO CARRY OUT EVERY 3 MONTHS)

In addition to the hereafter mentioned instructions, please carry out all the verification pointed out on paragraph 6 Part C, by paying attention on compiling the dedicated register.

**STRUCTURES AND MECHANISMS:** lubrication of the screw, ball bearings, of the parts at sight or subjected to movement, check of the column setting, check of tightening, etc.

- With the forks at height **0 (zero)**, remove the protection and lubricate the trapezoidal spindle lying down, by using a brush, a grease veil and eliminate the surplus. Use ONLY teflon-based grease or lithium soaps. SIDEROS MACHINERY suggests Klüberplex BEM 41-132. For any need, contact local Technical Service Centre SIDEROS MACHINERY: ☎: +39 0523 524066 -- E-Mail: support@siderosengineering.com



- Lubricate with specific grease all bearings, with particular care to the thrust bearing mounted under the gearbox.



- Lubricate all parts at sight not painted or protected with surface treatments, such us: sliding guides and side walls inside the column structure (sliding slopes of trolley wheels).



- Remove impurities deposited inside covers of closure placed on flange.

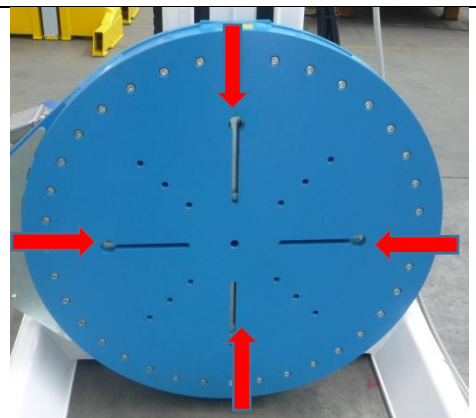

- Lubricate the rotation slewing bearing placed on the slave column by removing the tightening elements from the plate, using adequate lifting systems. Also remove the toothed-pinion bearing protection cover placed on the motor trolley to allow adequate lubrication of the toothed-pinion bearing system. Then, follow with the application of grease (**kluberplex BEM41-132**) with a manual or pneumatic greaser by using the dedicated greaser placed on bearings. Rotate the slewing bearing to have a uniform distribution of grease. Once the lubricant operations of the slave slewing bearing have been ended, re-positioning the slave flange and clamp the fastening screws with **a tightening torque not less than 75Nm**. For this operation, use a dedicated dynamometric key.

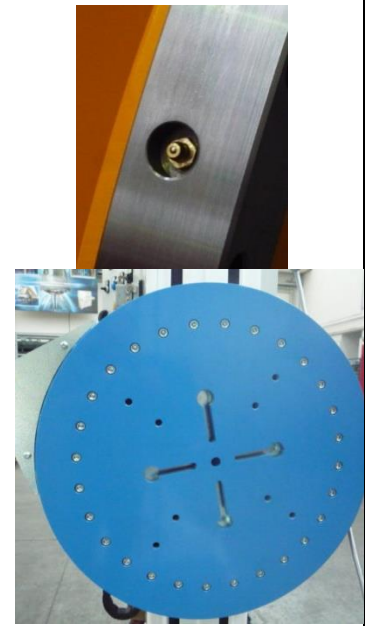

### LUBRICATION SLC 20

- Lubricate the bearings both on the master and slave columns carriage. To reach the greasing points of each bearing it is necessary to:
  - Remove metal protections of the carriage (See picture A);
  - Use an automatic or pneumatic lubricator, connecting to the dedicated greasing points located on the bearings (See picture B).

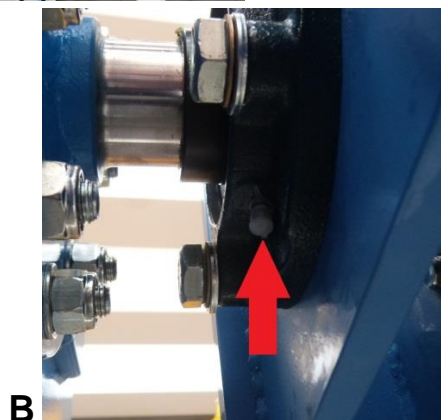
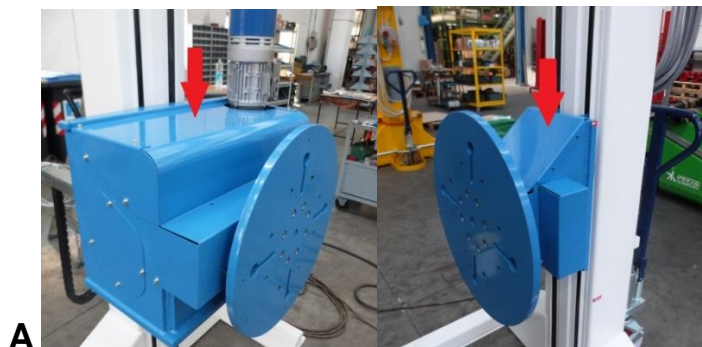

Once the greasing operations have been completed, carry out some in vain rotations of both the master and slave carriage, in order to distribute the grease evenly on the supports.

- Verify the correct tightening of screws, bolts, nuts and all screwed components.
- Verify the condition of fastening anchoring devices and verify that condition of parts in which ergonomic positioner is fixed are without subsidence and cracks.
- In case there are the masses system (optional), it is necessary to apply a special grease lubricant for electrical contacts on the conductor tube in the part in contact with the copper braid. It is necessary to loosen the copper braid on only one side and, using a brush, to apply on the tube a slight stratum of lubricant. At the end of this operation, regenerate the spring traction which has been loosened/extracted before and regulate the tension operating on the regulation screw. SIDEROS suggests the usage of the following products: Kluber Brand type: Kluberlectric KR 44-102; otherwise Molykote Brand HSC type Plus Paste.

## **B.2 - CHECKS**

- **CHECK OF CALIBRATION:** verify, **on carriage of each single column**, that calibration is correctly set (minimum and maximum height):
  1. Verify that the position 0 (zero) is correct.
  2. Lift the columns for about 1 meter and verify, using a rigid meterstick, that the distance between the ground and the carriage is the same, comparing all columns.
  3. Lift the columns at the maximum height and verify, using a rigid meterstick, that the distance between the ground and the carriage is the same, comparing all columns.
  4. If the columns are found to be un-calibrated (with a tolerance of  $\pm 2$  cm) immediately contact local Technical Service Centre SIDEROS MACHINERY: ☎: +39 0523 524066 -- E-Mail: [support@siderosengineering.com](mailto:support@siderosengineering.com)
- **CHECK OF SAFETY SENSORS.** In the carriage back there are 2 sensors (S1 and S2: See the following scheme) for detecting the wear of the nut, and the possible presence of an obstacle under the fork/carriage. Lift carriages for about 60 centimeters. Remove the rear safety window to see the safety nut by the inspection window. Verify the good condition of safety sensors, such as: wear of the nut, micro-obstacle under-fork, its cable and support chain cable. Distance A indicates the wear condition of main nut: in new nut's conditions (without wear), the distance has to be of 3mm approximately; in main nut wear conditions the distance A is equal to 0mm (contact between micro switch and comparison screw). It's forbidden to do a replacement of sensor S1 and comparison screw's adjustments (intentional increase or decrease of distance A)  
When distance A is equal to 0mm, the electronic control display will show the message "WORN NUT ON COLUMN ##".  
Distance B shows if there is or not an obstacle under the lifting carriage: in normal functioning's condition (absence of any obstacle), distance B has to be of approximately 3mm; in case of obstacles under carriage/fork this distance is zero (contact between micro switch and comparison screw).

It's forbidden to do a replacement of sensor S2, comparison screw's adjustments or replace the spring with other different one (intentional increase or decrease of distance B).

When distance B is equal to 0mm, the electronic control display will show the message "OBSTACLE UNDER FORK ON COLUMN ##"

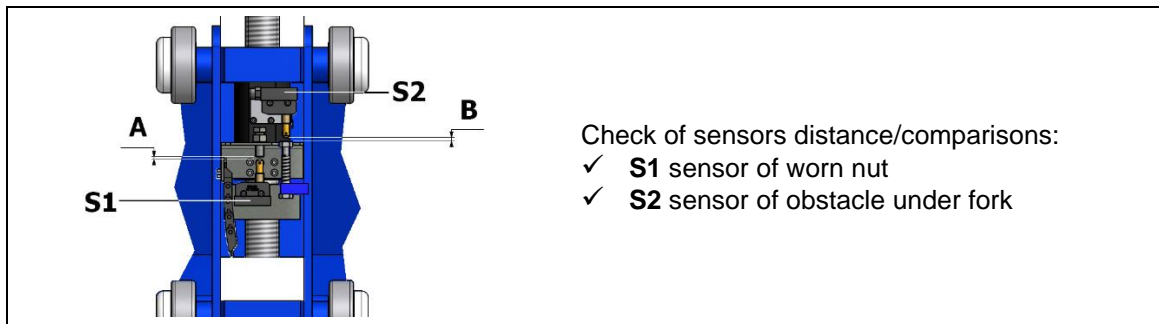

If any, verify conditions of interconnection cables, of mass cable of welding machine and of all parts that constitute the interconnection system. Verify conditions of metallic braids (C) used as "sliding electric masses". In case, some anomalies of damages are encountered, replace damaged devices. To do those verifications it is necessary to remove the cover placed on both motors.

In addition, verify that there are no impurities or dregs on sliding parts placed on conductor pipe (A), which can damage metallic braids during the rotation of flange. In case, remove impurities or dregs.

To carry out those verifications and maintenance operations do as follow:

- Remove flanges on both carriages by using proper lifting equipment.
- Remove protection covers from both carriages (B).

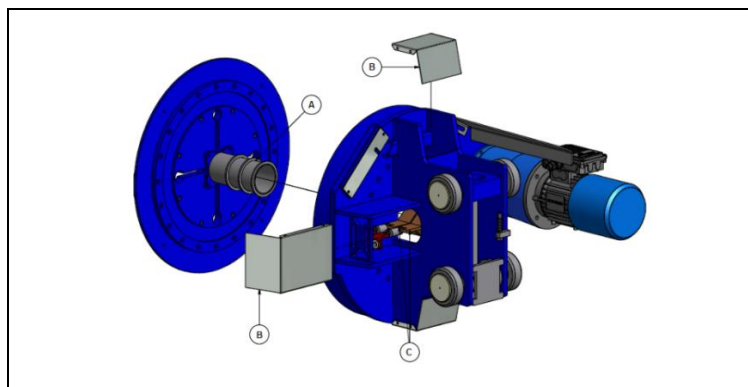

In addition, verify that traction springs guarantee the correct contact between metallic braids and conductor pipe. It is possible to regulate tension on springs by acting on regulation screws.

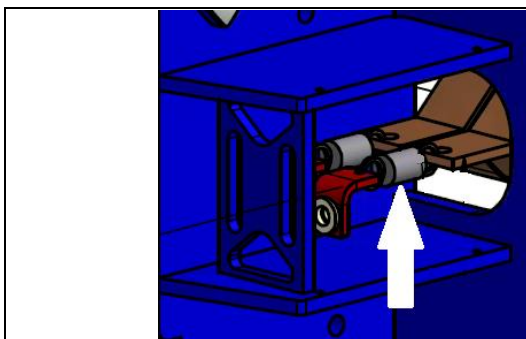

Traction springs



Regulation screws for the traction of springs

Once ended verifications and maintenance operations, re-assembly the protection covers and flanges on master and slave carriages.

Screw the tightening screws of flange by using the dynamometric screw and tightening torque not inferior than 75Nm.

### B.3 PROBLEMS AND SOLUTIONS

SIDEROS MACHINERY cannot accept any liability for injury to people, animals and damage to things caused by unauthorized staff using the equipment.

When fault occurs, it is recommended to promptly contact the technical service department to receive advice about how to carry out work and/or adjustments in maximum safety conditions.

All ERROR messages are matched by a continuous beep.

For more information about malfunctions, alarms and possible solutions, see the Attached Operator Manual.

For a better understanding, the main parts that can cause problems with the operation of the ergonomic positioner are illustrated below:

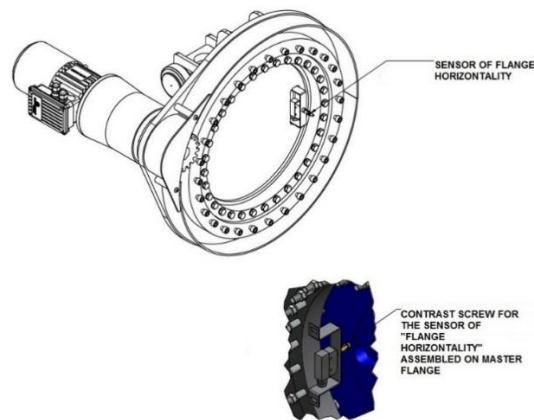

Horizontality sensor of plate



Connectors of self-brake gear motor for the rotation of flange



10-poles connector of the connection cable for devices on anvil

<b>PROBLEM</b>	
<b>PUSHING LEFT /RIGHT ROTATION BUTTONS ON THE PENDANT REMOTE CONTROL UNIT OR TURNING THE LEFT / RIGHT SELECTOR PLACED ON THE CONTROL UNIT, NO PLATE ROTATION OR OPPOSITE ROTATION ARE DONE.</b>	
<b>PROBABLE CAUSE</b>	<b>SOLUTION</b>
Gear motor of rotation is not powered.	<ul style="list-style-type: none"> <li>☑ Connect the 10-poles connector to the control unit</li> <li>☑ Verify that the potentiometer placed outside the control unit isn't positioned in correspondence of the value "0"</li> <li>☑ Verify the electric continuity of cables between connectors of motor and the respective pin of 10-poles connector and replace them if necessary.</li> </ul>
Brake of the rotation gear motor stays activated.	<ul style="list-style-type: none"> <li>☑ Verify the electric continuity of cables between connectors of brake and the respective 10-poles connector pin and replace them if necessary.</li> </ul>
Left / right selector on control unit doesn't work properly.	<ul style="list-style-type: none"> <li>☑ Verify that all cables are properly connected and that all NA contacts aren't damaged. In case, replace the damaged parts.</li> </ul>
Carriage is under the safety area. During that condition, only ascent / descent movements are allowed.	<ul style="list-style-type: none"> <li>☑ Verify the value of the safety threshold planned by the control unit.</li> </ul>
Devices of cinematic chain of rotation are blocked.	<ul style="list-style-type: none"> <li>☑ Contact Technical Service Center SIDEROS MACHINERY: ☎: +39 0523 524066 - E-mail: <a href="mailto:support@siderosengineering.com">support@siderosengineering.com</a></li> </ul>
Pendant remote-control unit isn't connected.	<ul style="list-style-type: none"> <li>☑ Connect the 16-poles connector of the pendant remote-control to the control unit and select the "PENDANT REMOTE-CONTROL" order from the key selector on the panel</li> </ul>
Buttons or interconnection cable of the pendant remote-control are damaged	<ul style="list-style-type: none"> <li>☑ Open the plastic box of the pendant remote-control and check with a tester the electrical continuity of the interconnection cable and the integrity of the contacts on the buttons. If they are damaged, replace them.</li> </ul>
Directions on the panel or pendant remote-control are used but the key selector is not set correctly	<ul style="list-style-type: none"> <li>☑ If using the buttons on the pendant remote-control, select from the key selector the operation "PENDANT REMOTE-CONTROL"</li> <li>☑ If using the buttons on the control unit, select from the key selector the operation "CONTROL UNIT"</li> </ul>

<b>PROBLEM</b>	
<b>PUSHING THE DESCENT BUTTON, NO MOVEMENT OF CARRIAGE IS CARRIED OUT</b>	
<b>PROBABLE CAUSE</b>	<b>SOLUTION</b>
Rotation direction of motor for the flange rotation is incorrect	<input checked="" type="checkbox"/> Invert two of the three power phases of the motor in the 16-poles connector.
Carriage is under the safety area and the plate isn't in horizontality condition.	<input checked="" type="checkbox"/> Carry out an ascent maneuver up to the safety area (Verify the value of the safety threshold planned by the control unit.). Then, carry out a rotation maneuver of plate until the horizontality sensor is activated.
Rotation sensor is damaged.	<input checked="" type="checkbox"/> Verify that the plate is inside the safety area. If it isn't in that area, verify that the sensor is intact and in case replace it. <input checked="" type="checkbox"/> Verify the electric continuity of cables between sensors and 16-poles connector. If it is necessary, replace them.
The functioning of controls has been inhibited by the selector "control unit – pendant" placed on the control unit.	<input checked="" type="checkbox"/> Turn the selector "control unit – pendant" selecting CONTROL UNIT. If it is necessary to work with buttons on the main controller or, selecting PENDANT if it's necessary to work with buttons on remote controller.

<b>PROBLEM</b>	
<b>DURING ROTATION PHASES, PLATE DOESN'T STOP IN CORRESPONDENCE WITH THE HORIZONTALITY POSITION.</b>	
<b>PROBABLE CAUSE</b>	<b>SOLUTION</b>
Comparison screw of horizontality sensor is damaged or was taken away.	<input checked="" type="checkbox"/> Verify that the comparison screw is properly placed and that activates the horizontality sensor.
Horizontality sensor is damaged	<input checked="" type="checkbox"/> Verify that horizontality sensor is intact and in case, replace it. <input checked="" type="checkbox"/> Verify the electric continuity of connection cable between sensor and the respective 10-poles pin connector and in case replace it.
Parameters of inverter placed inside the control unit are incorrect.	<input checked="" type="checkbox"/> Contact Technical Service Center SIDEROS MACHINERY: ☎: +39 0523 524066 – E-mail: <a href="mailto:support@siderosengineering.com">support@siderosengineering.com</a>
Inverter placed inside the control unit is damaged.	<input checked="" type="checkbox"/> Contact Technical Service Center SIDEROS MACHINERY: ☎: +39 0523 524066 – E-mail: <a href="mailto:support@siderosengineering.com">support@siderosengineering.com</a>

<b>PROBLEM</b>	
<b>DURING THE WELDING OPERATIONS ON THE WORKPIECE, THERE IS NOT THE CLOSURE OF THE ELECTRIC ARC.</b>	
<b>PROBABLE CAUSE</b>	<b>SOLUTION</b>
Metallic braid doesn't make contact with the conductor pipe.	<input checked="" type="checkbox"/> By removing the protection cover, verify that braid isn't damaged. In case, replace it.
Interconnection cable with mass cable is damaged.	<input checked="" type="checkbox"/> Replace the interconnection cable
Traction springs don't keep in contact metallic braids with conductor pipe.	<input checked="" type="checkbox"/> Remove the protection covers and verify that springs aren't damaged. In case, replace them. <input checked="" type="checkbox"/> Springs are intact. Act on regulation screws to put springs under the correct tension.
Conductor pipe is no more in contact with the flange.	<input checked="" type="checkbox"/> Remove the flange and verify that tightening screws of the conductor pipe are properly screwed.

# PART C

## INSPECTION BOOK

### CONTENTS

**C.1 - COMPLIANCE WITH STANDARD REFERENCE**

**C.2 - IDENTIFICATION OF THE MACHINE**

**C.3 - INSTRUCTIONS FOR FILLING OUT**

**C.4 - DELIVERY TO THE FIRST OWNER**

**C.5 - TRANSFER OF OWNERSHIP**

**C.6 - PERIODICAL INSPECTIONS**

**C.7 - EXTRAORDINARY MAINTENANCES AND REPAIRS**

### **C.1 - COMPLIANCE WITH REFERENCE STANDARD**

This Inspection Book is released by SIDEROS MACHINERY S.r.l. to the user of the lifting equipment, according to the Annex 1 of the Legislative Decree 27 dated January 2010 n. 17 (execution of Machine Directive 2006/42/CE).

### **C.2 - IDENTIFICATION OF THE MACHINE**

Main description of ergonomic positioner: MASTER column

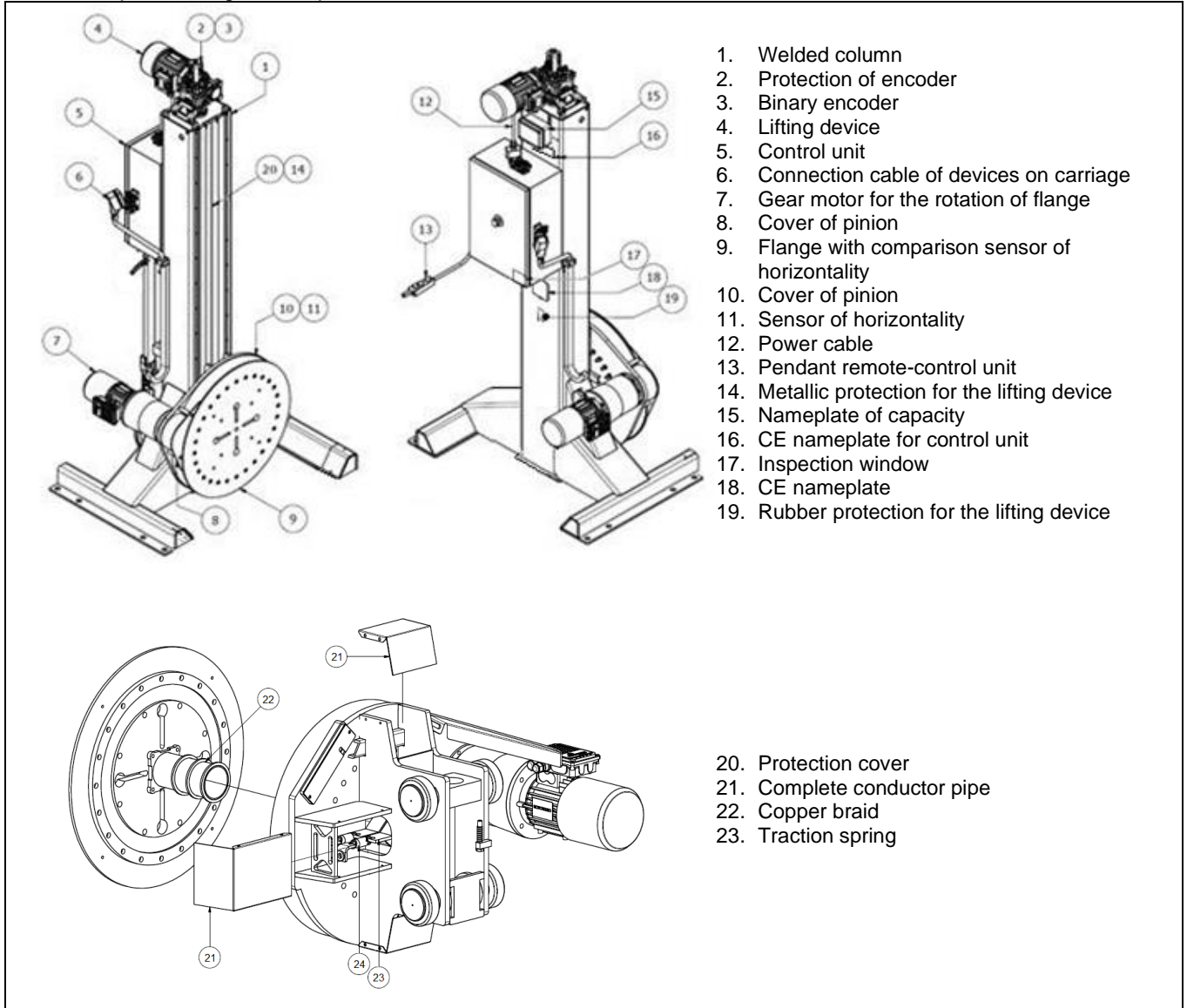

NOTE: Marking and technical description: see Manual Part A

Main description of ergonomic positioner: SLAVE column

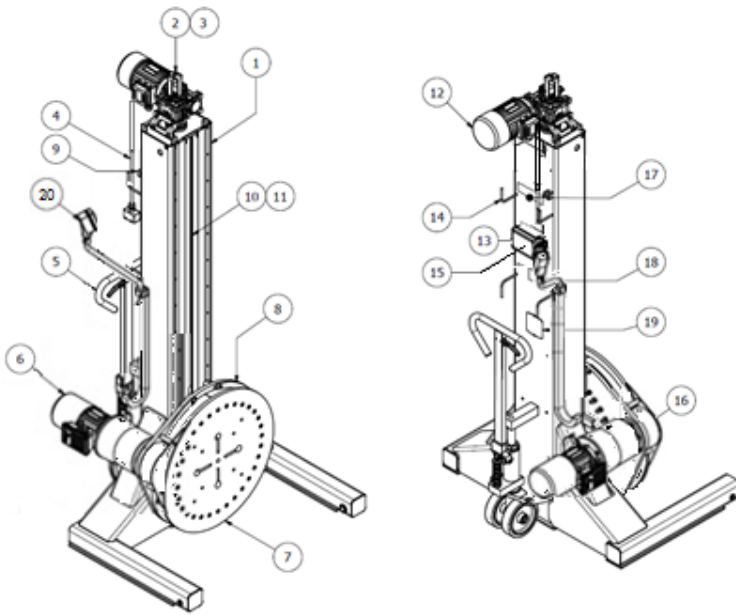

1. Welded column
2. Protection of encoder
3. Binary encoder
4. Interconnection cable
5. Hydraulic jack
6. Cover of slave pinion
7. Flange
8. Complete carriage
9. Collar
10. Metallic protection for the lifting device
11. Rubber protection for the lifting device
12. Lifting device
13. Box with electronic card for encoder
14. Hooks for cable
15. Emergency button
16. Connector for the interconnection cable
17. Nameplate of capacity
18. CE nameplate
19. Nameplate of capacity
20. Control unit – rotation horizontality connector

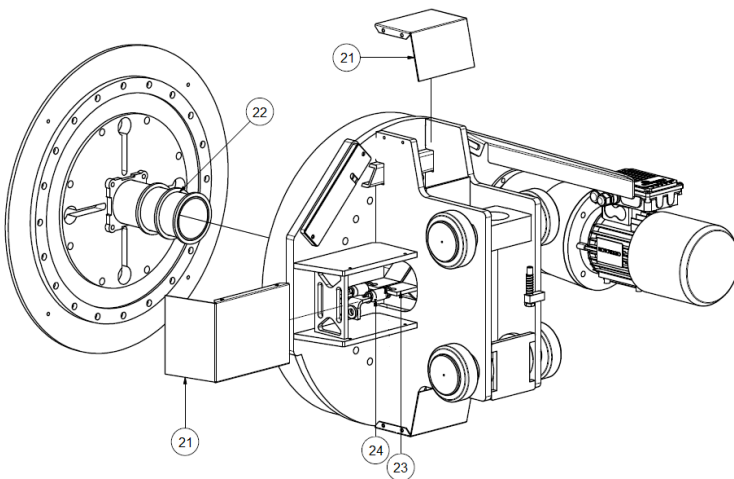

21. Protection cover
22. Complete conductor pipe
23. Copper braid
24. Traction spring

NOTE: Marking and technical description: see Manual Part A

**C.3 - INSTRUCTIONS FOR FILLING OUT**

These instructions have been given according to provisions known at the date of the first commercialization of the lifting equipment. New provisions may intervene and modify the user's obligations.

This Book is arranged to record, according to the proposed schemes, the following events concerning the working life of the lifting equipment, i.e.: Transfers of ownership, Failures of a certain entity and relevant repairs, periodic checks (maintenance).

NOTE: If the sheets of this Book should not be enough, add other sheets drawn up according to the schemes indicated below. On the added sheets, the user shall indicate: type of lifting equipment, serial number, year of construction. The added sheets will be an integral part of this Book.

**C.4 - DELIVERY TO THE FIRST OWNER**

The SIDEROS MACHINERY lifting equipment, SLC series, made up of columns and control unit having the following part numbers:

columns		
Control unit		

Has been delivered by SIDEROS MACHINERY S.r.l., on ....., to the Company:  
.....  
according to the contract conditions agreed, with the technical, dimensional and functional features specified in the instruction manual delivered with the equipment.

**SIDEROS MACHINERY S.r.l.**

**C.5 - TRANSFER OF OWNERSHIP**

On..... the ownership of the aforementioned lifting equipment is transferred to the Company:  
.....  
It is stated that on the above date, the technical, dimensional and functional features of the aforementioned lifting equipment comply with the original features and that any modification has been reported on this Book.

The Seller

The Buyer

.....

.....

### **C.6 - PERIODICAL INSPECTIONS**

To be completed by the maintenance technician.

N°	DATE	NOTES AT THE END OF THE CHECK	SIGNATURE
1			

Main nut wear check.....	<input type="checkbox"/>	Calibration columns control.....	<input type="checkbox"/>
Lifting screw lubrication control.....	<input type="checkbox"/>	Slide guide of carriage lubrication control.....	<input type="checkbox"/>
Thrust bearing lubrication control .....	<input type="checkbox"/>	Tightening torque control of retention screw and bolts.	<input type="checkbox"/>
Micro obstacle/wear condition control.....	<input type="checkbox"/>	Condition of electric cables and connectors control.....	<input type="checkbox"/>
Carriage oscillation condition control.....	<input type="checkbox"/>	Main switch of control unit.....	<input type="checkbox"/>
Up/down and emergency control.....	<input type="checkbox"/>	Stickers position check .....	<input type="checkbox"/>

N°	DATE	NOTES AT THE END OF THE CHECK	SIGNATURE
2			

Main nut wear check.....	<input type="checkbox"/>	Calibration columns control.....	<input type="checkbox"/>
Lifting screw lubrication control.....	<input type="checkbox"/>	Slide guide of carriage lubrication control.....	<input type="checkbox"/>
Thrust bearing lubrication control .....	<input type="checkbox"/>	Tightening torque control of retention screw and bolts.	<input type="checkbox"/>
Micro obstacle/wear condition control.....	<input type="checkbox"/>	Condition of electric cables and connectors control.....	<input type="checkbox"/>
Carriage oscillation condition control.....	<input type="checkbox"/>	Main switch of control unit.....	<input type="checkbox"/>
Up/down and emergency control.....	<input type="checkbox"/>	Stickers position check.....	<input type="checkbox"/>

N°	DATE	NOTES AT THE END OF THE CHECK	SIGNATURE
3			

Main nut wear check.....	<input type="checkbox"/>	Calibration columns control.....	<input type="checkbox"/>
Lifting screw lubrication control.....	<input type="checkbox"/>	Slide guide of carriage lubrication control.....	<input type="checkbox"/>
Thrust bearing lubrication control .....	<input type="checkbox"/>	Tightening torque control of retention screw and bolts.	<input type="checkbox"/>
Micro obstacle/wear condition control.....	<input type="checkbox"/>	Condition of electric cables and connectors control.....	<input type="checkbox"/>
Carriage oscillation condition control.....	<input type="checkbox"/>	Main switch of control unit.....	<input type="checkbox"/>
Up/down and emergency control.....	<input type="checkbox"/>	Stickers position check.....	<input type="checkbox"/>

N°	DATE	NOTES AT THE END OF THE CHECK	SIGNATURE
4			

Main nut wear check.....	<input type="checkbox"/>	Calibration columns control.....	<input type="checkbox"/>
Lifting screw lubrication control.....	<input type="checkbox"/>	Slide guide of carriage lubrication control.....	<input type="checkbox"/>
Thrust bearing lubrication control .....	<input type="checkbox"/>	Tightening torque control of retention screw and bolts.	<input type="checkbox"/>
Micro obstacle/wear condition control.....	<input type="checkbox"/>	Condition of electric cables and connectors control.....	<input type="checkbox"/>
Carriage oscillation condition control.....	<input type="checkbox"/>	Main switch of control unit.....	<input type="checkbox"/>
Up/down and emergency control.....	<input type="checkbox"/>	Stickers position check.....	<input type="checkbox"/>

N°	DATE	NOTES AT THE END OF THE CHECK	SIGNATURE
5			

Main nut wear check.....	<input type="checkbox"/>	Calibration columns control.....	<input type="checkbox"/>
Lifting screw lubrication control.....	<input type="checkbox"/>	Slide guide of carriage lubrication control.....	<input type="checkbox"/>
Thrust bearing lubrication control .....	<input type="checkbox"/>	Tightening torque control of retention screw and bolts.	<input type="checkbox"/>
Micro obstacle/wear condition control.....	<input type="checkbox"/>	Condition of electric cables and connectors control.....	<input type="checkbox"/>
Carriage oscillation condition control.....	<input type="checkbox"/>	Main switch of control unit.....	<input type="checkbox"/>
Up/down and emergency control.....	<input type="checkbox"/>	Stickers position check.....	<input type="checkbox"/>

N°	DATE	NOTES AT THE END OF THE CHECK	SIGNATURE
6			

Main nut wear check.....	<input type="checkbox"/>	Calibration columns control.....	<input type="checkbox"/>
Lifting screw lubrication control.....	<input type="checkbox"/>	Slide guide of carriage lubrication control.....	<input type="checkbox"/>
Thrust bearing lubrication control .....	<input type="checkbox"/>	Tightening torque control of retention screw and bolts.	<input type="checkbox"/>
Micro obstacle/wear condition control.....	<input type="checkbox"/>	Condition of electric cables and connectors control.....	<input type="checkbox"/>
Carriage oscillation condition control.....	<input type="checkbox"/>	Main switch of control unit.....	<input type="checkbox"/>
Up/down and emergency control.....	<input type="checkbox"/>	Stickers position check .....	<input type="checkbox"/>

N°	DATE	NOTES AT THE END OF THE CHECK	SIGNATURE
7			

Main nut wear check.....	<input type="checkbox"/>	Calibration columns control.....	<input type="checkbox"/>
Lifting screw lubrication control.....	<input type="checkbox"/>	Slide guide of carriage lubrication control.....	<input type="checkbox"/>
Thrust bearing lubrication control .....	<input type="checkbox"/>	Tightening torque control of retention screw and bolts.	<input type="checkbox"/>
Micro obstacle/wear condition control.....	<input type="checkbox"/>	Condition of electric cables and connectors control.....	<input type="checkbox"/>
Carriage oscillation condition control.....	<input type="checkbox"/>	Main switch of control unit.....	<input type="checkbox"/>
Up/down and emergency control.....	<input type="checkbox"/>	Stickers position check .....	<input type="checkbox"/>

N°	DATE	NOTES AT THE END OF THE CHECK	SIGNATURE
8			

Main nut wear check.....	<input type="checkbox"/>	Calibration columns control.....	<input type="checkbox"/>
Lifting screw lubrication control.....	<input type="checkbox"/>	Slide guide of carriage lubrication control.....	<input type="checkbox"/>
Thrust bearing lubrication control .....	<input type="checkbox"/>	Tightening torque control of retention screw and bolts.	<input type="checkbox"/>
Micro obstacle/wear condition control.....	<input type="checkbox"/>	Condition of electric cables and connectors control.....	<input type="checkbox"/>
Carriage oscillation condition control.....	<input type="checkbox"/>	Main switch of control unit.....	<input type="checkbox"/>
Up/down and emergency control.....	<input type="checkbox"/>	Stickers position check .....	<input type="checkbox"/>

N°	DATE	NOTES AT THE END OF THE CHECK	SIGNATURE
9			

Main nut wear check.....	<input type="checkbox"/>	Calibration columns control.....	<input type="checkbox"/>
Lifting screw lubrication control.....	<input type="checkbox"/>	Slide guide of carriage lubrication control.....	<input type="checkbox"/>
Thrust bearing lubrication control .....	<input type="checkbox"/>	Tightening torque control of retention screw and bolts.	<input type="checkbox"/>
Micro obstacle/wear condition control.....	<input type="checkbox"/>	Condition of electric cables and connectors control.....	<input type="checkbox"/>
Carriage oscillation condition control.....	<input type="checkbox"/>	Main switch of control unit.....	<input type="checkbox"/>
Up/down and emergency control.....	<input type="checkbox"/>	Stickers position check .....	<input type="checkbox"/>

N°	DATE	NOTES AT THE END OF THE CHECK	SIGNATURE
10			

Main nut wear check.....	<input type="checkbox"/>	Calibration columns control.....	<input type="checkbox"/>
Lifting screw lubrication control.....	<input type="checkbox"/>	Slide guide of carriage lubrication control.....	<input type="checkbox"/>
Thrust bearing lubrication control .....	<input type="checkbox"/>	Tightening torque control of retention screw and bolts.	<input type="checkbox"/>
Micro obstacle/wear condition control.....	<input type="checkbox"/>	Condition of electric cables and connectors control.....	<input type="checkbox"/>
Carriage oscillation condition control.....	<input type="checkbox"/>	Main switch of control unit.....	<input type="checkbox"/>
Up/down and emergency control.....	<input type="checkbox"/>	Stickers position check .....	<input type="checkbox"/>

N°	DATE	NOTES AT THE END OF THE CHECK	SIGNATURE
11			

Main nut wear check.....	<input type="checkbox"/>	Calibration columns control.....	<input type="checkbox"/>
Lifting screw lubrication control.....	<input type="checkbox"/>	Slide guide of carriage lubrication control.....	<input type="checkbox"/>
Thrust bearing lubrication control .....	<input type="checkbox"/>	Tightening torque control of retention screw and bolts.	<input type="checkbox"/>
Micro obstacle/wear condition control.....	<input type="checkbox"/>	Condition of electric cables and connectors control.....	<input type="checkbox"/>
Carriage oscillation condition control.....	<input type="checkbox"/>	Main switch of control unit.....	<input type="checkbox"/>
Up/down and emergency control.....	<input type="checkbox"/>	Stickers position check .....	<input type="checkbox"/>

N°	DATE	NOTES AT THE END OF THE CHECK	SIGNATURE
12			

Main nut wear check.....	<input type="checkbox"/>	Calibration columns control.....	<input type="checkbox"/>
Lifting screw lubrication control.....	<input type="checkbox"/>	Slide guide of carriage lubrication control.....	<input type="checkbox"/>
Thrust bearing lubrication control .....	<input type="checkbox"/>	Tightening torque control of retention screw and bolts.	<input type="checkbox"/>
Micro obstacle/wear condition control.....	<input type="checkbox"/>	Condition of electric cables and connectors control.....	<input type="checkbox"/>
Carriage oscillation condition control.....	<input type="checkbox"/>	Main switch of control unit.....	<input type="checkbox"/>
Up/down and emergency control.....	<input type="checkbox"/>	Stickers position check .....	<input type="checkbox"/>

N°	DATE	NOTES AT THE END OF THE CHECK	SIGNATURE
13			

Main nut wear check.....	<input type="checkbox"/>	Calibration columns control.....	<input type="checkbox"/>
Lifting screw lubrication control.....	<input type="checkbox"/>	Slide guide of carriage lubrication control.....	<input type="checkbox"/>
Thrust bearing lubrication control .....	<input type="checkbox"/>	Tightening torque control of retention screw and bolts.	<input type="checkbox"/>
Micro obstacle/wear condition control.....	<input type="checkbox"/>	Condition of electric cables and connectors control.....	<input type="checkbox"/>
Carriage oscillation condition control.....	<input type="checkbox"/>	Main switch of control unit.....	<input type="checkbox"/>
Up/down and emergency control.....	<input type="checkbox"/>	Stickers position check .....	<input type="checkbox"/>

N°	DATE	NOTES AT THE END OF THE CHECK	SIGNATURE
14			

Main nut wear check.....	<input type="checkbox"/>	Calibration columns control.....	<input type="checkbox"/>
Lifting screw lubrication control.....	<input type="checkbox"/>	Slide guide of carriage lubrication control.....	<input type="checkbox"/>
Thrust bearing lubrication control .....	<input type="checkbox"/>	Tightening torque control of retention screw and bolts.	<input type="checkbox"/>
Micro obstacle/wear condition control.....	<input type="checkbox"/>	Condition of electric cables and connectors control.....	<input type="checkbox"/>
Carriage oscillation condition control.....	<input type="checkbox"/>	Main switch of control unit.....	<input type="checkbox"/>
Up/down and emergency control.....	<input type="checkbox"/>	Stickers position check .....	<input type="checkbox"/>

N°	DATE	NOTES AT THE END OF THE CHECK	SIGNATURE
15			

Main nut wear check.....	<input type="checkbox"/>	Calibration columns control.....	<input type="checkbox"/>
Lifting screw lubrication control.....	<input type="checkbox"/>	Slide guide of carriage lubrication control.....	<input type="checkbox"/>
Thrust bearing lubrication control .....	<input type="checkbox"/>	Tightening torque control of retention screw and bolts.	<input type="checkbox"/>
Micro obstacle/wear condition control.....	<input type="checkbox"/>	Condition of electric cables and connectors control.....	<input type="checkbox"/>
Carriage oscillation condition control.....	<input type="checkbox"/>	Main switch of control unit.....	<input type="checkbox"/>
Up/down and emergency control.....	<input type="checkbox"/>	Stickers position check .....	<input type="checkbox"/>

N°	DATE	NOTES AT THE END OF THE CHECK	SIGNATURE
16			

Main nut wear check.....	<input type="checkbox"/>	Calibration columns control.....	<input type="checkbox"/>
Lifting screw lubrication control.....	<input type="checkbox"/>	Slide guide of carriage lubrication control.....	<input type="checkbox"/>
Thrust bearing lubrication control .....	<input type="checkbox"/>	Tightening torque control of retention screw and bolts.	<input type="checkbox"/>
Micro obstacle/wear condition control.....	<input type="checkbox"/>	Condition of electric cables and connectors control.....	<input type="checkbox"/>
Carriage oscillation condition control.....	<input type="checkbox"/>	Main switch of control unit.....	<input type="checkbox"/>
Up/down and emergency control.....	<input type="checkbox"/>	Stickers position check .....	<input type="checkbox"/>

N°	DATE	NOTES AT THE END OF THE CHECK	SIGNATURE
17			

Main nut wear check.....	<input type="checkbox"/>	Calibration columns control.....	<input type="checkbox"/>
Lifting screw lubrication control.....	<input type="checkbox"/>	Slide guide of carriage lubrication control.....	<input type="checkbox"/>
Thrust bearing lubrication control .....	<input type="checkbox"/>	Tightening torque control of retention screw and bolts.	<input type="checkbox"/>
Micro obstacle/wear condition control.....	<input type="checkbox"/>	Condition of electric cables and connectors control.....	<input type="checkbox"/>
Carriage oscillation condition control.....	<input type="checkbox"/>	Main switch of control unit.....	<input type="checkbox"/>
Up/down and emergency control.....	<input type="checkbox"/>	Stickers position check .....	<input type="checkbox"/>

N°	DATE	NOTES AT THE END OF THE CHECK	SIGNATURE
18			

Main nut wear check.....	<input type="checkbox"/>	Calibration columns control.....	<input type="checkbox"/>
Lifting screw lubrication control.....	<input type="checkbox"/>	Slide guide of carriage lubrication control.....	<input type="checkbox"/>
Thrust bearing lubrication control .....	<input type="checkbox"/>	Tightening torque control of retention screw and bolts.	<input type="checkbox"/>
Micro obstacle/wear condition control.....	<input type="checkbox"/>	Condition of electric cables and connectors control.....	<input type="checkbox"/>
Carriage oscillation condition control.....	<input type="checkbox"/>	Main switch of control unit.....	<input type="checkbox"/>
Up/down and emergency control.....	<input type="checkbox"/>	Stickers position check .....	<input type="checkbox"/>

N°	DATE	NOTES AT THE END OF THE CHECK	SIGNATURE
19			

Main nut wear check.....	<input type="checkbox"/>	Calibration columns control.....	<input type="checkbox"/>
Lifting screw lubrication control.....	<input type="checkbox"/>	Slide guide of carriage lubrication control.....	<input type="checkbox"/>
Thrust bearing lubrication control .....	<input type="checkbox"/>	Tightening torque control of retention screw and bolts.	<input type="checkbox"/>
Micro obstacle/wear condition control.....	<input type="checkbox"/>	Condition of electric cables and connectors control.....	<input type="checkbox"/>
Carriage oscillation condition control.....	<input type="checkbox"/>	Main switch of control unit.....	<input type="checkbox"/>
Up/down and emergency control.....	<input type="checkbox"/>	Stickers position check .....	<input type="checkbox"/>

N°	DATE	NOTES AT THE END OF THE CHECK	SIGNATURE
20			

Main nut wear check.....	<input type="checkbox"/>	Calibration columns control.....	<input type="checkbox"/>
Lifting screw lubrication control.....	<input type="checkbox"/>	Slide guide of carriage lubrication control.....	<input type="checkbox"/>
Thrust bearing lubrication control .....	<input type="checkbox"/>	Tightening torque control of retention screw and bolts.	<input type="checkbox"/>
Micro obstacle/wear condition control.....	<input type="checkbox"/>	Condition of electric cables and connectors control.....	<input type="checkbox"/>
Carriage oscillation condition control.....	<input type="checkbox"/>	Main switch of control unit.....	<input type="checkbox"/>
Up/down and emergency control.....	<input type="checkbox"/>	Stickers position check .....	<input type="checkbox"/>

N°	DATE	NOTES AT THE END OF THE CHECK	SIGNATURE
21			

Main nut wear check.....	<input type="checkbox"/>	Calibration columns control.....	<input type="checkbox"/>
Lifting screw lubrication control.....	<input type="checkbox"/>	Slide guide of carriage lubrication control.....	<input type="checkbox"/>
Thrust bearing lubrication control .....	<input type="checkbox"/>	Tightening torque control of retention screw and bolts.	<input type="checkbox"/>
Micro obstacle/wear condition control.....	<input type="checkbox"/>	Condition of electric cables and connectors control.....	<input type="checkbox"/>
Carriage oscillation condition control.....	<input type="checkbox"/>	Main switch of control unit.....	<input type="checkbox"/>
Up/down and emergency control.....	<input type="checkbox"/>	Stickers position check .....	<input type="checkbox"/>

N°	DATE	NOTES AT THE END OF THE CHECK	SIGNATURE
22			

Main nut wear check.....	<input type="checkbox"/>	Calibration columns control.....	<input type="checkbox"/>
Lifting screw lubrication control.....	<input type="checkbox"/>	Slide guide of carriage lubrication control.....	<input type="checkbox"/>
Thrust bearing lubrication control .....	<input type="checkbox"/>	Tightening torque control of retention screw and bolts.	<input type="checkbox"/>
Micro obstacle/wear condition control.....	<input type="checkbox"/>	Condition of electric cables and connectors control.....	<input type="checkbox"/>
Carriage oscillation condition control.....	<input type="checkbox"/>	Main switch of control unit.....	<input type="checkbox"/>
Up/down and emergency control.....	<input type="checkbox"/>	Stickers position check .....	<input type="checkbox"/>

N°	DATE	NOTES AT THE END OF THE CHECK	SIGNATURE
23			

Main nut wear check.....	<input type="checkbox"/>	Calibration columns control.....	<input type="checkbox"/>
Lifting screw lubrication control.....	<input type="checkbox"/>	Slide guide of carriage lubrication control.....	<input type="checkbox"/>
Thrust bearing lubrication control .....	<input type="checkbox"/>	Tightening torque control of retention screw and bolts.	<input type="checkbox"/>
Micro obstacle/wear condition control.....	<input type="checkbox"/>	Condition of electric cables and connectors control.....	<input type="checkbox"/>
Carriage oscillation condition control.....	<input type="checkbox"/>	Main switch of control unit.....	<input type="checkbox"/>
Up/down and emergency control.....	<input type="checkbox"/>	Stickers position check .....	<input type="checkbox"/>

N°	DATE	NOTES AT THE END OF THE CHECK	SIGNATURE
24			

Main nut wear check.....	<input type="checkbox"/>	Calibration columns control.....	<input type="checkbox"/>
Lifting screw lubrication control.....	<input type="checkbox"/>	Slide guide of carriage lubrication control.....	<input type="checkbox"/>
Thrust bearing lubrication control .....	<input type="checkbox"/>	Tightening torque control of retention screw and bolts.	<input type="checkbox"/>
Micro obstacle/wear condition control.....	<input type="checkbox"/>	Condition of electric cables and connectors control.....	<input type="checkbox"/>
Carriage oscillation condition control.....	<input type="checkbox"/>	Main switch of control unit.....	<input type="checkbox"/>
Up/down and emergency control.....	<input type="checkbox"/>	Stickers position check .....	<input type="checkbox"/>

N°	DATE	NOTES AT THE END OF THE CHECK	SIGNATURE
25			

Main nut wear check.....	<input type="checkbox"/>	Calibration columns control.....	<input type="checkbox"/>
Lifting screw lubrication control.....	<input type="checkbox"/>	Slide guide of carriage lubrication control.....	<input type="checkbox"/>
Thrust bearing lubrication control .....	<input type="checkbox"/>	Tightening torque control of retention screw and bolts.	<input type="checkbox"/>
Micro obstacle/wear condition control.....	<input type="checkbox"/>	Condition of electric cables and connectors control.....	<input type="checkbox"/>
Carriage oscillation condition control.....	<input type="checkbox"/>	Main switch of control unit.....	<input type="checkbox"/>
Up/down and emergency control.....	<input type="checkbox"/>	Stickers position check .....	<input type="checkbox"/>

N°	DATE	NOTES AT THE END OF THE CHECK	SIGNATURE
26			

Main nut wear check.....	<input type="checkbox"/>	Calibration columns control.....	<input type="checkbox"/>
Lifting screw lubrication control.....	<input type="checkbox"/>	Slide guide of carriage lubrication control.....	<input type="checkbox"/>
Thrust bearing lubrication control .....	<input type="checkbox"/>	Tightening torque control of retention screw and bolts.	<input type="checkbox"/>
Micro obstacle/wear condition control.....	<input type="checkbox"/>	Condition of electric cables and connectors control.....	<input type="checkbox"/>
Carriage oscillation condition control.....	<input type="checkbox"/>	Main switch of control unit.....	<input type="checkbox"/>
Up/down and emergency control.....	<input type="checkbox"/>	Stickers position check .....	<input type="checkbox"/>

N°	DATE	NOTES AT THE END OF THE CHECK	SIGNATURE
27			

Main nut wear check.....	<input type="checkbox"/>	Calibration columns control.....	<input type="checkbox"/>
Lifting screw lubrication control.....	<input type="checkbox"/>	Slide guide of carriage lubrication control.....	<input type="checkbox"/>
Thrust bearing lubrication control .....	<input type="checkbox"/>	Tightening torque control of retention screw and bolts.	<input type="checkbox"/>
Micro obstacle/wear condition control.....	<input type="checkbox"/>	Condition of electric cables and connectors control.....	<input type="checkbox"/>
Carriage oscillation condition control.....	<input type="checkbox"/>	Main switch of control unit.....	<input type="checkbox"/>
Up/down and emergency control.....	<input type="checkbox"/>	Stickers position check .....	<input type="checkbox"/>



