

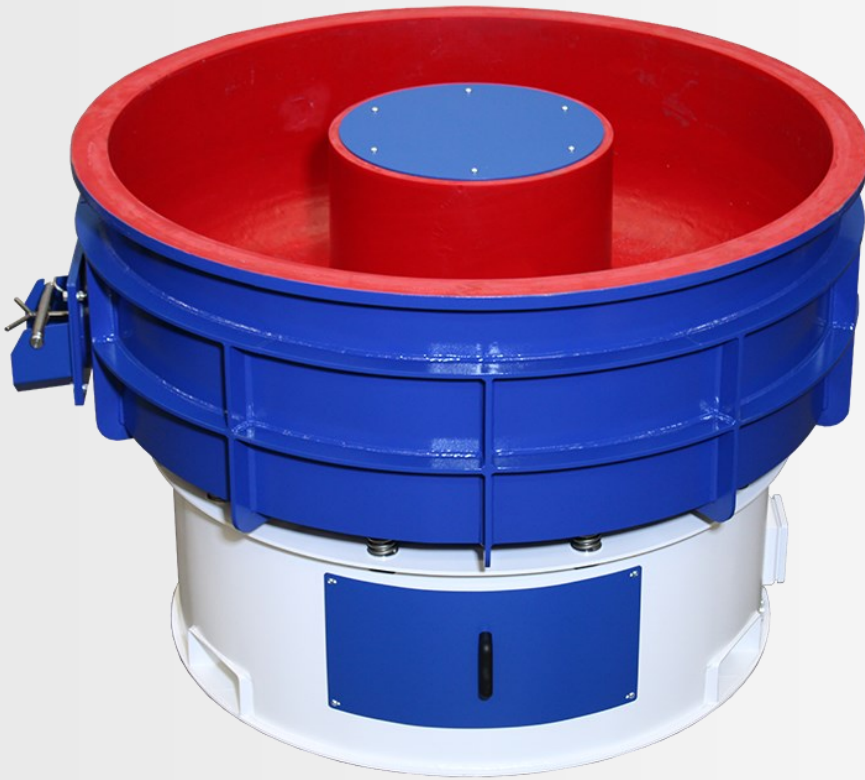

Mass Finishing Technology Process Water Treatment



Circular Vibrators RF

- Round work container
- Flat container bottom without ramp
- Particularly wide working channel in relation to the size of the machine
- High drive power for maximum grinding performance
- Low-maintenance unbalance motor
- Universally adaptable and changeable delivery chutes

Universal and economical

From deburring to rounding edges to high-gloss polishing: circular vibrators are universal vibratory grinding machines that can be used for a wide variety of applications and materials. RF circular vibrators are very versatile and are ideal for particularly large or magnetic workpieces. Due to the simple design, RF circular vibrators are particularly inexpensive and economical. The workpieces are usually separated manually for large components; a magnetic separator can be used for magnetic workpieces.

Technical features:

- Round working container with a flat container bottom
- Particularly wide working channel, even with a small total volume: enables particularly large workpieces to be machined
- Highly wear-resistant, hot-cast special polyurethane protective coating for maximum service life
- Low-maintenance and powerful unbalance motor

Universal and economical
Perfect for large components

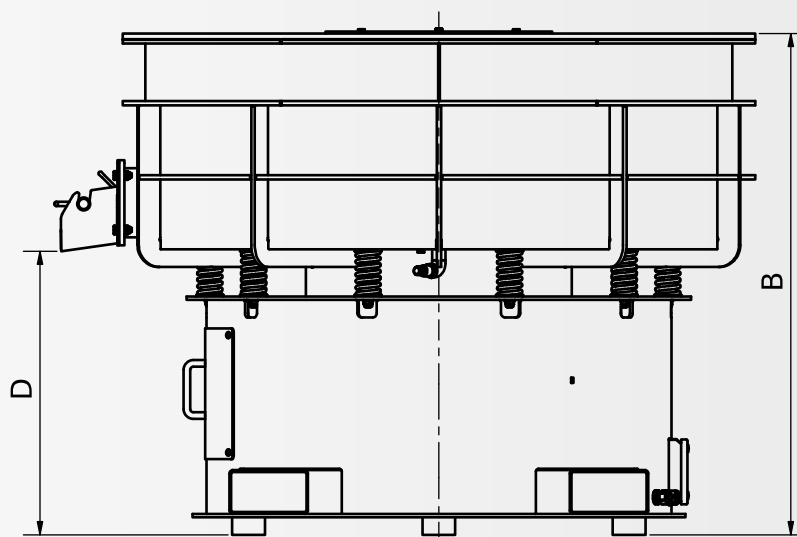
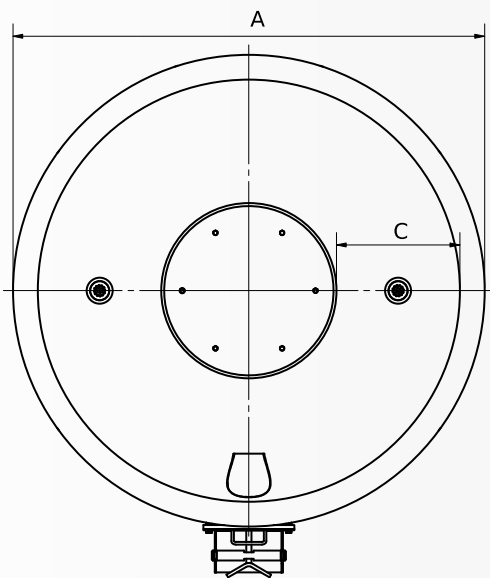

		RF03	RF06	RF08	RF11	RF16	RF20	RF26	RF36
Volume (gross)	liter	130	230	330	430	640	800	1060	1460
Drive power max.	kW	1,9	2,5	3	3	3/7	7	7	11
Outer diameter (A)	mm	1000	1200	1350	1450	1650	1820	2000	2000
Total height (B)	mm	1020	1080	1110	1150	1210	1230	1270	1320
Channel width (C)	mm	220	270	340	370	440	470	520	650
Height of stone outlet(D)	mm	650	650	650	650	650	650	650	650
Channel height	mm	310	370	400	440	480	500	560	600

Areas of application:

- Large components with complex geometry
- Processing of magnetic workpieces: Discharge by means of a magnetic separator
- Heavy components
- Sensitive components that could be damaged by falling steps

Equipment:

- Increased drive power for ball polishing as well as for special processes
- Frequency-controlled drive with variable speed control
- PLC-controlled electrical switchgear for partially and fully automated system operation and for optimized process control
- Dosing systems for process media and additives
- Circumferential triangular profile to reduce component build-up on the container wall
- Sound insulation concepts such as sound insulation covers and complete enclosures
- Magnetic separator
- Extended process water management concepts (ring showers, distributor nozzles, rinsing systems, washing nozzles, backwash systems, ...)
- Moving partition walls for contact-free vibratory grinding of several components
- Pinch valves for vibratory grinding with high water levels
- Further special accessories (on request)



Circular Vibrators RE

- Round vibrator "Economy": Full performance with selected options
- Round working container with rising container bottom and built-in separating sieve
- Tangential outlet with quick-change screen surface
- Highly wear-resistant molded polyurethane protective coating
- Low-maintenance unbalance motor

Simple and inexpensive

As universal vibratory finishing machines, RE circular vibrators are the ideal machine for basic applications in vibratory finishing. As a cost-effective entry-level machine, the surface finishing vibrators combine maximum performance with simple operation. Depending on the component dimensions and batch quantity, the RE round vibrators are available in various container sizes with volumes from 150 to 1,550 liters. With options tailored to the series, RE circular vibrators can be adapted to customer requirements. In addition to options in the area of sound insulation, there are also magnetic separators or suitable circular dryers to choose from.

Areas of application:

- Vibratory grinding and polishing of bulk goods in large quantities
- Rust removal, descaling, deburring, rounding
- Processing of various materials (aluminum, steel, stainless steel, plastic, ...)
- Fine grinding and polishing of workpieces

Simple and inexpensive

The entry-level model

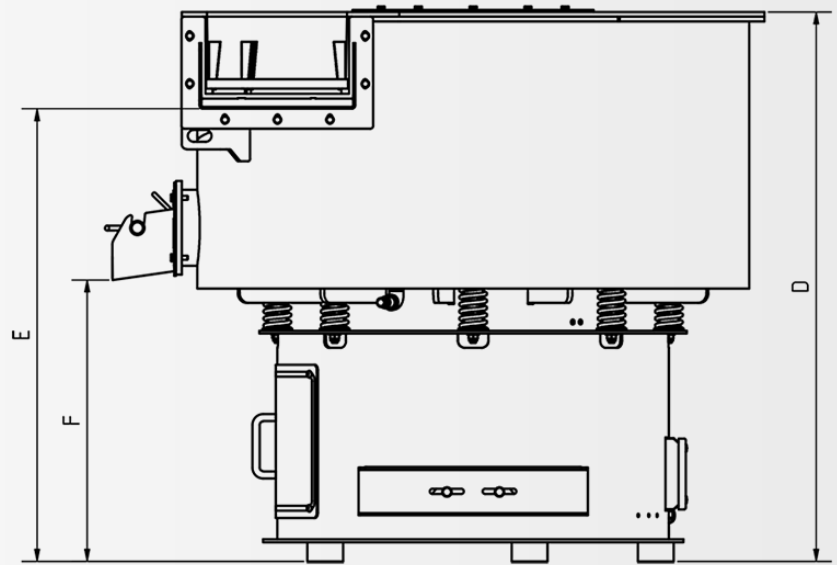
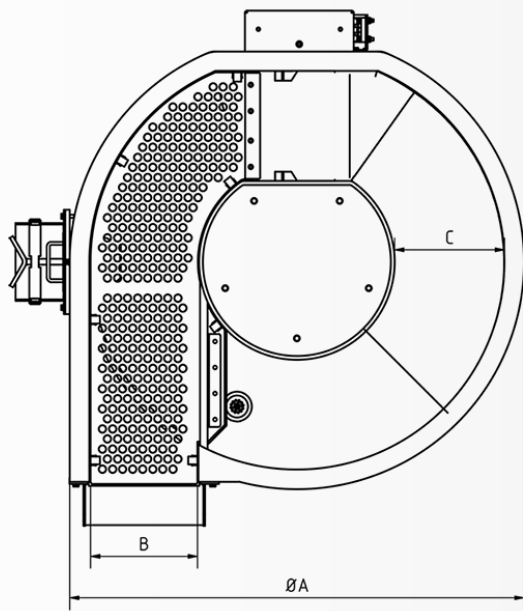

		RE06	RE11	RE16	RE21	RE31	RE41	RE61	RE76
Volume (gross)	liter	150	250	350	450	650	820	1220	1550
Usable volume (net)	liter	105	175	250	310	450	550	870	1100
Drive power max.	kW	1,9	2,5	3	3	7	7	7	11
Outer diameter (A)	mm	1150	1220	1420	1480	1780	1850	2050	2200
Wire width (B)	mm	265	285	370	400	475	490	500	575
Channel width (C)	mm	230	260	330	360	440	450	460	530
Total height (D)	mm	1165	1210	1280	1310	1410	1500	1770	1820
Delivery level (E)	mm	960	1000	1030	1040	1090	1170	1370	1420
Height of stone outlet(F)	mm	650	650	650	650	650	650	700	700

Equipment:

- A wide variety of electrical switchgears depending on the requirements
- Time switch for process control (timer)
- Frequency-controlled drive with variable speed control
- Circumferential triangular profile to reduce component build-up on the container wall
- Pneumatically operated flap for separation (included as standard from RE31)
- Sound insulation cover to reduce noise emissions
- Magnetic separator for component separation
- Dosing systems for process media and additives (compounds, flocculants, ...)

If a linkage and other special accessories are required, this is available for the round vibrators of the "RA" series.



Circular Vibrators RA

- Round working container with built-in separating sieve
- Flat rising container bottom
- Pneumatically controlled flap for separating
- Tangential outlet with quick-change screen surface
- Highly wear-resistant molded polyurethane protective coating
- Low-maintenance unbalance motor

Versatile and economical

Deburring, rounding or polishing: RA rotary vibrators are universal slide grinding machines that can be used for a wide range of applications. They offer a high grinding performance and impress with their ease of use combined with high reliability. With numerous options, the machine can be configured precisely to the requirements.

RA round vibrators are particularly suitable for processing bulk goods in large quantities. The workpieces are reliably guided onto the built-in sieve surface thanks to the gently rising container bottom. The large sieve surface with tangential outlet ensures reliable workpiece separation and offers the option of using magnetic separators.

Areas of application:

- Vibratory grinding and polishing of bulk goods in large quantities
- Rust removal, descaling, deburring, rounding
- Processing of various materials (aluminum, steel, stainless steel, plastic, ...)

Versatile and economical
Ideal for large quantities

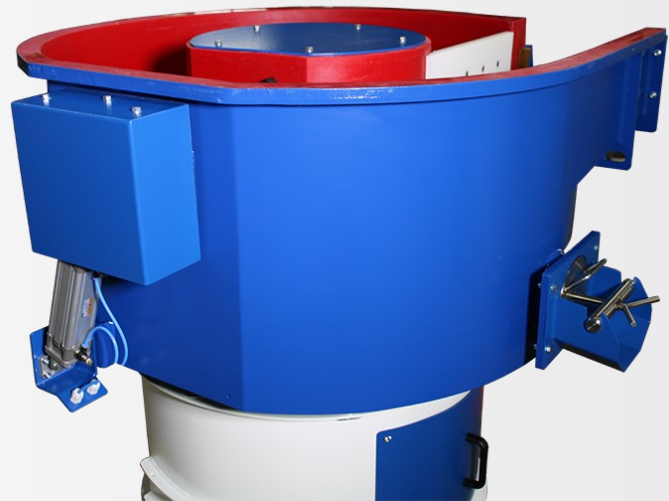

Technical features:

- Round working container with an evenly and gently rising container bottom
- Drop step for separating stuck workpieces (optionally a flowing drop step available for sensitive workpieces)
- Highly wear-resistant, hot-cast special polyurethane protective coating for maximum service life
- Low-maintenance and powerful vibration exciter motor with unbalances that can be adapted to the process (optionally available with adjustable unbalances for automatic ramp exposure)
- Pneumatic flap integrated in the container for separating the workpieces
- Tangential component discharge with large sieve area
- Quick-change sieve plates
- Modular system for the use of different sieve plates and separation systems (reverse separation, magnetic separation, ...)
- Integrated process water supply concept with exchangeable drainage sieve
- Universal attachment option for adding numerous delivery chutes
- Drain opening for quick changing of grinding tools
- Easily accessible service openings
- Possibility of linking the system in a system park (linking with a rotary dryer, conveyor belts, rinsing systems, ...)

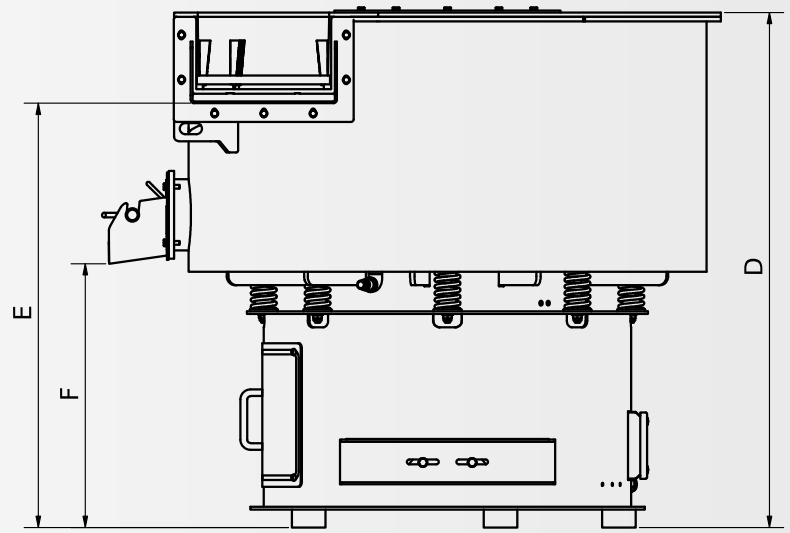
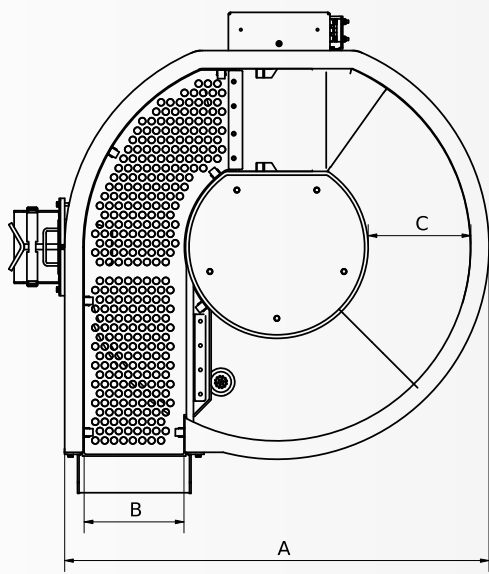

		RA06	RA11	RA16	RA21	RA31	RA41	RA61	RA76
Volume (gross)	liter	150	250	350	450	650	820	1220	1550
Usable volume (net)	liter	105	175	250	310	450	550	870	1100
Drive power max.	kW	1,9	2,5	3	3	7	7	7	11
Outer diameter (A)	mm	1150	1220	1420	1480	1780	1850	2050	2200
Wire width (B)	mm	265	285	370	400	475	490	500	575
Channel width (C)	mm	230	260	330	360	440	450	460	530
Total height (D)	mm	1165	1210	1280	1310	1410	1500	1770	1820
Delivery level (E)	mm	960	1000	1030	1040	1090	1170	1370	1420
Height of stone outlet (F)	mm	650	650	650	650	650	650	700	700

Equipment:

- Ramp exposure through a built-in "reverse gear" (automatically adjustable unbalance of the vibration motor)
- Frequency-controlled drive with variable speed control
- PLC controlled electrical switchgear for partially and fully automated plant operation
- Circumferential triangular profile to reduce component build-up on the container wall
- Different fall step variants (step, ramp)
- Sound insulation concepts (sound insulation covers, soundproof cabins, enclosures)
- Various separation systems for separating material and grinding tools (magnetic separators, reverse separation, scrapers, drop steps, ...)
- Dosing systems for process media and additives (compounds, flocculants, ...)
- Extended process water management concepts (ring showers, distributor nozzles, rinsing systems, washing nozzles, backwash systems, ...)
- Pinch valves for vibratory grinding with high water levels
- Further special accessories (on request)



Circular Vibrators RM

- Round working container without central dome
- Flat container bottom with a wide range of options for attaching workpieces
- Especially for hard-to-reach places and difficult geometries
- Grinding, polishing and high-gloss compaction in one machine thanks to adjustable motor configuration

Versatile and efficient

From deburring to rounding edges to high-gloss polishing: RM rotary vibrators are universal vibratory finishing machines that can be used in a variety of ways. They offer a high level of efficiency and impress with their flexible adaptability to a wide variety of processes.

Our RM round vibrators are particularly suitable for fine-tuning and polishing workpieces that place high demands on the desired surface. The special system structure makes it possible to achieve perfect surfaces even in hard-to-reach places such as corners or inner contours. With a high level of reproducibility and a uniform grinding pattern, RM rotary vibrators offer the highest level of process security and reliability.

For a surface quality
the extra class



Areas of application:

- Grinding, polishing and high-gloss compression of large components
- Machining of aluminum components (rims, intake manifolds, general engine components, housings, levers, ...)
- Polishing of die casting and cutting dies
- Grinding and polishing of medical implants
- Smoothing of forging molds and turbine blades
- Deburring complex component geometries (matrices, punching forms, ...)
- Numerous other possible uses

Advantages:

- Consistent and reproducible processing quality of the grinding and polishing results
- Homogeneous and even sanding pattern
- Possibility to preserve difficult workpiece contours
- Best results even in hard-to-reach places
- Possibility of contact-free grinding of several workpieces in one work container
- Designed for continuous operation, even in 24-hour operation
- Adaptable drive motors for different operating modes (grinding, polishing, compacting, ...)
- Semi-automatic operation possible through electronic process control

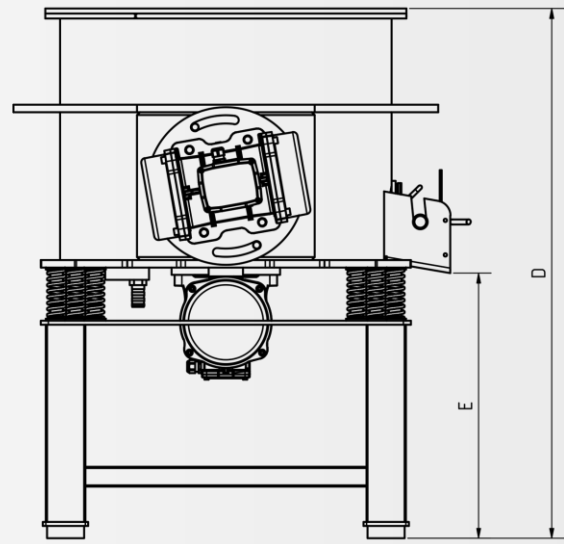
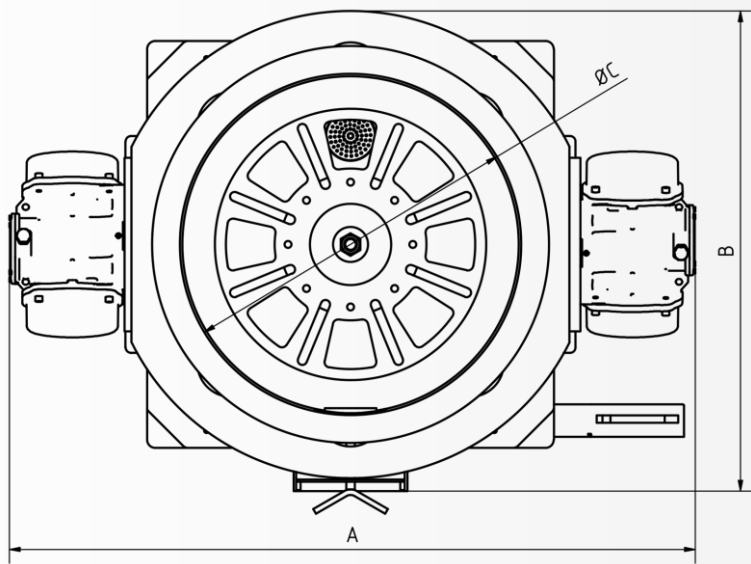

		RM33	RM34	RM54	RM84
Volume (gross)	liter	145	165	260	610
Usable volume	liter	130	150	240	550
Connected load *	kW	3	3	5	12
Total width (A)	mm	1260	1260	1600	2100
Inside diameter (C)	mm	620	620	750	1050
Total height (D)	mm	1085	1150	1230	1310
Output height (E)	mm	530	530	530	530

* The connected load depends on the motor configuration. Two motors are available as standard, three optionally.

Equipment:

- Additional third unbalance motor on the container bottom for an increased vertical oscillating movement
- Electrical switchgear with numerous equipment options
- Frequency-controlled drive with variable speed control
- PLC-controlled electrical switchgear for partially and fully automated system operation and optimized process control
- Dosing systems for process media and additives
- Sound insulation concepts (sound insulation covers, soundproof cabins)
- Pneumatic lifting device for removing components without emptying the grinding tools from the work container
- Various clamping systems for fixing workpieces in the work container (magnetic clamping devices, lifting devices, multi-clamping devices, ...)
- Extended process water management concepts (ring showers, distributor nozzles, rinsing systems, washing nozzles, ...)
- Further special accessories (on request)

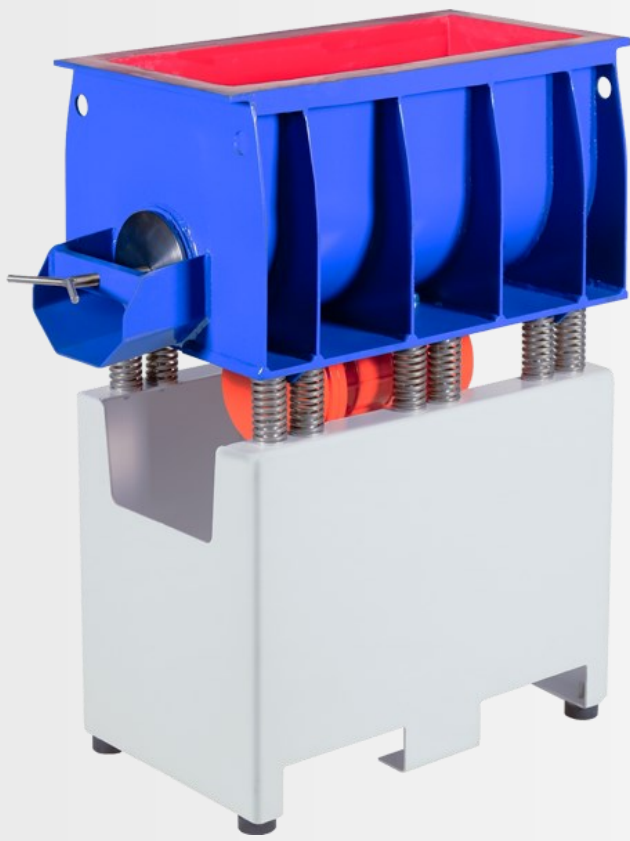

Trough Vibrators TV

- Universally applicable in numerous application scenarios
- Compact design with a large work tank
- Numerous accessory options
- Particularly inexpensive, even if only used occasionally
- Abrasive media can be changed quickly
- Contactless grinding possible through partition walls

Compact and universal

Trough vibrators are characterized by their compact design and universal application. Thanks to their U-shaped worksheets, even very large workpieces can be processed in systems with a small total volume. The vibration motor attached directly to the underside of the work container drives the vibratory grinding system particularly effectively, which means that trough vibrators work particularly efficiently. Our TV trough vibrators convince with an advantageous price-performance ratio and offer an ideal machine platform for a variety of applications within vibratory grinding technology.

That's how it works

In the case of trough vibrators, the workpieces and the abrasive are placed loosely in the working container as a bulk material. In the case of sensitive workpieces, the components to be machined are either fixed by special clamping devices or machined in separate chambers in order to avoid damage during machining. The use of partitions also makes it possible to process completely separate batches at the same time in one machine.

The all-rounder among the
vibratory finishing machines



Areas of application:

- Deburring, smoothing and polishing
- Descaling, derusting and cleaning
- Rounding contours, edges and corners
- General finishing of surfaces

Advantages:

- Wiper edge to reduce component build-up on the inside wall of the container (standard or optional, depending on the size)
- Particularly economical even if only used occasionally
- Optionally available as a version for pressure deburring and ball polishing
- Robust construction with a low-maintenance vibration motor
- Integrated holder for lifting and moving the system using a lift truck or forklift truck
- Quick emptying of the container and changing of abrasives thanks to a large drainage opening for abrasives
- Quick-change drainage screen made of polyurethane
- Rubber-cushioned feet to reduce the transmission of vibrations

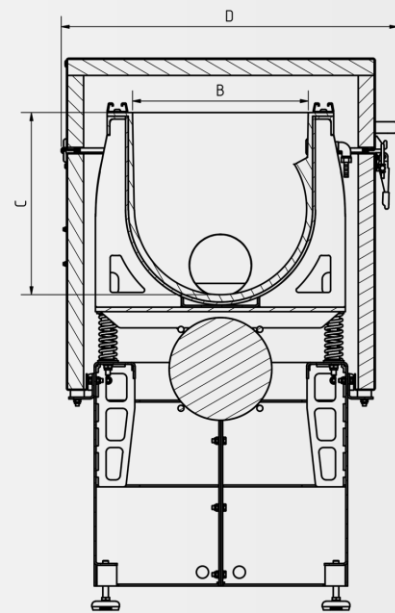
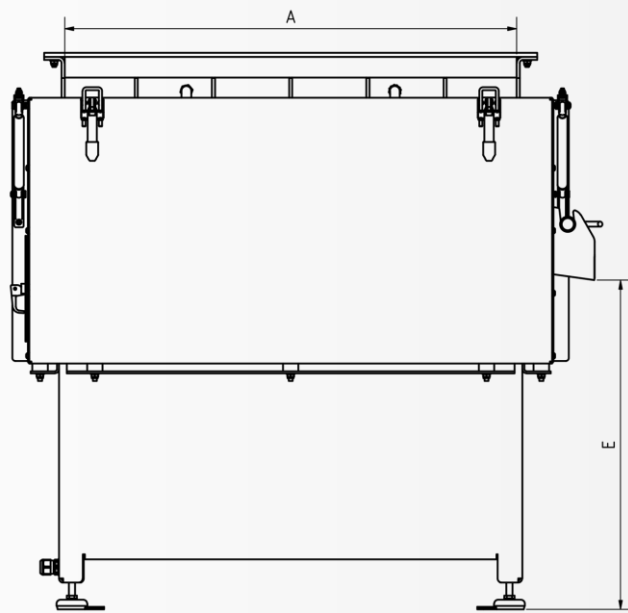

		TV15	TV25	TV45	TV55	TV73	TV85	TV95
Volume (gross)	liter	27	50	115	275	470	840	1740
Usable volume	liter	18	36	95	230	400	740	1550
Drive power max.	kW	0,35	0,5	1	2	4	7,5	11,5
Inside length working container (A)	mm	500	600	850	1200	1100	1500	2000
Inner width work container (B)	mm	215	275	375	480	680	780	980
Interior height of the working container (C)	mm	270	325	395	520	700	840	1000
Output height (E)	mm	630	630	630	630	630	590	590

Also available as an extended version and in other sizes on request.

Equipment:

- Drive with variable speed control (frequency controlled)
- PLC controlled electrical switchgear for partially and fully automated plant operation
- Infinitely adjustable partitions to divide the work container into several chambers
- Clamping systems for fixing workpieces
- Dosing systems for process media and additives
- Sound insulation concepts such as sound insulation covers, housings, ... (pneumatically or manually operated)
- Extended process water management concepts (ring showers, distributor nozzles, rinsing systems, washing nozzles, ...)
- Sieving systems for the separation of workpieces and grinding media
- Universally screw-on and thus changeable discharge chutes
- Wiper to avoid component build-up on the container wall (available lengthways and frontal side)
- Ball polished version



Mobile Tumbler TV-M

- Mobile vibratory grinding system with integrated treatment of process fluids
- Integrated sieve box for separating the workpiece and grinding tools
- Compact design for large work containers including soundproofing
- Plug & Play System: Connect the 230V power supply and get started

Mobile and universal

Trough vibrators are characterized by their compact design and universal application. Their U-shaped worksheets allow very large workpieces to be machined relative to the size of the system.

The TV-M model is unique in that all components that are required for vibratory grinding are compactly and mobile mounted on a trolley. An integrated cascade cleans the process liquid, workpieces can be separated by means of a sieve box and various grinding tools can be stored in slide-in compartments.

Advantages:

- Mobile use: all components integrated in one trolley
- Plug & Play: Connect the 230V power supply and get started. (Schuko plug)
- Quiet operation thanks to complete soundproof housing
- Integrated electrical control for process monitoring including timer (timer)
- Including frequency-controlled speed control as standard
- Quick-change sieve device for separating workpieces and grinding media
- Integrated process water treatment through a 3-stage cascade

The mobile trough vibrator for slide grinding



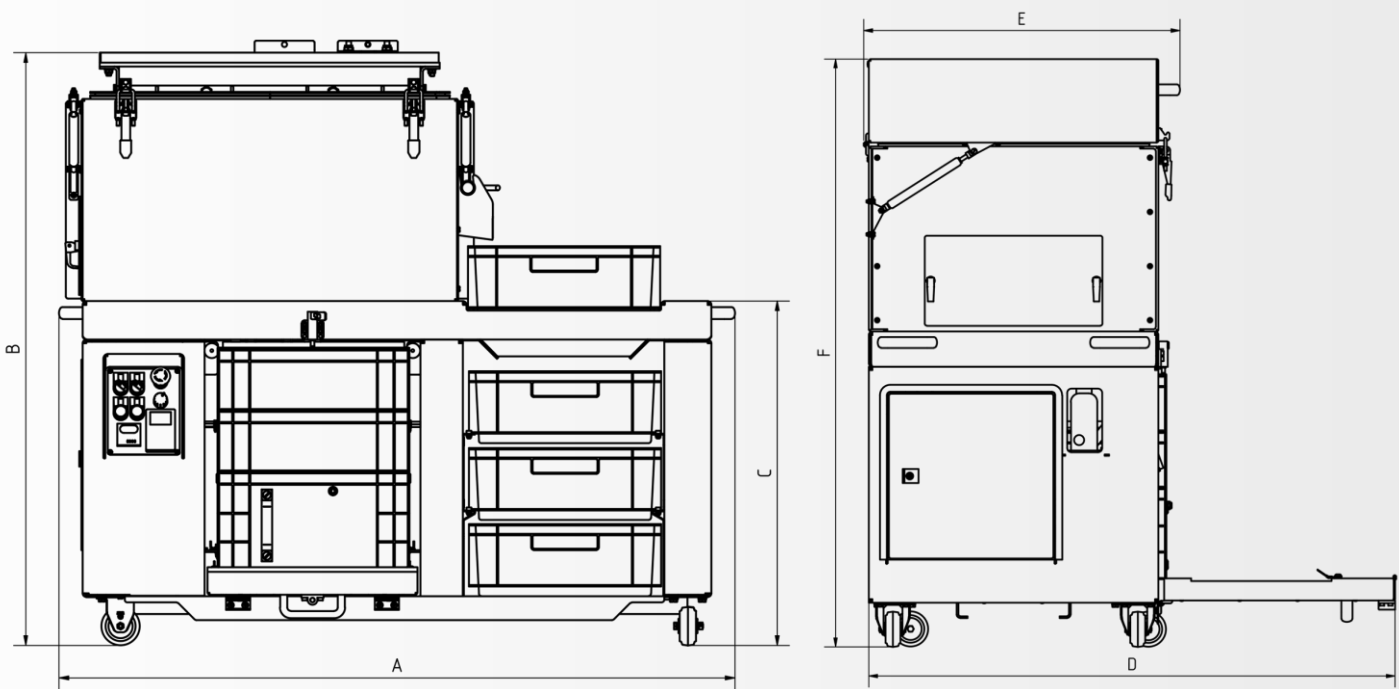

		TV15-M	TV25-M
Volume (gross)	Liter	27	50
Usable volume	Liter	18	36
Connected load (series)	kW	0,5	0,75
Inside length working container	mm	500	600
Inner width work container	mm	215	275
Interior height of the working container	mm	270	325
Total length of the trolley (A)	mm	1450	1450
Trough vibrator removal height (B)	mm	1240	1240
Table height trolley (C)	mm	720	720
Width with the lid open (D)	mm	1200	1200
Wide carriage (E)	mm	730	730
Total height (F)	mm	1400	1400

Equipment:

- Infinitely adjustable partitions to divide the work container into several chambers
- Automatic replenishment for process media and additives (compound)
- Extended process water management concepts (ring showers, distributor nozzles, rinsing systems, washing nozzles, ...)
- Sieves for separating workpieces and grinding media in different perforations. Various sieve boxes available in standard and special perforations.
- Clamping systems and devices for fixing workpieces
- Customizations

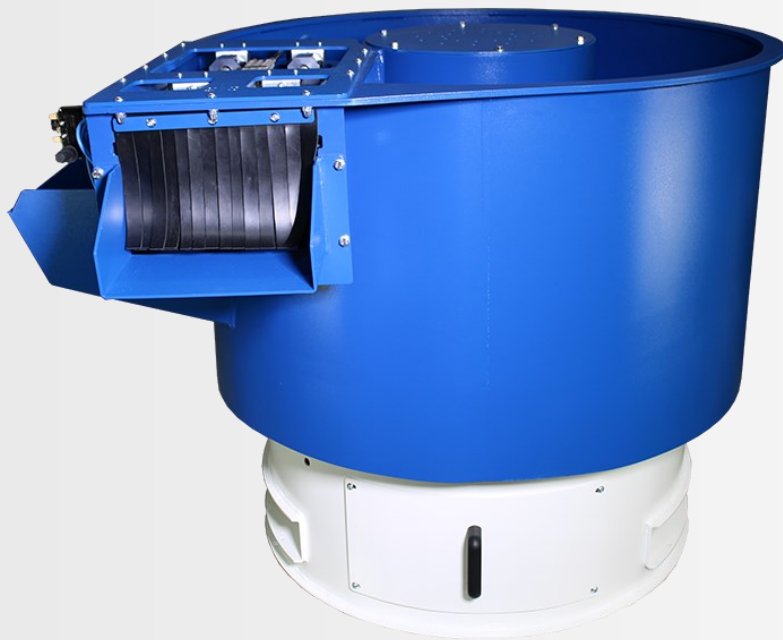

Rotary Dryer RT

- Spot-free component drying using drying granules
- Energy-efficient direct heating of the work container
- Spiral and gently rising container bottom
- Integrated separating sieve
- Either continuous or batch operation is possible

Energy-saving and powerful

Since a process fluid is usually used in vibratory grinding, the workpieces are contaminated with it and must be cleaned or dried at the end of the process. Either hot air or special drying media are used to dry the components. For this purpose, the workpieces are placed in a container in a rotary dryer, in which there is a heated medium for drying. For this purpose, nut or corncob meal is usually used in rotary dryers.

Areas of application:

- Spot-free component drying directly after the mass finishing process
- Repolishing of components to improve the surface
- Fine machining of particularly difficult contours
- Prevention of rust film thanks to completely dry surfaces
- Efficient drying of complex geometries
- Can be used for special processes such as the de-oiling of components, ...

For efficient component drying
after mass finishing

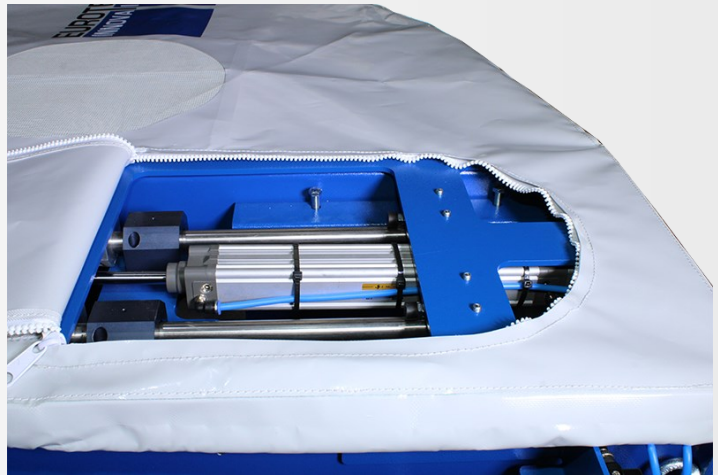
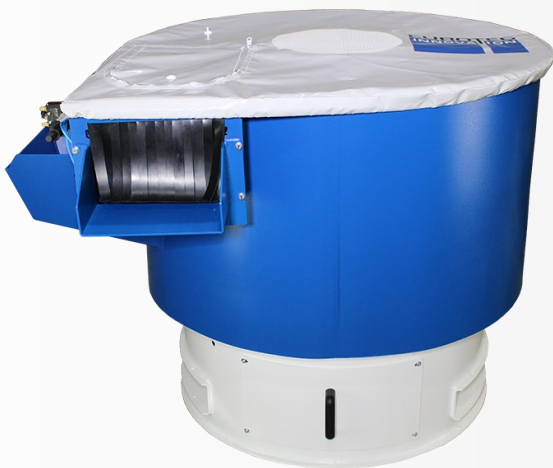
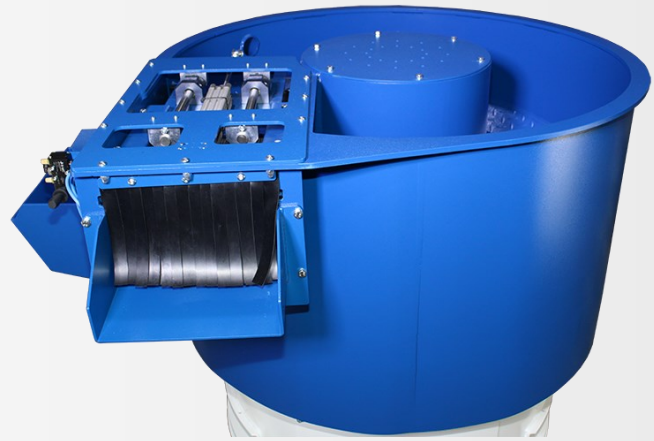
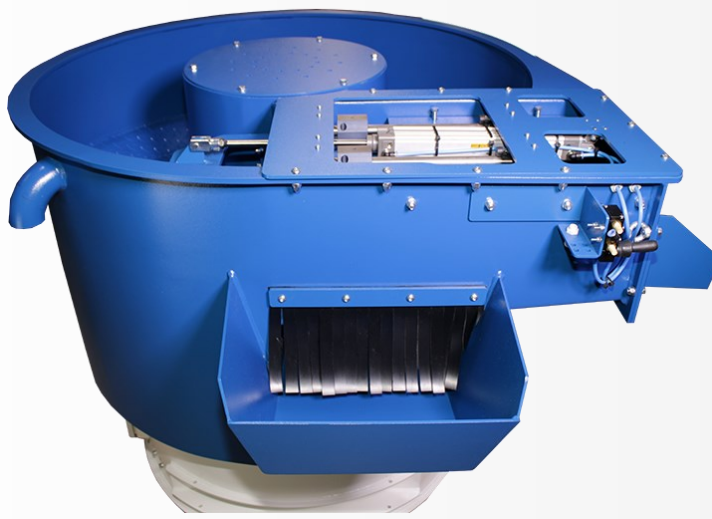

Advantages:

- Economic and fast drying of components after vibratory grinding
- Energy-efficient direct heating for energy-saving operation with minimal energy loss
- Optionally available with increased heating power for faster heating-up times
- Achieving stain-free surfaces through the use of drying granules such as corn meal
- Drying and polishing of the workpieces in one operation
- Integrated screening section for efficient workpiece separation
- Optionally switchable between batch and continuous operation using a built-in slide (optionally with pneumatic actuation)
- Hopper bottom rising in a spiral shape with a corrugated bottom for gentle processing with a flat and spiral shape rise
- Modular, changeable sieve inserts and delivery chutes
- Possibility to connect to dust extraction systems is available as standard

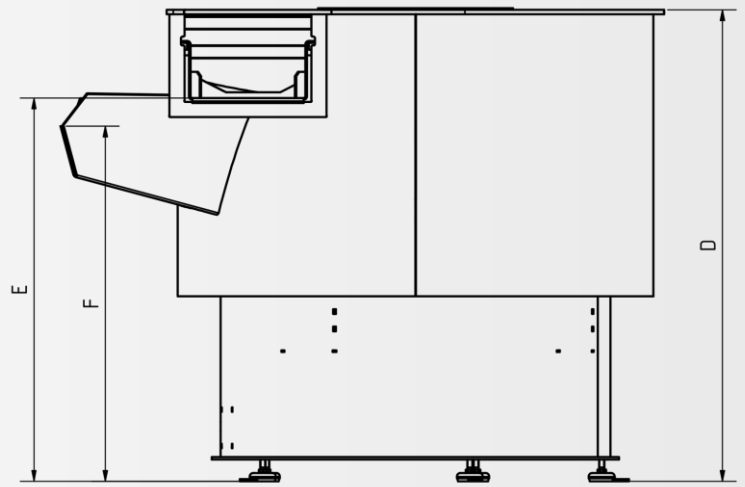
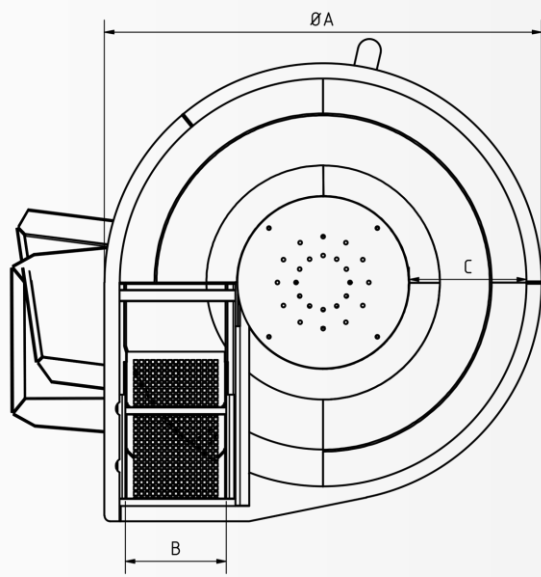

		RT20	RT27	RT37	RT41	RT55
Gross volume	Liter	150	270	580	850	1600
Usable volume	Liter	80	140	350	450	750
Drive power	kW	1,6	1,6	1,9	2,5	5
Max. Heating power	kW	3	4	6	10	14
Outer diameter (A)	mm	1050	1200	1650	1900	2200
Wide sieve area (B)	mm	250	330	450	500	670
Channel width (C)	mm	250	330	450	500	670
Total height* (D)	mm	1050	1100	1250	1350	1400
Output height* (E)	mm	820	850	900	950	1000
Height * feed (F)	mm	820	850	950	980	1050

*Custom height adjustment possible.

Equipment:

- Pneumatically operated slide for changing from batch to continuous operation
- Cover as dust protection and for thermal insulation (dust protection cover)
- Dust extraction systems (dust extractors)
- Sound insulation concepts to minimize noise emissions
- Increased heating power for shorter heating times
- Drive with variable speed control
- PLC controlled electrical switchgear for partially and fully automated plant operation
- Thermostat regulated temperature control
- Universally adaptable delivery chutes
- Wear and impact protection coatings
- Delivery chutes for linking in plant parks
- Sieves for separation with different perforation sizes and with protective coatings to minimize noise and component damage



Centrifuges ZS PE

- Efficient treatment of process fluids through high centrifugal forces
- Different sizes exactly suitable for your application
- High throughput rates enable several systems to be supplied at the same time
- PLC controlled and monitored cleaning process
- Process water management

Environmentally friendly and powerful

There are numerous applications in industrial production in which large quantities of contaminated process fluids are produced. If these liquids are processed and run in a continuous cycle, costs are avoided and the environment and resources are sustainably protected.

Our centrifuges with exchangeable sludge insert of the ZS series are characterized by their high cleaning performance. Thanks to the modular concept consisting of a centrifuge attachment and a substructure, the system can be precisely adapted to your customer requirements. There is a choice of process water tanks with different capacities for both dirty and clear water.

ZS centrifuges are particularly user-friendly, as a PLC control monitors and controls the entire system. The status of the system is shown on a display. The process water management system independently monitors fill levels and communicates with coupled systems. With an exchangeable sludge insert, the discharged and dried solids can be removed and disposed of economically and easily.

To cycle management of process fluids

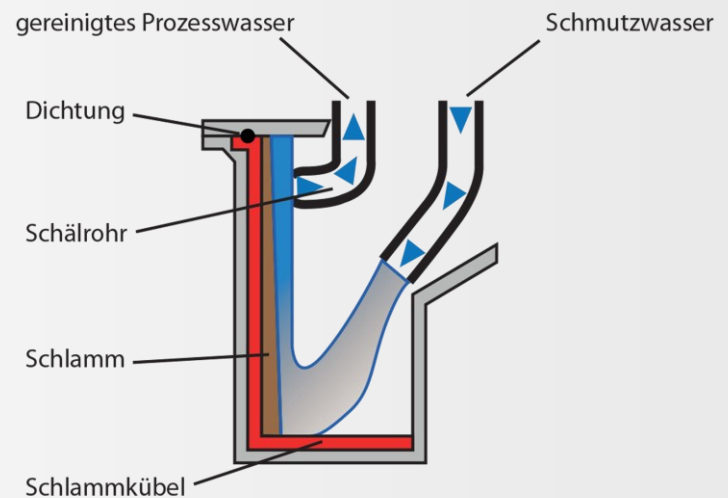
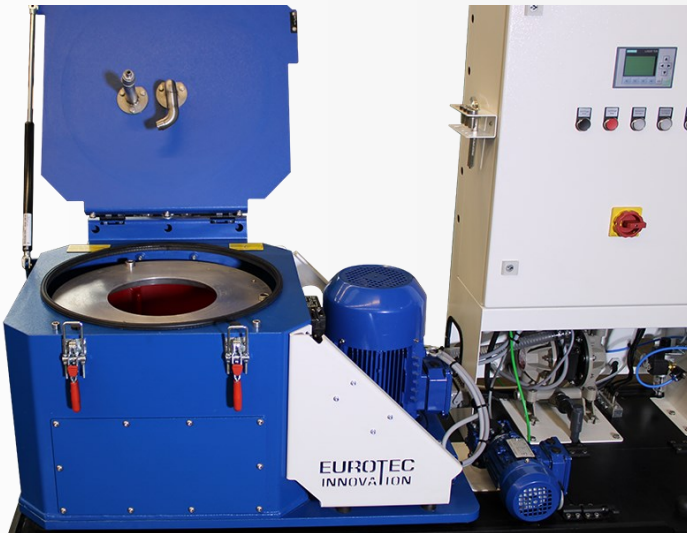

Advantages:

- High discharge through acceleration forces of around 2000 times the acceleration due to gravity (depending on the model)
- Guiding the process water in a cycle, which minimizes operating costs and protects the environment
- Saving of expensive additives for the mass finishing process (compound)
- Economical and efficient separation of solid particles from a mixture
- Designed for continuous operation with high availability
- Complete process water management in one system (buffer storage, pressure pumps, automatic level monitoring and refilling, ...)
- Supply of several systems at the same time with only one ZS centrifuge through optionally available additional buffer storage for clear water
- Suitable for process liquids up to 70 ° C (optional cooling available)

Areas of application:

- Preparation of vibratory finishing process fluids
- Purification of mixtures (suspensions and emulsions)
- Processing of phosphating, painting, washing and oil baths
- Processing of cooling lubricants (KSS)
- Processing of coolants from saws, milling machines and lathes
- General separation of solids from liquid mixtures

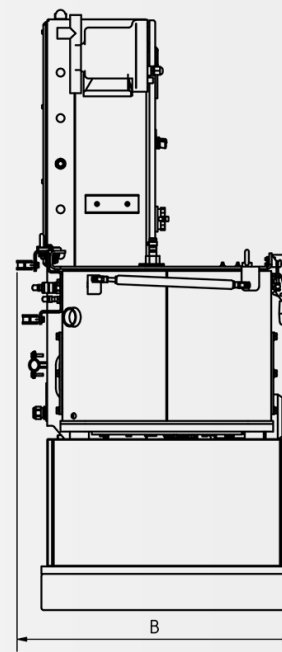
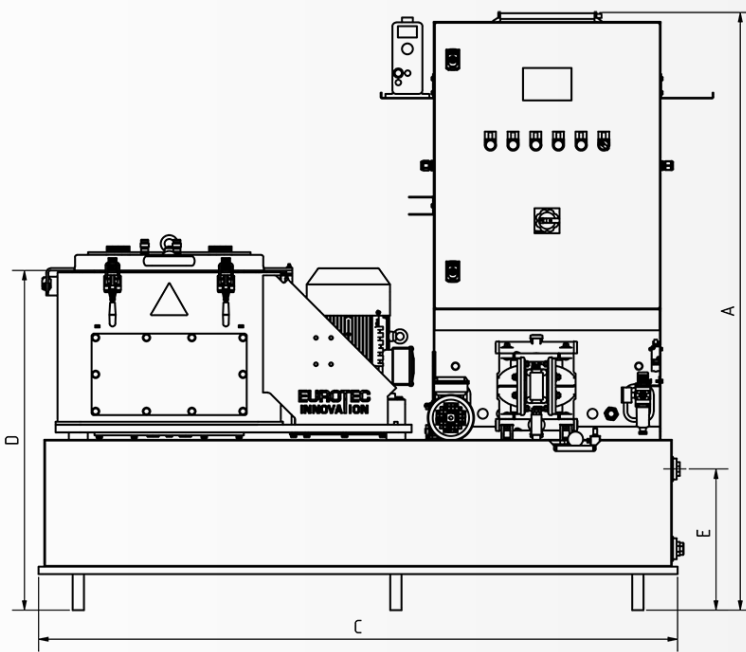

		ZS21 PE	ZS38 PE
Nominal cleaning performance	liter/h	800	1400
Max. Amount of sludge per change cycle	liter kg	3,5 5,5	15 22
Max. Rated speed	RPM	4160	2900
Max. Acceleration	g	2070	1810
Drive power	kW	1,5	4
Medium electr. Performance in operation	kW	1,0	2,5
Inside diameter drum	mm	210	380
Volume of dirty water tank (SW)	liter	200	200
Clear water tank volume (KW) (optional)	liter	20/40/300/500	20/40/300/500
Total height (A)	mm	1580	1580
Overall width (B)	mm	700	700
Overall length (C)	mm	1706	1706
Removal height sludge insert (D)	mm	800	910
Height of waste water return (E)	mm	375	375

Equipment:

- Various container sizes as buffers for process liquids made of PE, PP, stainless steel
- Modular, expandable clear water tank (KW) with different volumes
- Pressure pumps for the simultaneous supply of process water to several systems
- Auxiliary pumps and lifting systems for sucking in liquid from external containers
- Collecting trays for substances hazardous to water (WHG collecting tray)
- Filter and sieve systems for the pre-cleaning of process liquids
- Automatic level monitoring and refill dosing devices
- Automated dosing devices for additional media (flocculants, compounds)
- Electronic coupling with a system park



Compact Centrifuges ZS EUR

- Compact structure with full range of functions
- Optionally with an integrated storage tank for clear water
- High cleaning performance thanks to efficient solid-liquid separation
- Plug & Play: ready for use in just a few minutes
- PLC controlled and monitored cleaning process

Compact and versatile

Based on the modular principle, the compact centrifuges ZS EUR consist of the standard centrifuge attachment and a compact buffer tank. The tank is optionally available with a split container and also serves as a substructure. Thanks to the compact design, this series offers the full range of functions of a cleaning centrifuge with a wide range of uses.

Advantages of the ZS EUR centrifuges:

- Compact structure with integration of all components (buffer storage, switchgear, agitator, pump units, ...)
- Easy transport and commissioning
- Particularly inexpensive thanks to standardization
- Optionally available with a split process water tank: separate waste and clear water tank for maximum flexibility
- Easy access for maintenance and cleaning of the tank

Compact centrifuges for
highest demands.

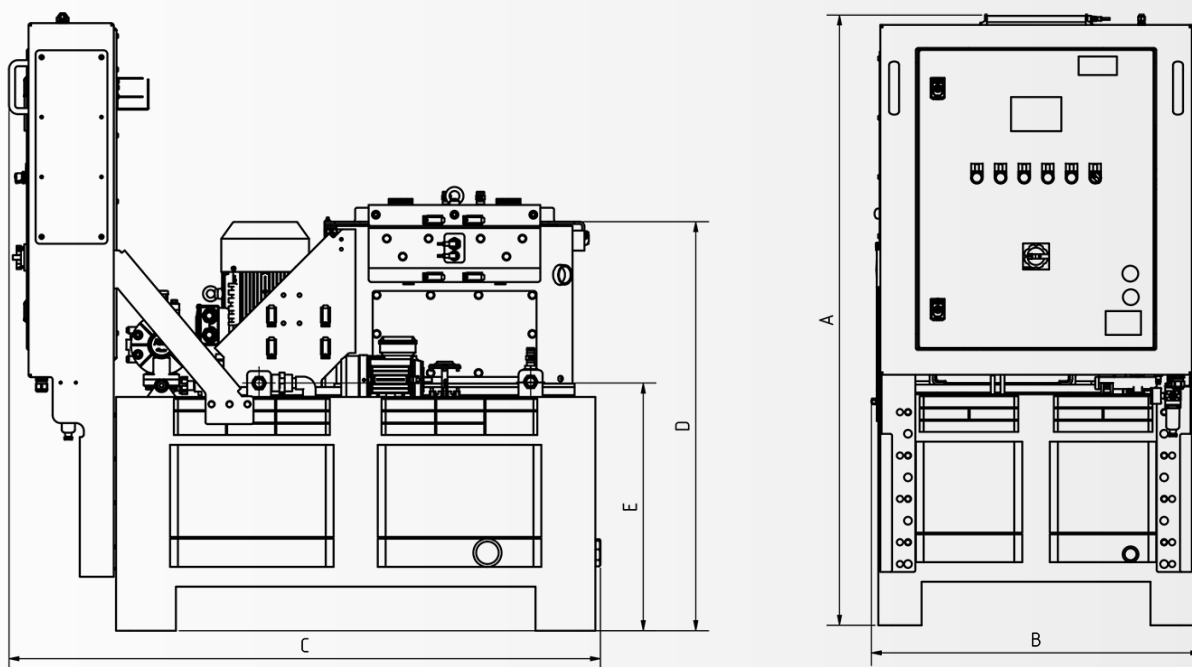

		ZS21 EUR	ZS21 EUR KW	ZS38 EUR	ZS38 EUR KW
Rated capacity	liter/h.	800	800	1400	1400
Max. Amount of sludge per change cycle	liter kg	3,5 5,5	3,5 5,5	15 22	15 22
Max. Rated speed	RPM	4160	4160	2900	2900
Max. Acceleration	g	2070	2070	1810	1810
Drive power	kW	1,5	1,5	4	4
Medium electr. Performance in operation	kW	1,0	1,0	2,5	2,5
Inside diameter drum	mm	210	210	380	380
Volume of dirty water tank (SW)	liter	225	110	225	110
Clear water tank volume (KW)	liter	optional (external)	80 (integrated)	optional (external)	80 (integrated)
Total height (A)	mm	1550	1550	1550	1550
Overall width (B)	mm	835	835	835	888
Overall length (C)	mm	1490	1490	1490	1490
Removal height sludge insert (D)	mm	915	915	1025	1025
Height of waste water return (E)	mm	620	620	620	620

Equipment:

- Auxiliary pumps and lifting systems for sucking in liquid from external containers
- Automated dosing devices for additional media (flocclants, compounds, ...)
- Housing and drum made of stainless steel
- Electronic coupling with a system park
- Modular, expandable clear water tank (KW) with different volumes
- Numerous control options to increase the degree of automation



Illustration: ZS21-M with EUR tank

Mobile Centrifuges ZS-M

- Mobile cleaning centrifuge for the flexible treatment of process liquids
- Flexible use
- Plug & Play: ready for use in just a few minutes
- Efficient solid-liquid separation through high centrifugal forces
- PLC controlled and monitored cleaning process

Mobile and powerful

Contaminated process fluids arise in many processing machines in industry. In some cases, however, the amount of dirt that occurs is only small, which is why a separate treatment plant is not economical for this. A mobile cleaning centrifuge, however, makes it possible for the liquids of several process systems to be treated by just one centrifuge. This saves costs and protects the environment in the long term.

Our mobile centrifuges ZS-M are characterized by their flexibility and a very compact design. The mobile substructure enables the centrifuge to be used universally and in any location. The ZS-M centrifuges are characterized by the modular concept and the availability of several sizes and buffer sizes.

For mobile processing
of Process fluids

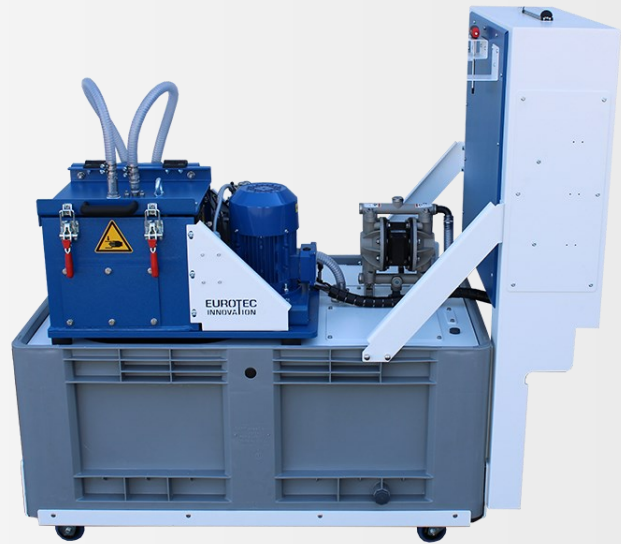
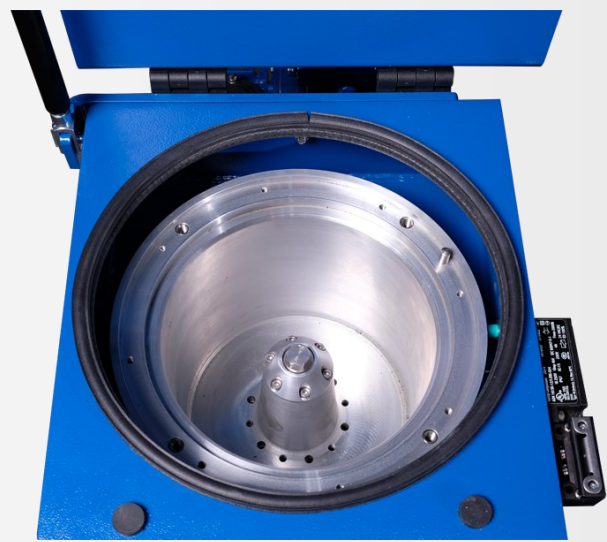
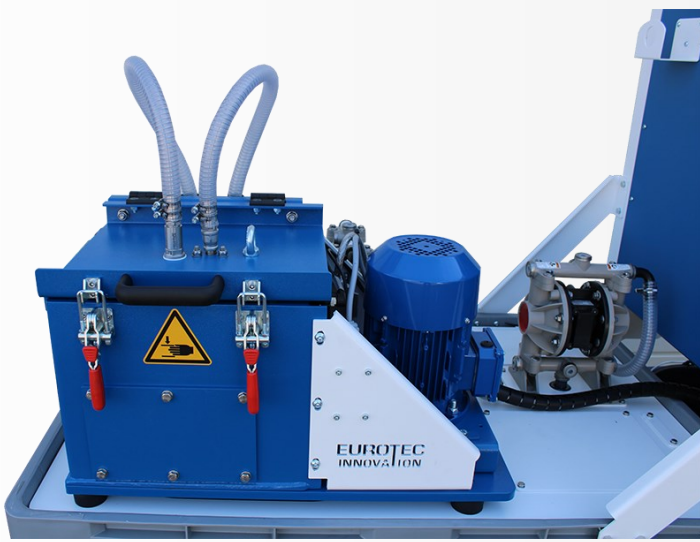

Advantages:

- Maximum mobility thanks to the integration of all components on one trolley
- Can be used flexibly thanks to its compact design
- High discharge through acceleration forces of around 2000 times the acceleration due to gravity acting in the system
- Management of the process water in a circuit, which minimizes operating costs and protects the environment
- Saving of expensive additives for the mass finishing process (compound)
- Economical and efficient separation of solid particles from a mixture
- Designed for continuous operation with high availability
- Plug & Play system: ready to use within minutes
- Cleaning liquids from multiple machines with just one centrifuge

Areas of application:

- Treatment of mass finishing process water
- Purification of mixtures (suspensions and emulsions)
- Processing of phosphating, painting, washing and oil baths
- Processing of cooling lubricants (KSS)
- Undersize grain discharge with wet blasting
- General separation of solids from liquid mixtures
- Cleaning of baths and storage tanks of third-party systems

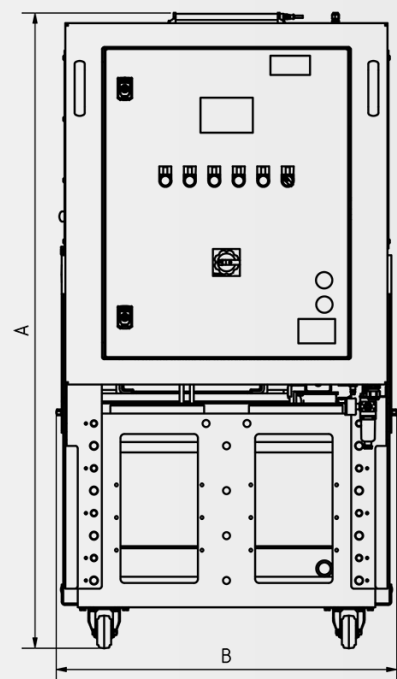
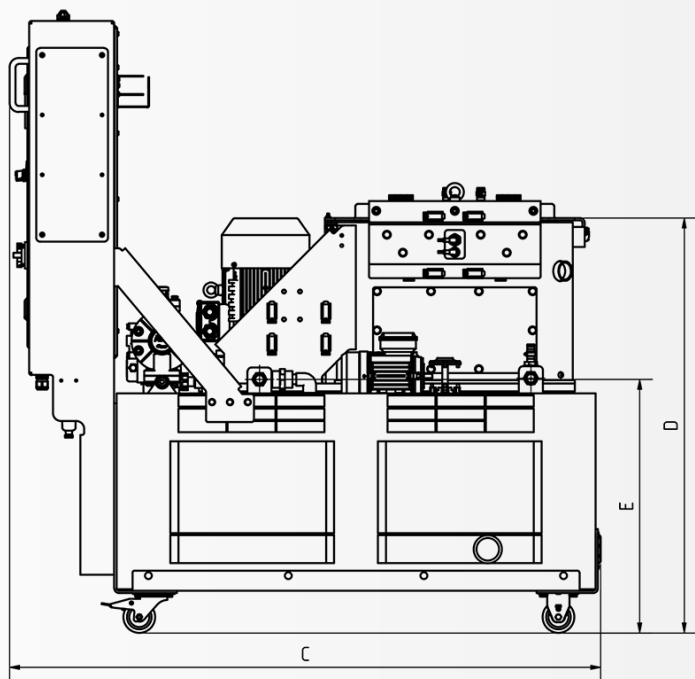

		ZS21-M EUR	ZS21-M EUR KW	ZS21-M KW A2	ZS38-M EUR	ZS38-M EUR KW
Material container	-	PE	PE	stainless steel	PE	PE
Maximum throughput	liter/h	800	800	800	1400	1400
Max. Amount of sludge per change cycle	liter Kg	3,5 5,5	3,5 5,5	3,5 5,5	15 22	15 22
Rated speed	RPM	4160	4160	4160	2900	2900
Max. Acceleration	g	2070	2070	2070	1810	1810
Drive power	kW	1,5	1,5	1,5	4	4
Medium electr. Performance in operation	kW	1,0	1,0	1,0	2,5	2,5
Inside diameter drum	mm	210	210	210	380	380
Volume of dirty water tank (SW)	liter	225	110	100	225	110
Clear water tank volume (KW)	liter	-	80	90	-	80
Total height (A)	mm	1560	1560	1345	1560	1560
Overall width (B)	mm	835	835	780	835	890
Overall length (C)	mm	1490	1490	1125	1490	1490
Removal height Mud insert (D)	mm	930	930	850	1040	1040
Height Dirty water return (E)	mm	635	635	534	635	635

Equipment:

- Auxiliary pumps for drawing in liquid from external containers
- Storage tank for the external provision of process fluids
- Agitator for improved solids discharge
- Automatic dosing devices for compounds and flocculants
- Electronic coupling with a system park

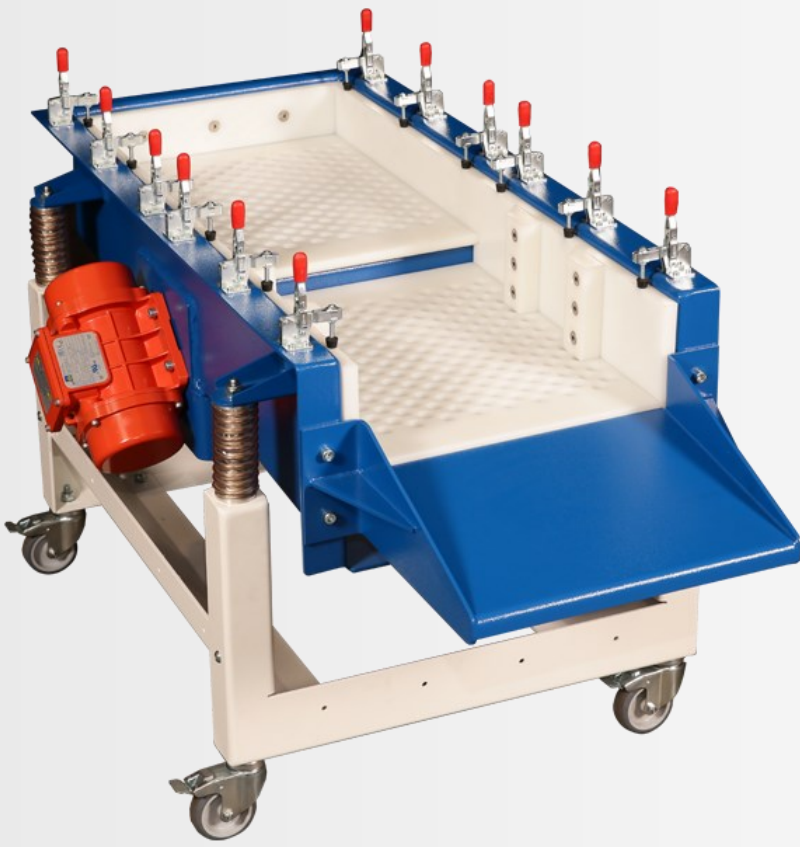

Separations WS

- Economic separation of workpieces and grinding media
- Can be modularly combined with many vibratory finishing systems
- Quick-change sieve inserts for a wide variety of grinding tools
- Mobile use thanks to castors
- Adaptable to a wide variety of vibratory finishing systems

Economical and mobile

For the efficient and economical separation of grinding medium and workpieces, our machines for separation offer maximum performance in a compact design. Can be used flexibly and extremely mobile thanks to lockable swivel castors.

Advantages:

- Semi-automatic operation through two unbalance motors
- Economical separation of workpieces and grinding tools, even with larger quantities
- Quick-change sieve plates thanks to a tool-free quick-release system
- Integrated fall steps for improved sieving
- Sieve surface completely lined with plastic to reduce damage to components during the sieving process
- Various delivery chutes are exactly the right one for every application

For economic and
mobile separation

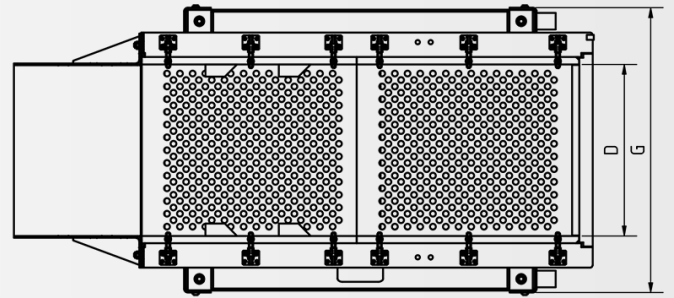
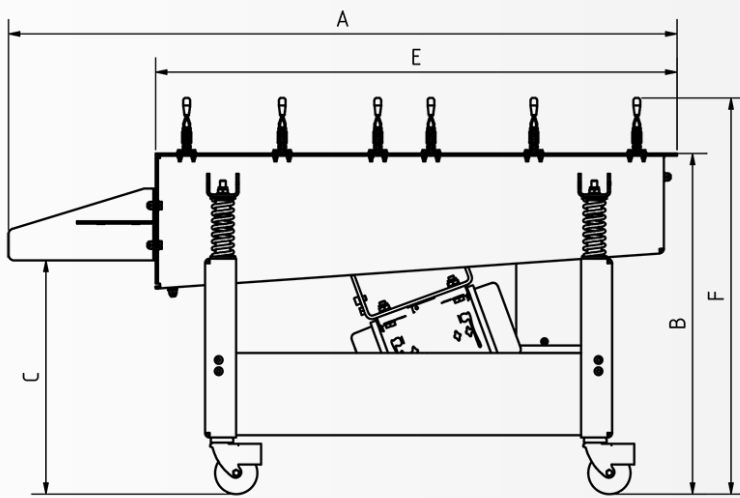

		WS25	WS27	WS35	WS45
Drive power	kW	2 x 0,12	2 x 0,16	2 x 0,16	2 x 0,35
Height of component feed* (B)	mm	610	650	610	610
Output height* (C)	mm	420	420	420	420
Wire width (D)	mm	350	350	500	600
Screen length (E)	mm	880	1320	1200	1400

*Custom height adjustment possible.



Illustration: TV45 with WS25

Equipment:

- Drive with variable speed control (frequency converter)
- Sieve plates with a wide variety of perforations depending on customer requirements
- Delivery chutes in various designs and lengths
- Integrated screening of undersize (undersize)
- Wipers, throttle slide, flushing wreaths and drop steps for improved separation
- Electronic coupling within a system park



Process media Abrasive media

- Numerous different sizes and grind levels available
- Exactly suitable for your process
- Numerous chemicals for the vibratory finishing process
- Granules for efficient drying
- Abrasive pastes and cleaning agents
- Flocculants and process water additives

For details see special magazine

Choose from a wide portfolio of process media for your grinding or machining process. A wide variety of grinding tools in different sizes and geometries are available. Liquid chemical additives (compounds) are just as important for a high-quality vibratory grinding process as is the drying of components at the end of the grinding process.

Abrasives:

- Ceramic grinding media
- Plastic abrasives
- Special media for polishing and high-gloss compression (porcelain, stainless steel, ...)

Granules for component drying:

- Corn meal
- Nut scrap

Compounds and additives for process water technology

**100% tailored to your
Machining process**

EUROTEC INNOVATION

**Mass Finishing
Effluent Treatment
Grinding Technology
Abrasives
Edge Rounding
Special Machine Construction**

Eurotec Innovation GmbH

Am Kögel-Werk 18
89349 Burtenbach
Germany

phone: +49 (0)8285 92825-100
info@eurotec-innovation.com
www.eurotec-innovation.com

Your dealer:



All rights reserved. No liability for printing errors, errors excepted. Errors and technical modification subject to change, reproduction as well as duplication only with our written permission. DV-010 V3.0-EN

