

Ech: 1/10

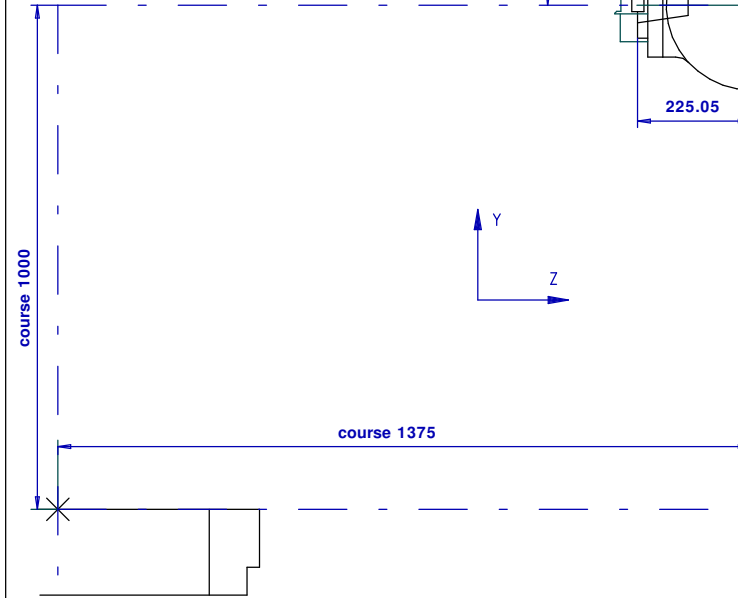

Ech: 1/20

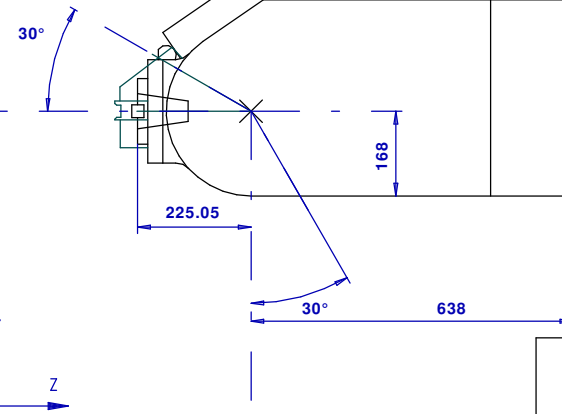
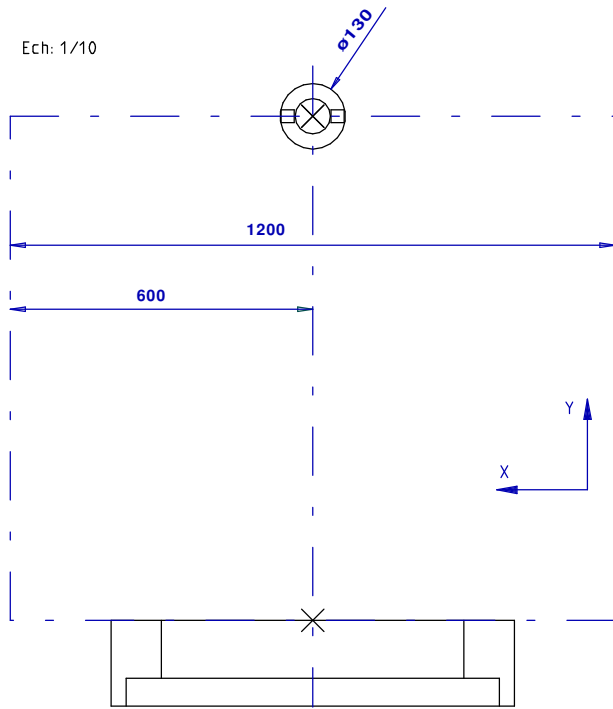
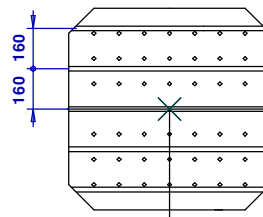

OUTILS	MAGASIN	: 116 outils
	Ø MAX outil	: 125 mm
	Ø MAX 3Trous	: 320 mm
	POIDS MAXI	: 25 Kgs
BROCHE	CONE	: SA 50
	PUISSANCE	: 17 Kw
	ARRDS CENTR	: .
	VITESSE	: 2-839/840-4000
TABLE	POSITIONS	: 360000
	SURFACE	: 800 x 800
	Ø CENTRAGE	: Ø80H7
	FIXATIONS	: 42 TROUS M16
	ENTRAXE	: ENTRAXE 100
TEMPS	RAINURES	: 5 de 18H7/H12
	CHGT OUTIL	: .
	BO . B180	: .

Ech: 1/10
et Ech: 1/20

HM

761
FOREST FLEXIAX 508
armoire FANUC 15M



BE1/MACHINES/CARACT_MAC/761