

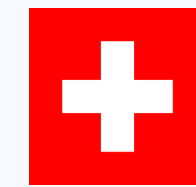

SWISS
MADE



technica
technology gmbh

ROTAFLEX

CNC ROTARY
TRANSFER MACHINES





LISTS OF CONTENT

1. About Us
2. Overview
3. Rotaflex DV Series
4. Rotaflex RT Series
5. Stemoflex Series
6. Rotary Tables
7. Modules
8. Operations
9. Technologies
& Technics
10. Accessories
11. Refurbishing
& Remastering

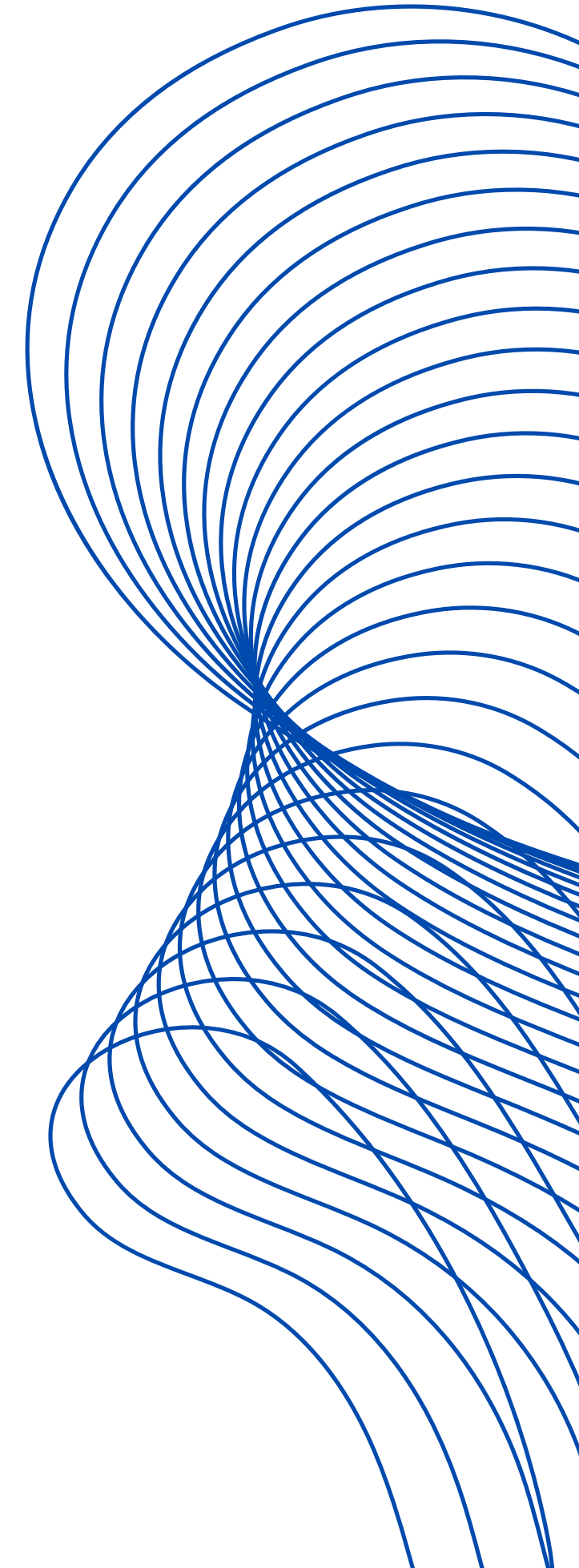

01

ABOUT US



Founded in 1941, Technica has led the mass-production sector with its rotary transfer machines known for their flexibility. Technica developed the most flexible rotary transfer machine with the Rotaflex Series CNC Rotary Transfer Machines, which can perform simultaneous processing on up to 5-axis and turning up to 6,500 rpm. Today, the Rotaflex Series remains the favorite of manufacturers who require high precision and high capacity for complex workpieces.

Hundreds of Technica machines, made with Swiss precision and quality, are still operating at well-known customers' even after more than 50 years.



sec./pcs.



sec./pcs.

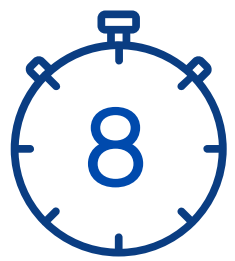

sec./pcs.



sec./pcs.

OVERVIEW

In Rotaflex CNC Rotary Transfer Machines, all processes such as drilling, milling, turning, threading, and others—are divided among up to 14 different stations. Each station uses single or double spindles capable of 5-axis machining or turning at speeds up to 6,500 rpm.

The total cycle time for each workpiece is calculated as the longest and indivisible process plus the table rotation time.



=



+



+



+



+





**SWISS
MADE**

03

ROTAFLEX

DV SERIES



Featuring Technica's revolutionary TWS Pallet System, simultaneous B-axis workpiece rotation, and turning up to 6,500 rpm, the Rotaflex DV Series is the most flexible rotary transfer machine in its class.

The Rotaflex DV Series, with each module capable of X, Y, Z, +B, and +A axis movements, also supports U-axis processes using Mapal Recessing Heads.

With the Plug & Run Chucks offered by the Technica Pallet Transport System, each chuck can be replaced in less than 2 minutes. Additionally, with HSK C-type tool holders, each tool can be replaced in less than 1 minute.

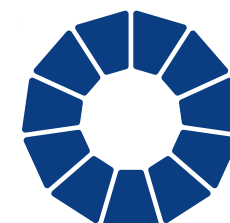

up to
15 Stations



up to
28 Spindles



up to
5-Axis



**SWISS
MADE**

04

ROTAFLEX

RT SERIES



The Rotaflex RT Series CNC Rotary Transfer Machines, which use an indexing table, exceed customer expectations with X, Y, Z, and +A axis movement capability in each module. The Rotaflex RT Series, also supports U-axis processes using Mapal Recessing Heads.

Offering speeds up to 20,000 rpm and repeatability of less than 2 μm in each module, the Rotaflex RT Series also provides through spindle coolant up to 120 bar.

In addition to easy tool changes with HSK C-type tool holders, it also provides instant tool wear monitoring with the Nordman Tool Monitoring System.

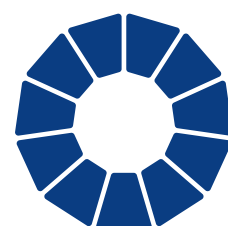

up to
12 Stations



up to
22 Spindles

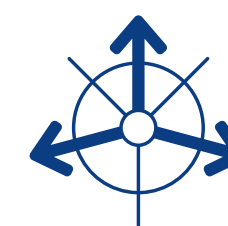

up to
4-Axis



**SWISS
MADE**

05

STEMOFLEX



For customers who want high quality and reliability for their standardized applications, we recommend our Stemoflex Series Rotary Transfer Machines. The Stemoflex Series has a simpler design compared to the Rotaflex RT and DV Series and can meet customer needs with its table featuring up to 12 stations, modules that offer movement on up to 3-axis, and B-axis workpiece positioning during station changes.

Module movements are driven by hydro-pneumatic systems or servo motors. Hydro-pneumatic systems are controlled by mechanical adjustments, while servo motor systems can be controlled PLC-based PC systems.

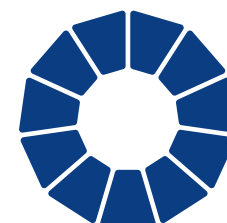

up to
12 Stations



up to
11 Spindles



up to
3-Axis



SWISS
MADE



06

ROTARY TABLES

TWS PALLET SYSTEM

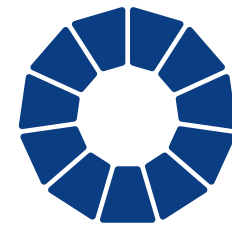

up to
15 Stations



up to
6,500 rpm



positioning accuracy
under
2 μm



indexing accuracy
under
 $\pm 3''$

In the TWS Pallet System, developed by Technica and revolutionizing the rotary transfer machine sector, workpiece holders are transported between stations. At each station, they are positioned using Hirth couplings with a position accuracy of less than $2 \mu\text{m}$ and an angular accuracy of less than $\pm 3''$.

At each station, workpieces can be rotated in 5° increments or moved simultaneously 360° around the B axis, with a precision of $\pm 20''$.

In addition, real turning is possible at speeds up to 6,500 rpm.

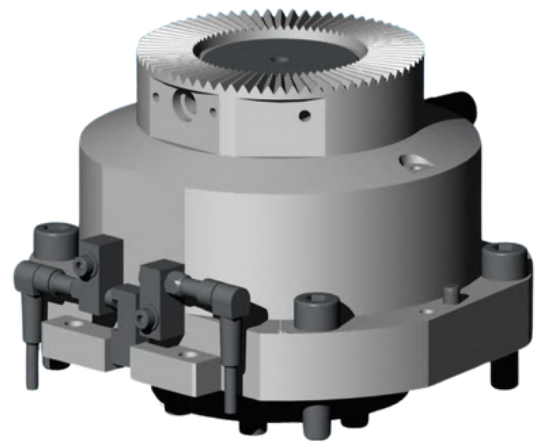

fixed
clamping

Thanks to fixed chucks, the time to change each chuck is reduced to less than 2 minutes. No screws or adjustments are required.

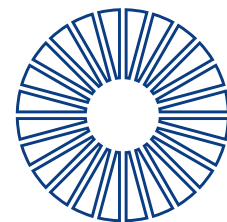
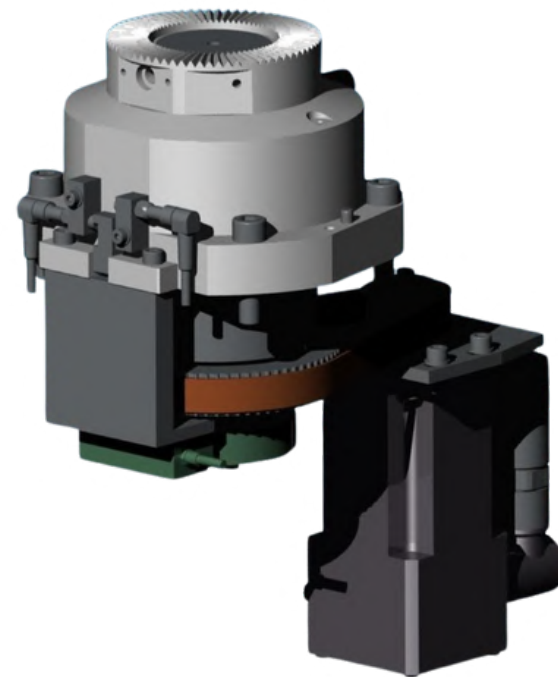

5° angular
positioning

Chucks that can rotate in 5° increments allow operations on different surfaces of the workpieces to be performed with B-axis positioning.

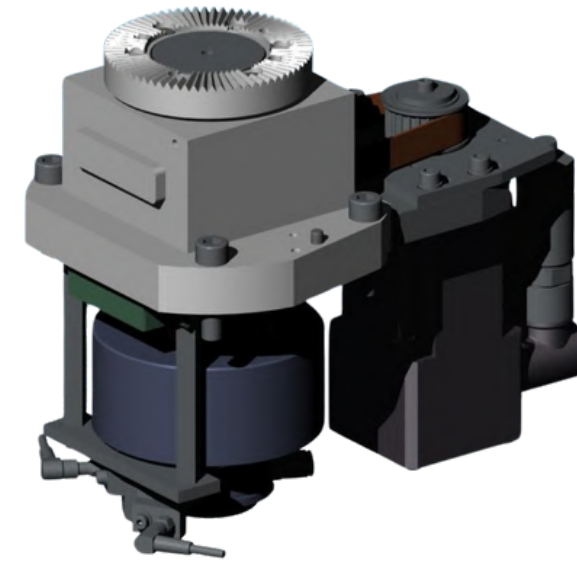

B-axis
machinig

In addition to the X, Y, Z, +A axes, B-axis simultaneous operation chucks can be used with G-code to perform B-axis operations with up to $\pm 20''$ accuracy.

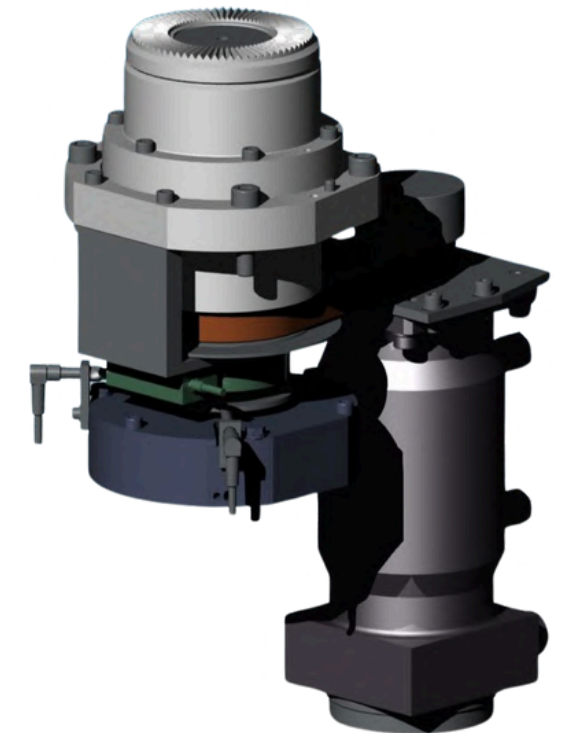

6,500 rpm
turning

We enable all turning processes with chucks that provide rotation up to 6,500 rpm. At the same time, you also have the option to use live tools or turning tools.



SWISS
MADE

06

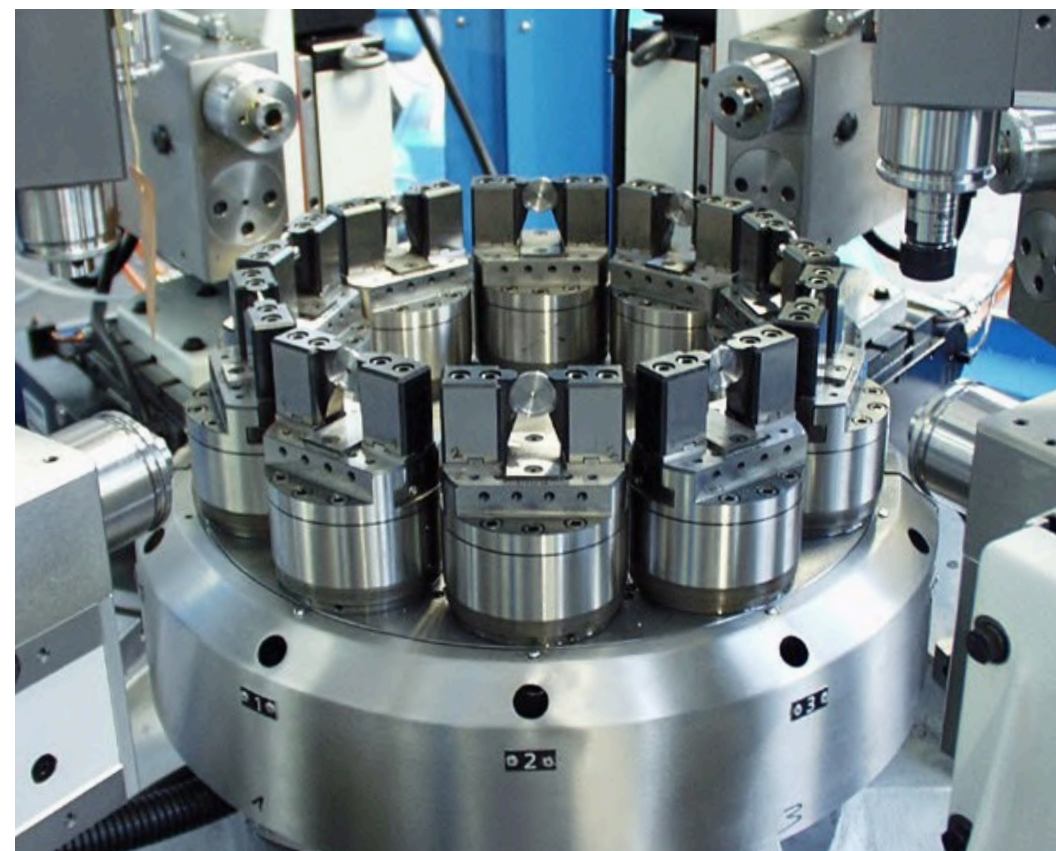
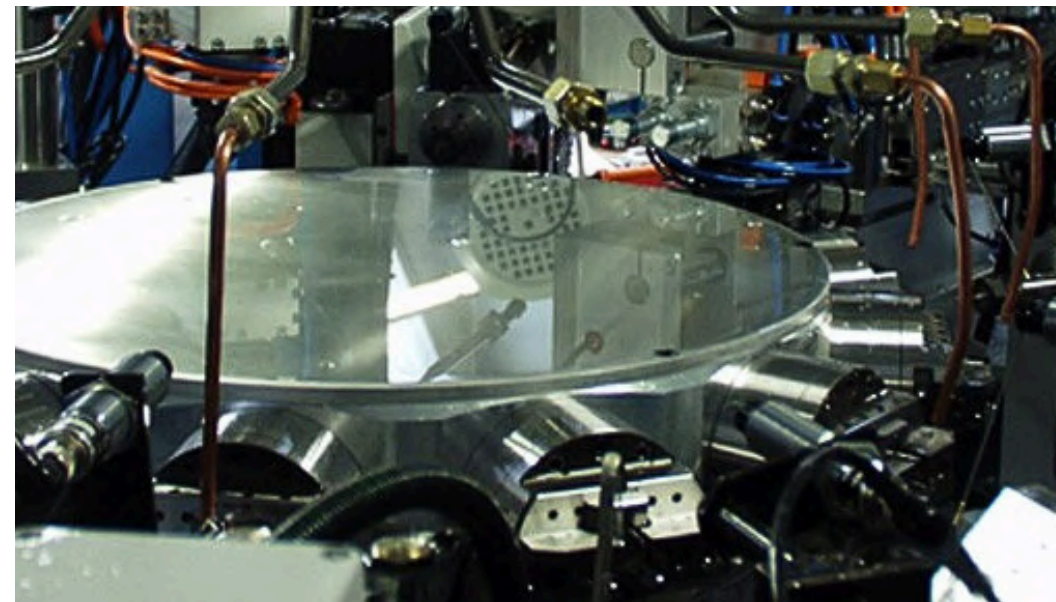

ROTARY TABLES

INDEXING TABLE

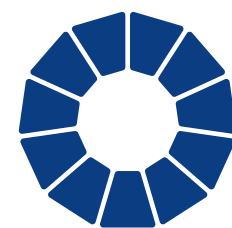

up to
12 Stations

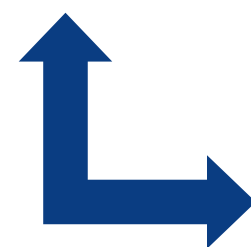

chuck direction
**vertical
& horizontal**

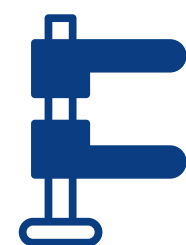

clamping
**external
& internal**

For the customers who do not need B-axis operations, we offer indexing tables that are commonly used in RTMs. Technica Indexing Tables, which provide up to 12 stations and allow chucks to be positioned horizontally or vertically, meet the capacity and flexibility requirements.

In addition to these, we can clamp workpieces with parallel chucks, three-point chucks, special workpiece holders, or expanding chucks that widen inside the workpiece.

Applications such as loosening the workpiece at certain stations or changing its position by opening and closing the chuck are also possible.



SWISS
MADE

06

ROTARY TABLES

CAM INDEXING TABLE

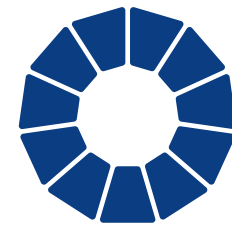
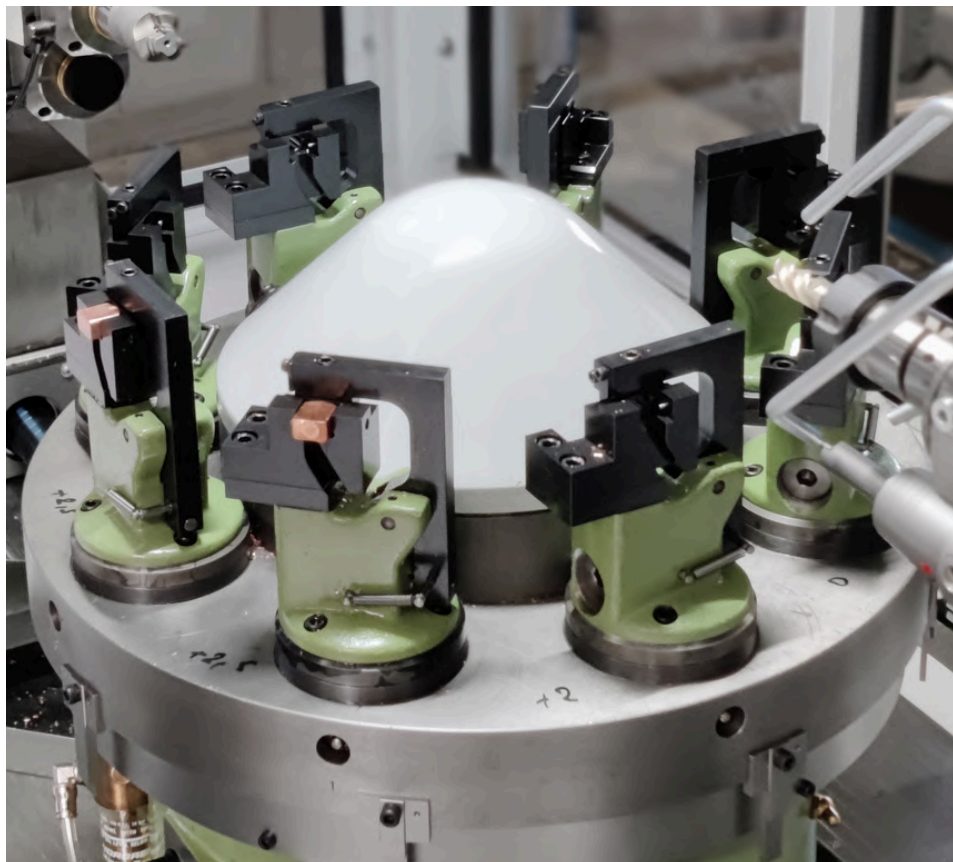
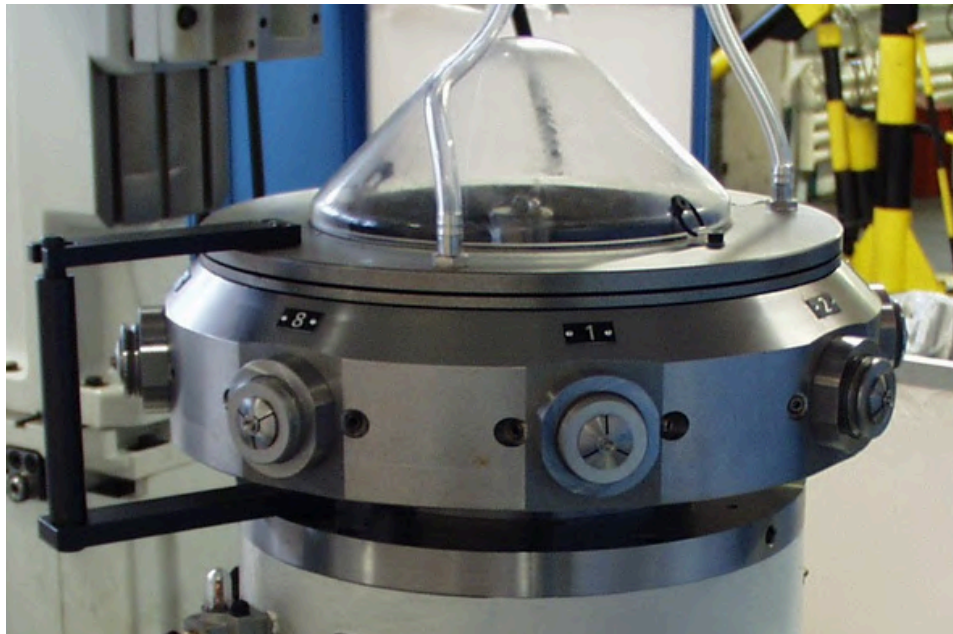

up to
12 Stations

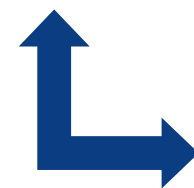

chuck direction
**vertical
& horizontal**

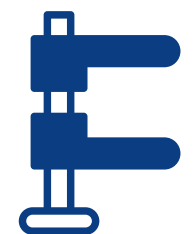

clamping
**external
& internal**

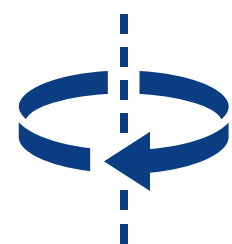

inter-station
**B-axis
positioning**

Thanks to the Cam Indexing Table developed by Technica, workpieces can be rotated and positioned at the desired angle during transitions from station to station. This provides the flexibility our customers need without requiring additional stations or equipment to change the workpiece position.

All operations around the workpiece (360 degrees) can be performed by rotating the workpiece between stations.

When a different operation is needed or the rotation angle must be changed, the desired movement is achieved simply by changing the cam in the indexing table.



SWISS
MADE

3000 SERIES

CNC MODULES

07

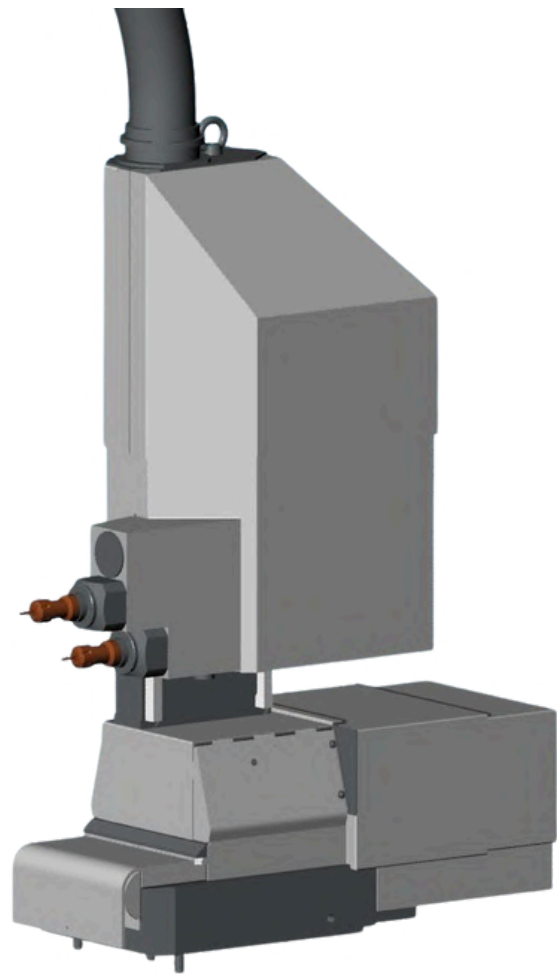

 **horizontal**
double

2 spindles can be placed horizontally on the 3-axis platform

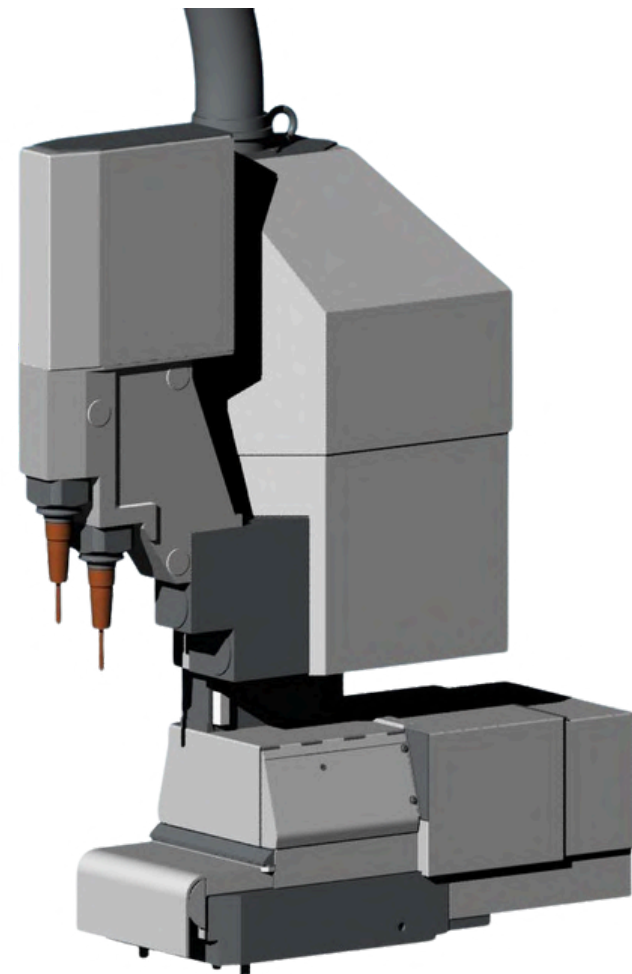

 **vertical**
double

2 spindles can also be placed vertically on the 3-axis platform.

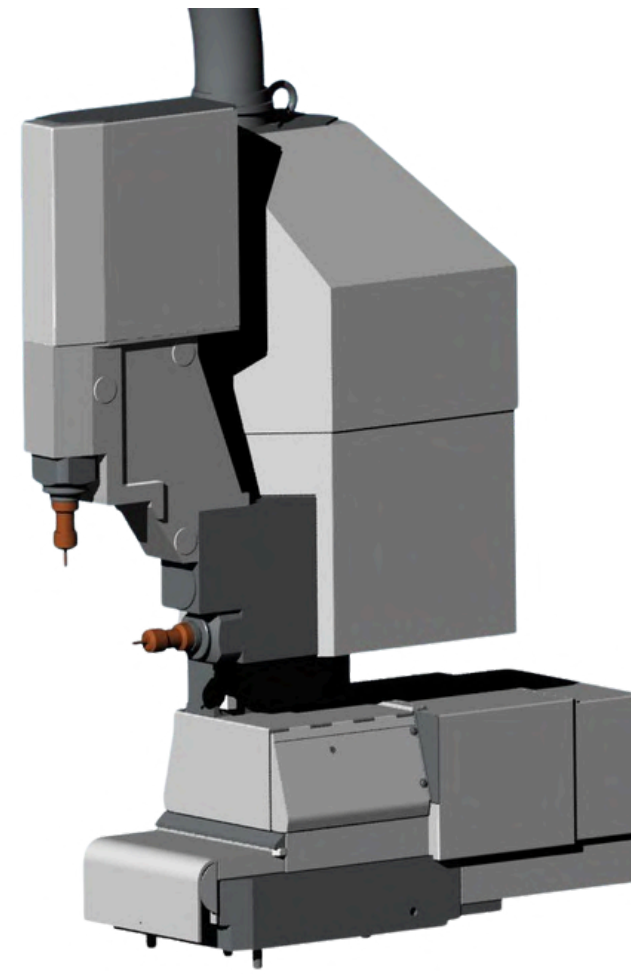

 **horizontal &
vertical**

Spindles can be adjusted; one in a horizontal position and the other in a vertical position.

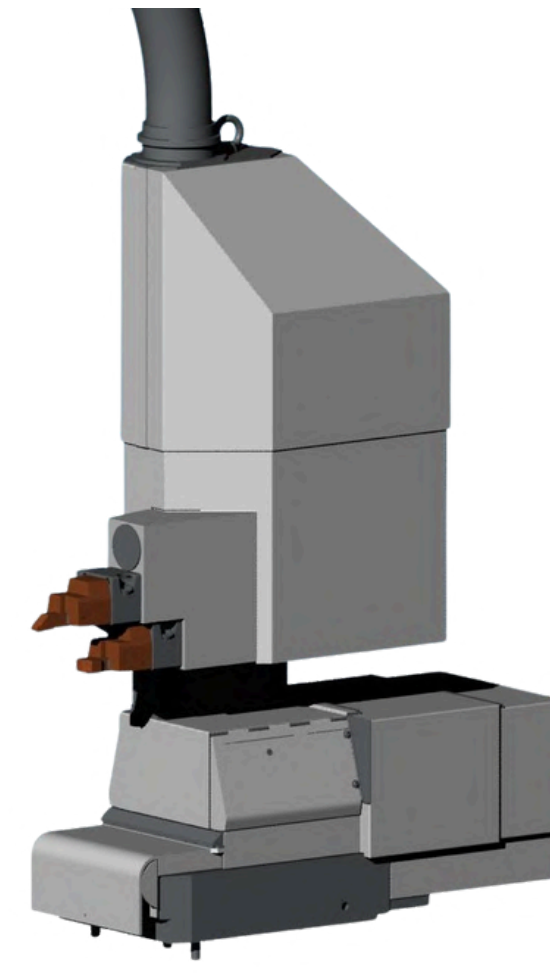

 **turning tools**

Tools for turning instead of spindles can also be mounted on 3-axis platforms.

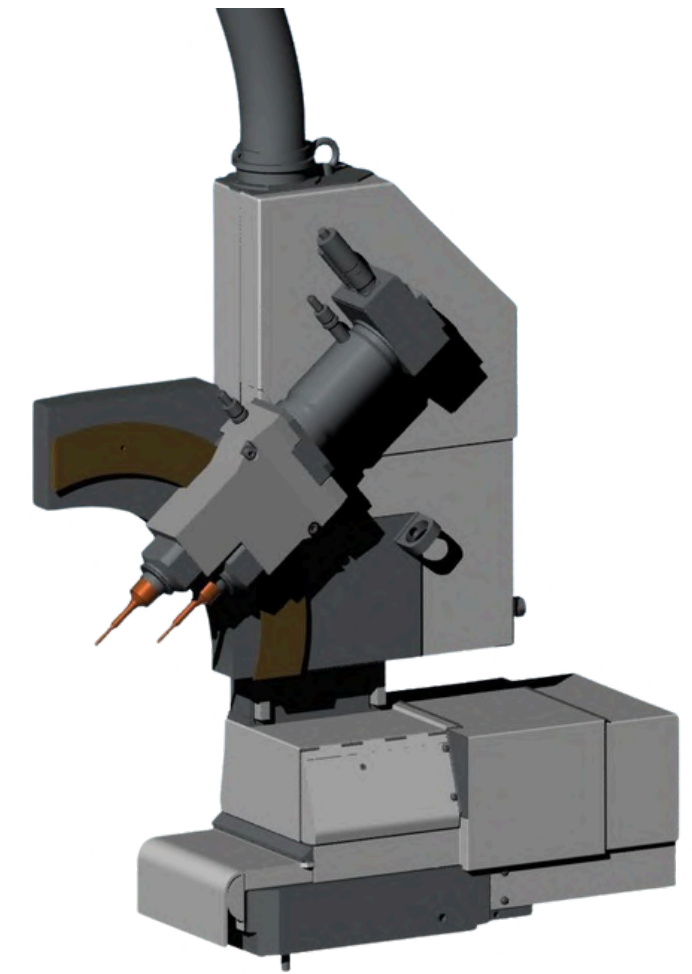

 **angular**
0°-90°

Spindles can also be positioned at angles between 0° and 90° on 3-axis platforms.



3000 SERIES

CNC MODULES

07

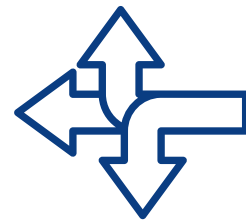
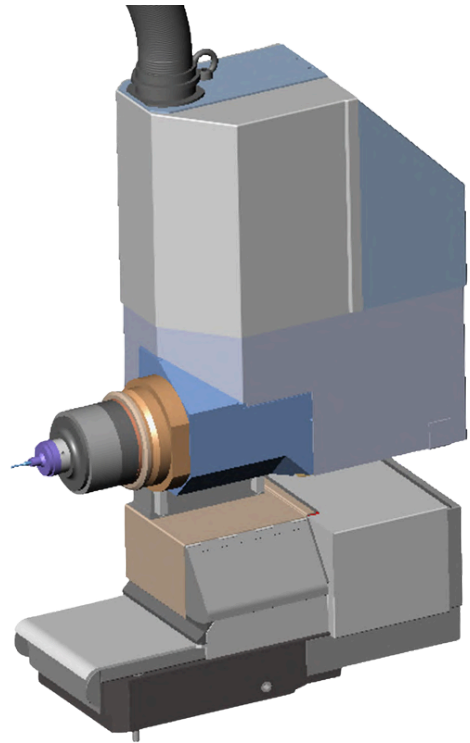

U-axis
recessing
heads

SPECIAL HEADS

U-axis operations are also possible with MAPAL brand recessing heads. Thus, operations such as grooving inside and outside the workpieces, form machining, and single point-thread cutting can be performed with recessing heads as an alternative to our standard applications.

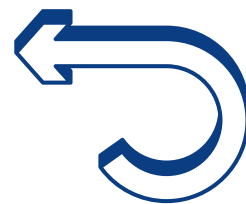
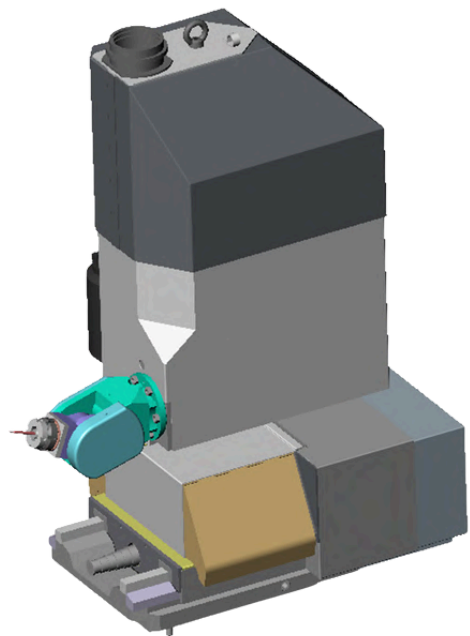
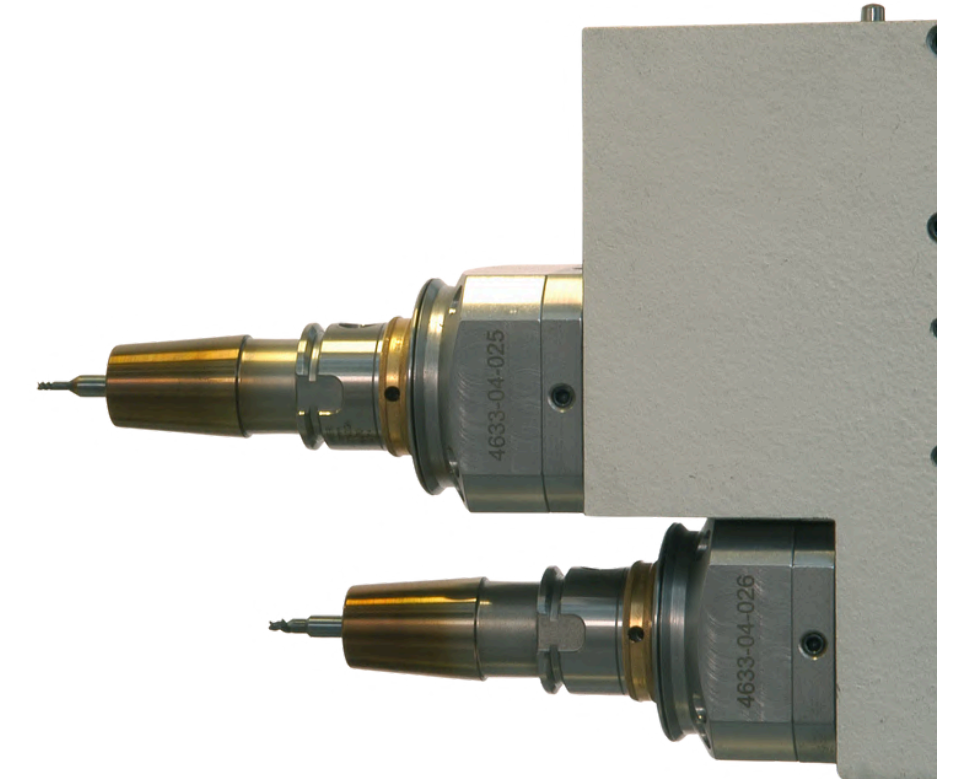

angle
variable
heads

In addition to our modules that can be positioned at fixed angles, 5-axis operations are possible on rotary transfer machines with heads that can make real-time and simultaneous A-axis angle movements.



07

3300 SERIES CNC MODULES

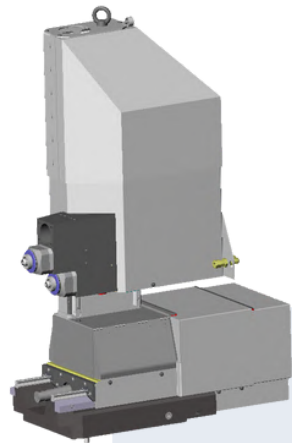

HSK-32

X-axis 60 mm ; Y-axis 120 mm; Z-axis 160 (+10) mm

DW4-1.3-4-ROW

DW4-3-6-ROW

1.1 kWh
max. 2.2 kWh

1.88 kWh
max. 3.9 kWh

8,000 rpm
max. 20,000 rpm

6,000 rpm
max. 7,000 rpm

1.3 Nm
max. 2.6 Nm

3 Nm
max. 5.4 Nm

1,000 N
max. 2,000 N

1,000 N
max. 2,000 N

20 m/min

20 m/min

3400 SERIES CNC MODULES

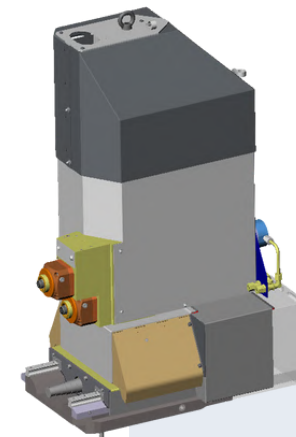

HSK-40

X-axis 100 mm ; Y-axis 140 mm; Z-axis 150 (+10) mm

DW5-6-4-ROW

DW5-15-10-ROW

2.3 kWh
max. 4.7 kWh

4.3 kWh
max. 12 kWh

8,000 rpm
max. 15,000 rpm

4,000 rpm
max. 5,800 rpm

2.7 Nm
max. 9 Nm

8.9 Nm
max. 32 Nm

1,800 N
max. 4,000 N

1,800 N
max. 4,000 N

20 m/min

20 m/min



tool holder



strokes



motor type

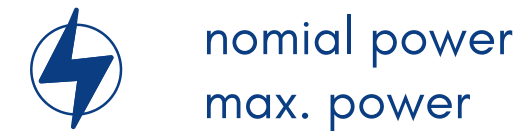

nomial power
max. power

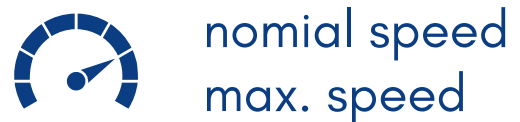

nomial speed
max. speed



nomial torque
max. torque



nomial feed force
max. feed force



rapid traverse



SWISS
MADE

4000 SERIES

MANUAL MODULES

07

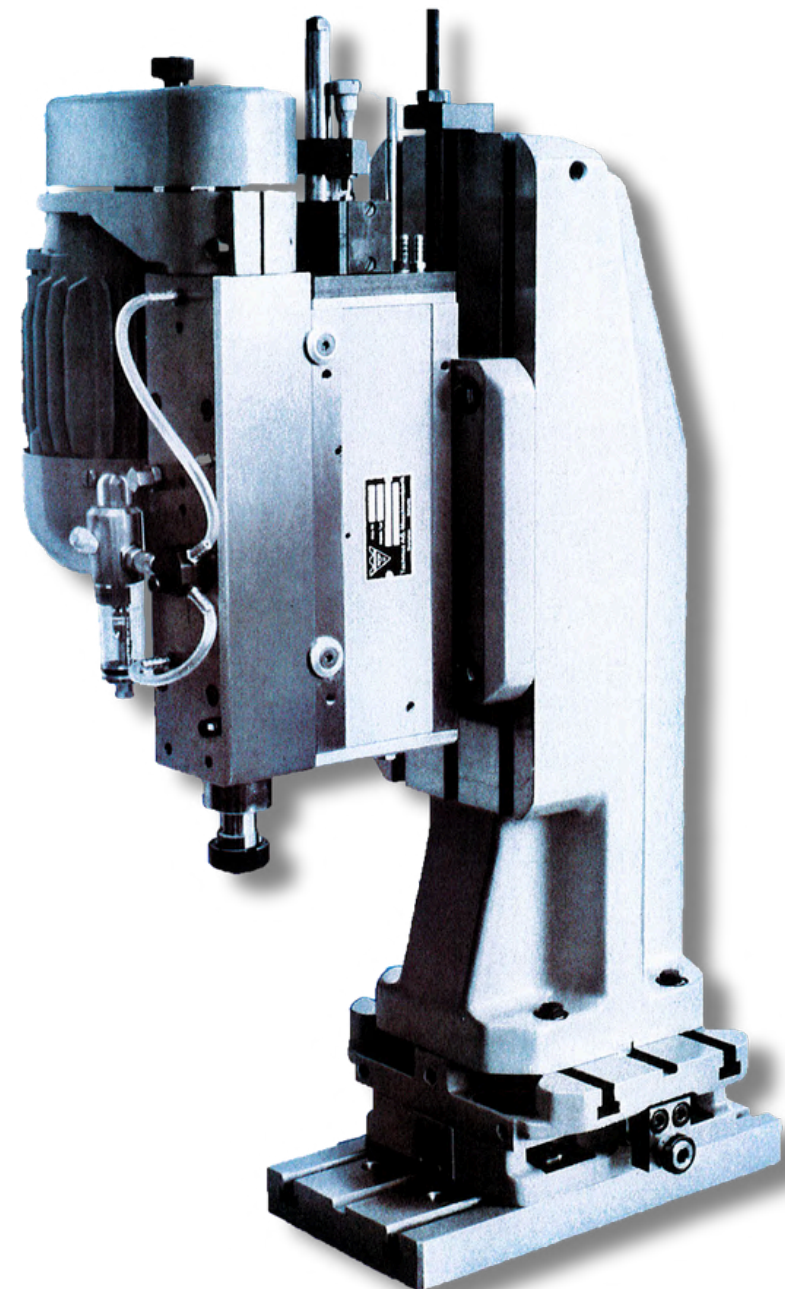
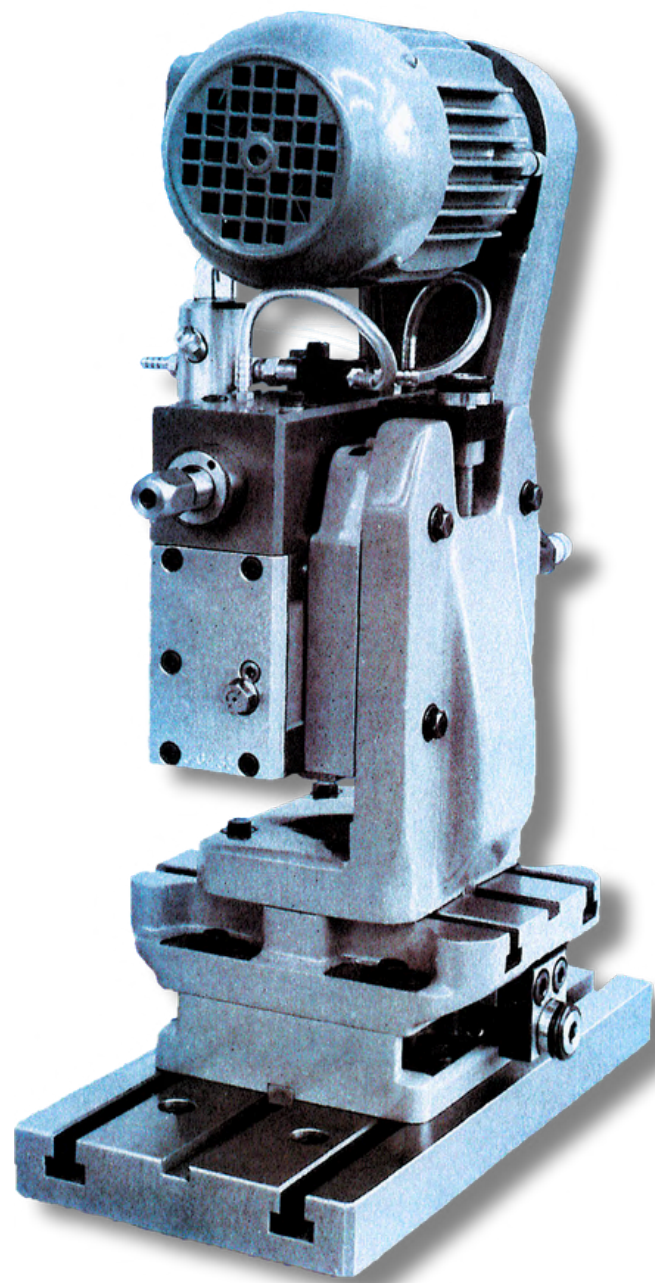

4000 series manual adjustment modules are still available in our stock for use in old Technica modular and rotary transfer machines and can be produced if needed. It is also possible to convert these modules into NC or CNC modules by adding servo motors.

The legendary 4000 series units are still widely used today because of their durability and reliability that have stood the test of time. They offer a comprehensive solution for customers who want to avoid electronic problems, value durability and continuity, and prefer making mechanical adjustments.

08

OPERATIONS

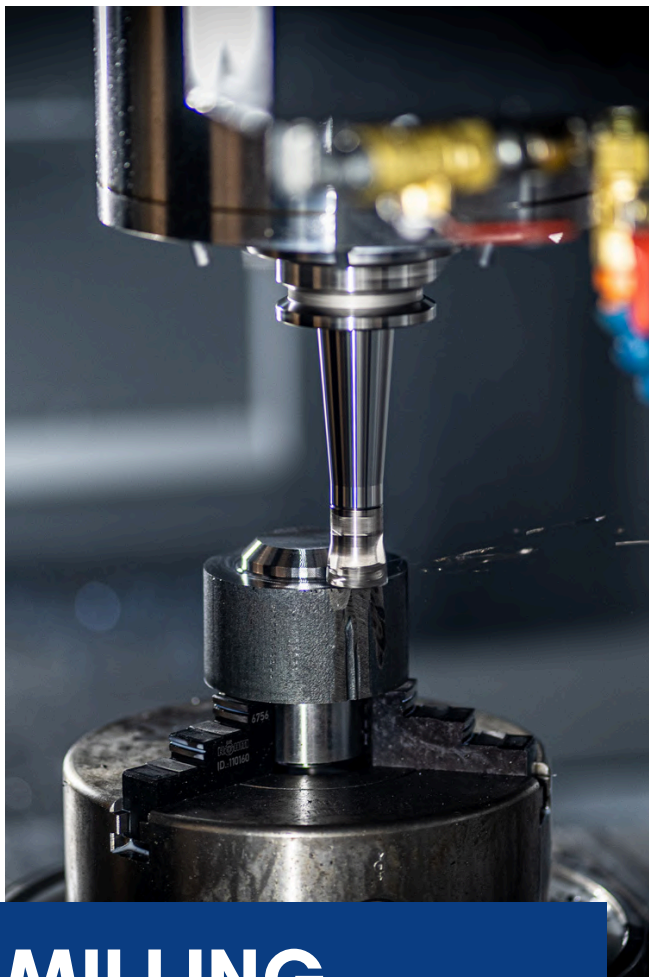
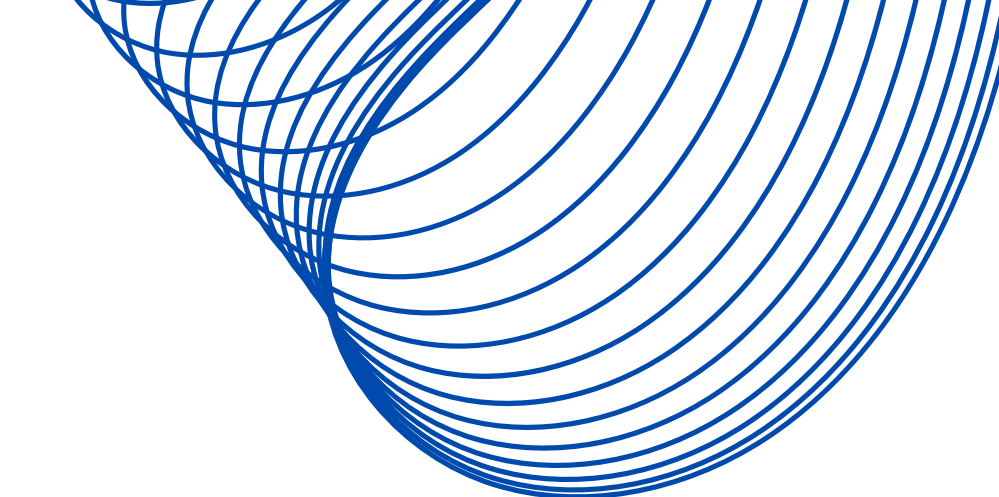

MILLING

1. Face Milling
2. End Milling
3. Slot&Pocket Milling
4. Profile Milling
5. Form Milling
6. Gear Milling

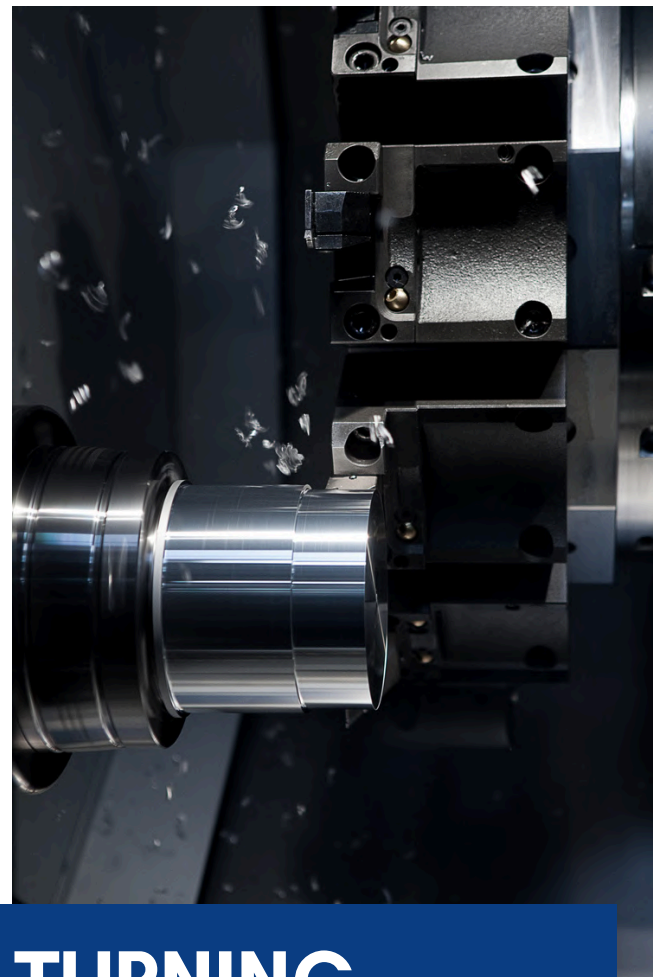

TURNING

1. Straight Turning
2. Taper Turning
3. Profiling
4. Grooving
5. Boring
6. Polishing&Finishing

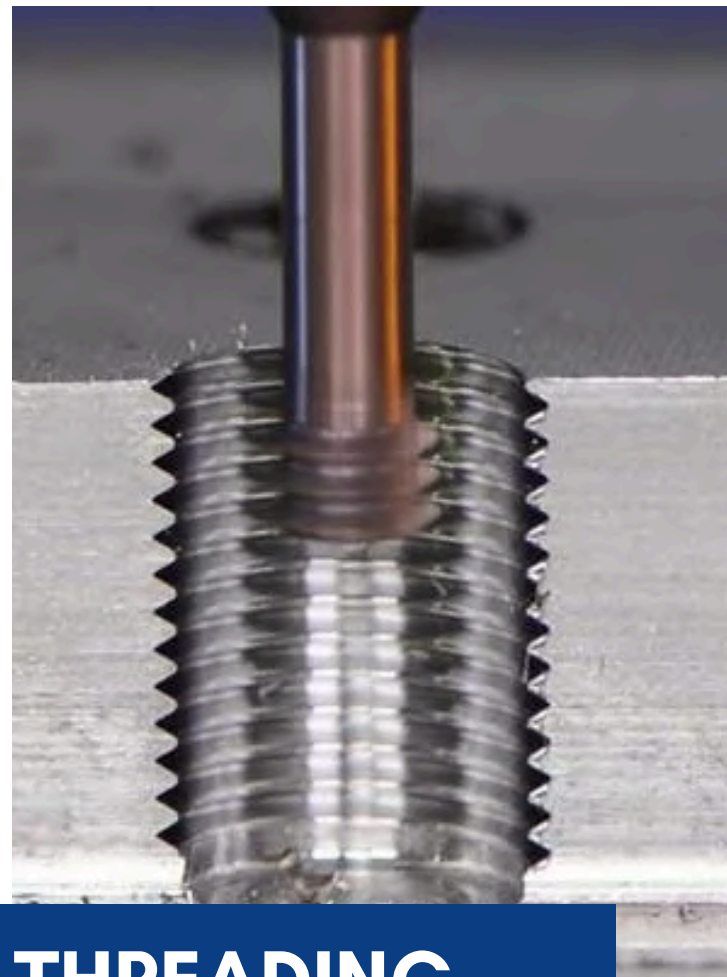

THREADING

1. Tapping
2. Die Threading
3. Thread Milling
4. Single-Point Thread Cutting
5. Thread Rolling
6. Thread Whirling

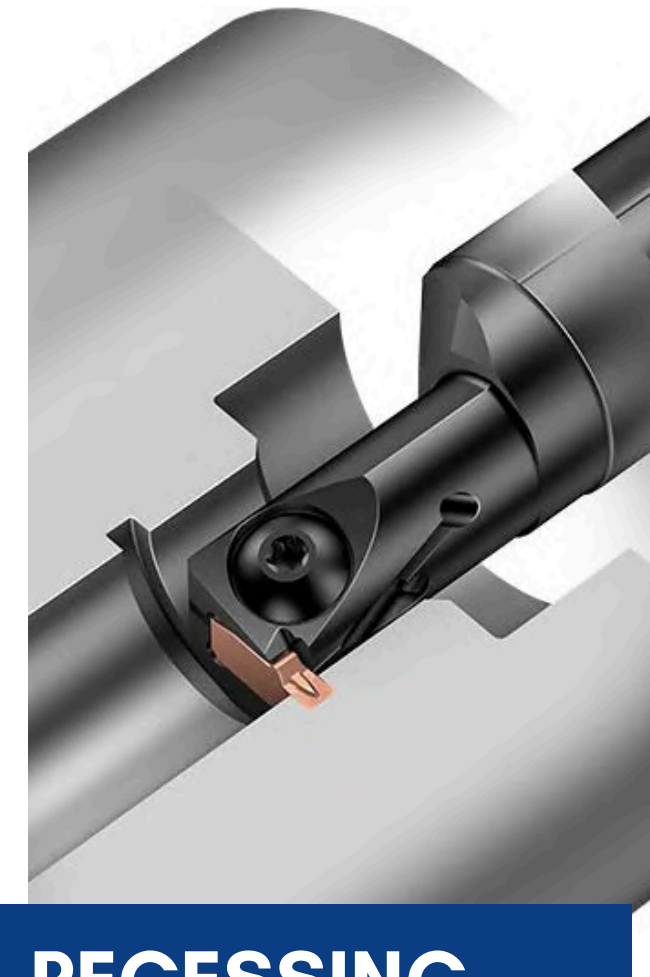

RECESSING

1. Internal&External Grooving
2. Form Machining
3. Finish Machining
4. Face Turning
5. Single-Point Thread Cutting



ANGULAR MACHINING

- 0°-90°
Drilling, Milling, Turning,
Threading, Boring, Reaming
and all other machining
operations

08

OPERATIONS

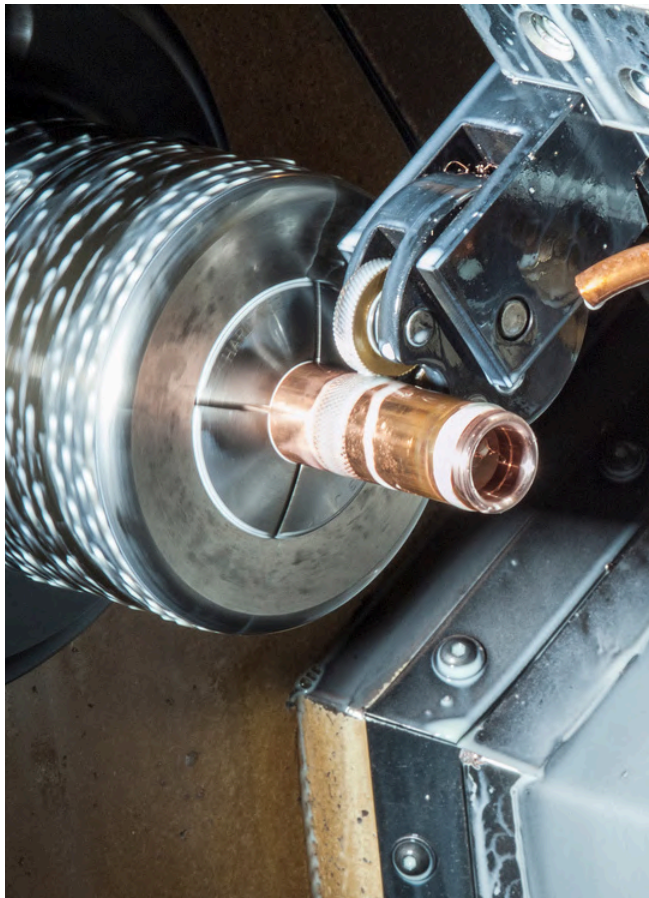
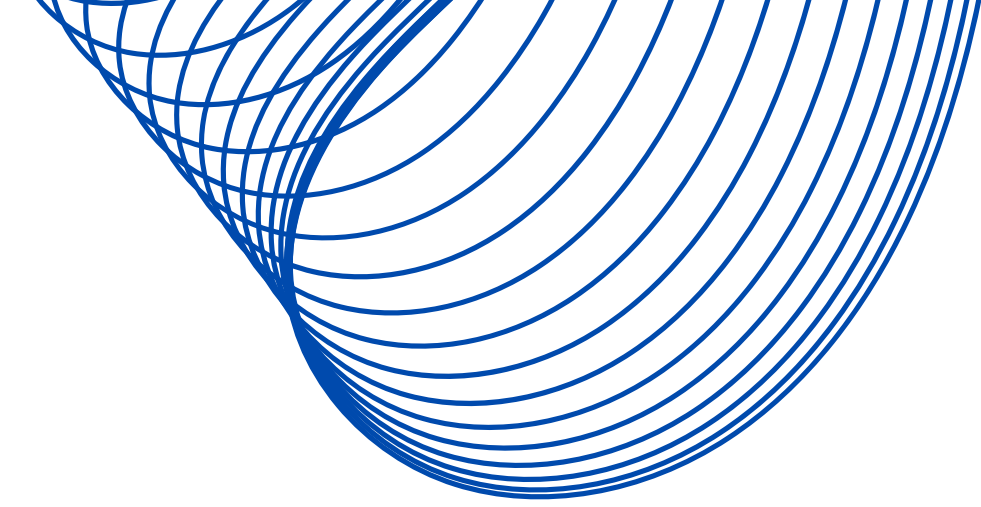

KNURLING

1. Straight Knurling
2. Diamond Knurling
3. Helical Knurling
4. Knurl Rolling



ENGRAVING

1. Surface Engraving
2. Deep Engraving
3. Single-Point Cutter Engraving

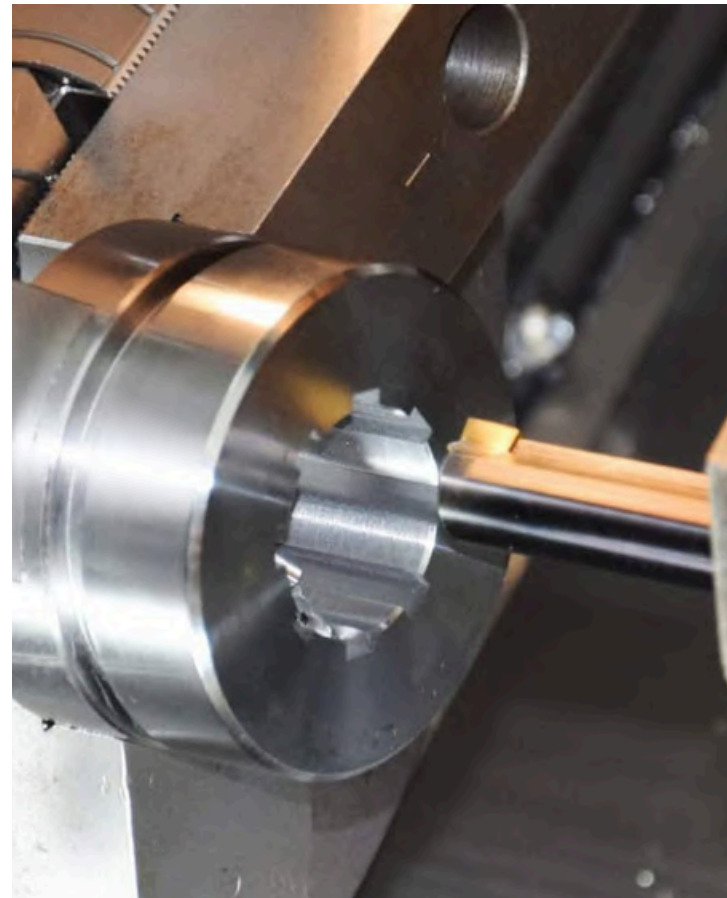

BROACHING

1. Internal Broaching
2. External Broaching
3. Slot&Keyway Broaching
4. Rotary Broaching



SAWING

1. Circular Sawing
2. Band Sawing
3. Slotting



OTHERS

1. Reaming
2. Boring
3. Deburring
4. Conterboring
5. Countersinking
6. Marking

TECHNOLOGIES & TECHNICS

09

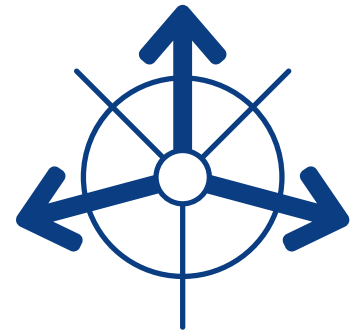

up to **5-Axis Machining**

Each standard module in the 3000 series can move along the X, Y, and Z axes. Additionally, thanks to the TWS Pallet System developed by Technica, workpieces can be rotated simultaneously to any desired angle on the B-Axis.

Furthermore, with the 0-90° fixed angle adjustment units or angle-changeable heads, operations can be performed on the A-Axis in addition to the X, Y, Z, and B axes. The angles of the fixed adjustment units can be changed mechanically at any time, while the angles of the angle-changeable heads are adjusted electronically without mechanical intervention.

Thanks to Technica's flexibility, 5-axis simultaneous operations on a transfer machine are definitely achievable.

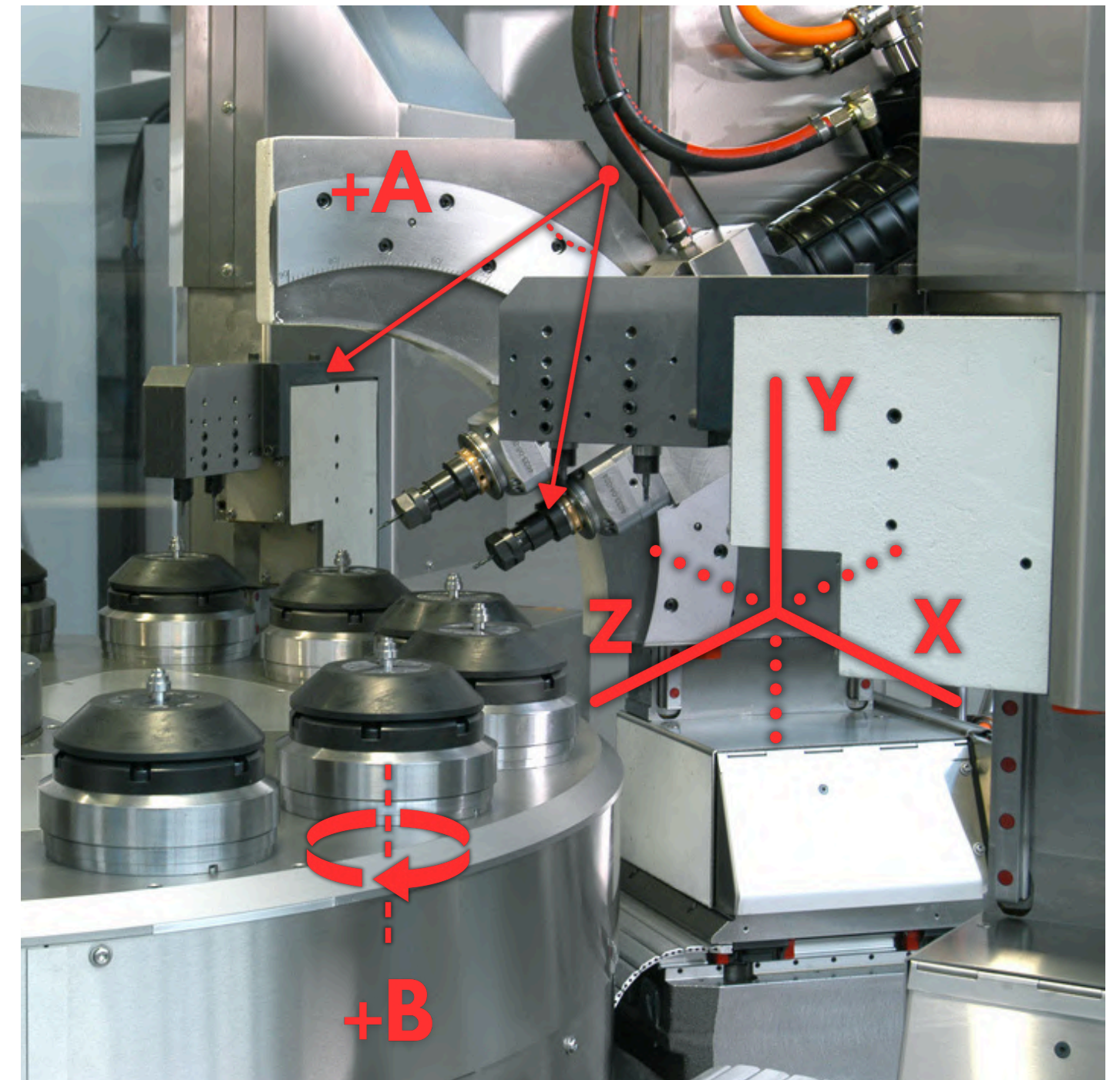

TECHNOLOGIES & TECHNIQS

09

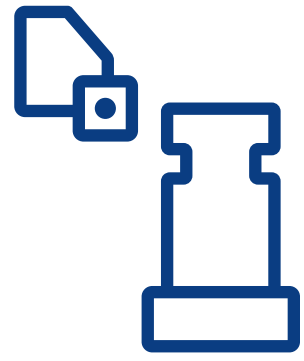

up to
6,500 rpm Turning

Thanks to the Technica TWS Pallet System, workpieces can be rotated not only on the B axis but also turned at speeds up to 6,500 rpm. By connecting turning tools to the 3-axis moving modules, real turning operations can be performed on Rotaflex CNC rotary transfer machines.

In addition, spindles other than turning tools can be used in both horizontal and vertical alignment. This allows both turning and milling operations within a single station.

Moreover, all these operations can be performed at any desired angle using angled modules. With Technica technologies, there are no limits to flexibility and options.

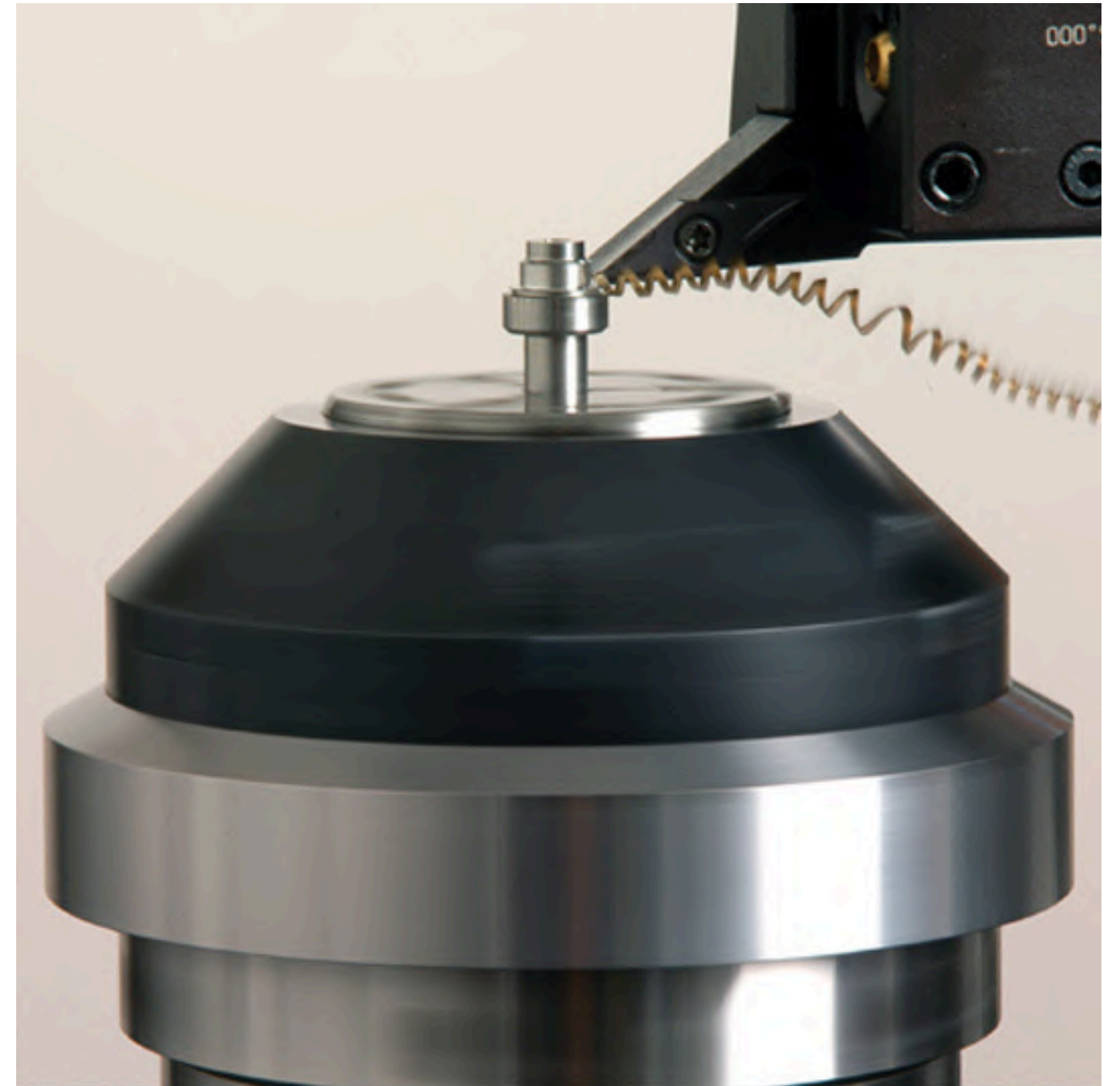

TECHNOLOGIES & TECHNICS

09



Plug&Run Chucks

Technica's Plug & Run Chuck system revolutionizes part-to-part transitions by enabling **the quick replacement of chucks in less than one minute**. Chucks can be easily attached and detached without any mechanical adjustments or the need to tighten bolts.



PLUG&RUN
CHUCKS



HSK C SERIES
TOOL HOLDERS



HSK C Series Tool Holders

HSK C Series Tool Holders, offered as an alternative to the Pull-Stud system, enable our customers to switch from one part to another quickly and cost-effectively. **Each tool change takes less than one minute** and requires only the loosening and tightening of a single bolt.

TECHNOLOGIES & TECHNICS



Tool Monitoring

Nordmann brand tool monitoring systems monitor cutting tools in real time. They report not only tool breakage but also tool dulling. The tool monitoring system ensures consistent performance and quality.

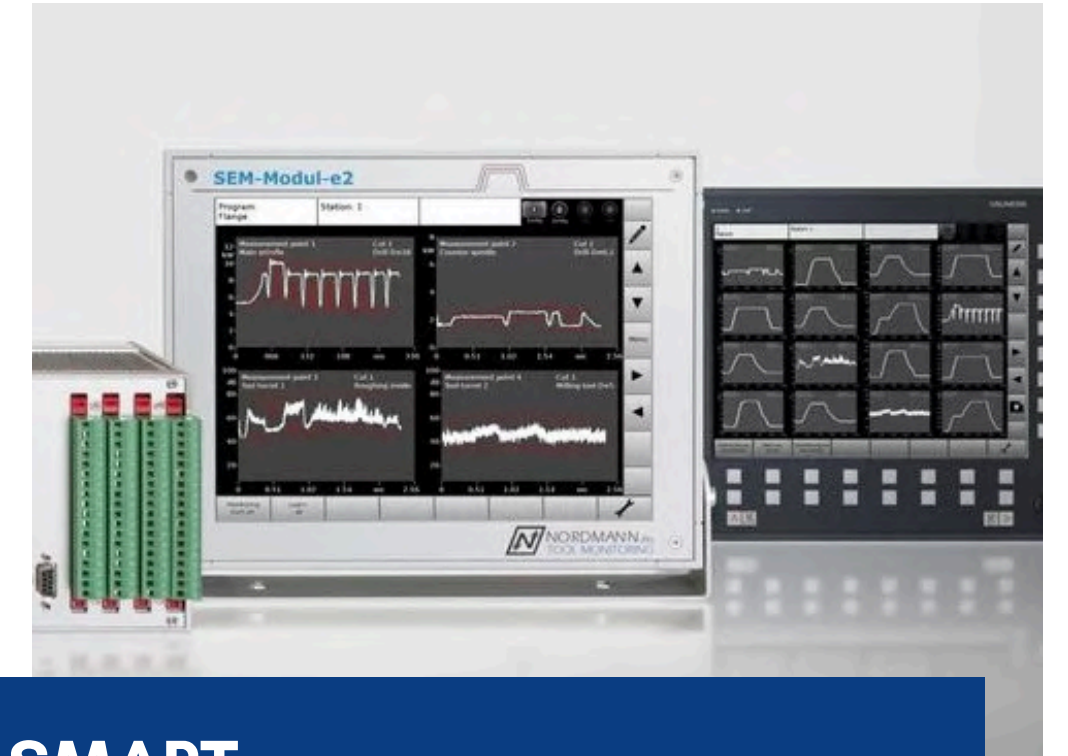

**SMART
MONITORING**

09



**6-AXIS
ROBOTIC ARM**

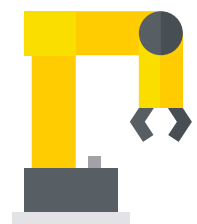

Robotic Automation

Loading and unloading operations are completed automatically and quickly with integrated Stäubli brand 6-axis precision robot arms. For high-capacity jobs, the double robot arm option completes loading and unloading in seconds.

TECHNOLOGIES & TECHNIQS

09



In-Machine Measuring

We offer laser or touch sensors to measure workpieces or tools. By performing measurements before machining, we ensure process safety. After machining, we measure the conformity of the workpieces and sort them accordingly.



SENSOR
INTEGRATION



MODULAR
SYSTEM

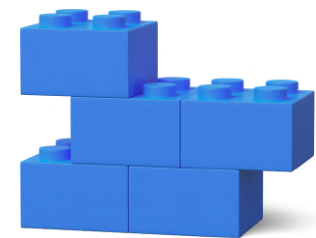

Modular System

Technica rotary transfer machines stand out for their flexibility. Their modular structure, similar to LEGO blocks, allows complete reconfiguration of the machine. **Replacing each module takes only 2 to 3 hours.**

10

ACCESSORIES

To enhance the benefits and efficiency of Rotaflex CNC transfer machines, we offer a wide range of accessories for various applications. These include **automation solutions for machine feeding, chip conveyors, coolant filters, coolant chillers, oil-mist filters, and fire suppression systems.**

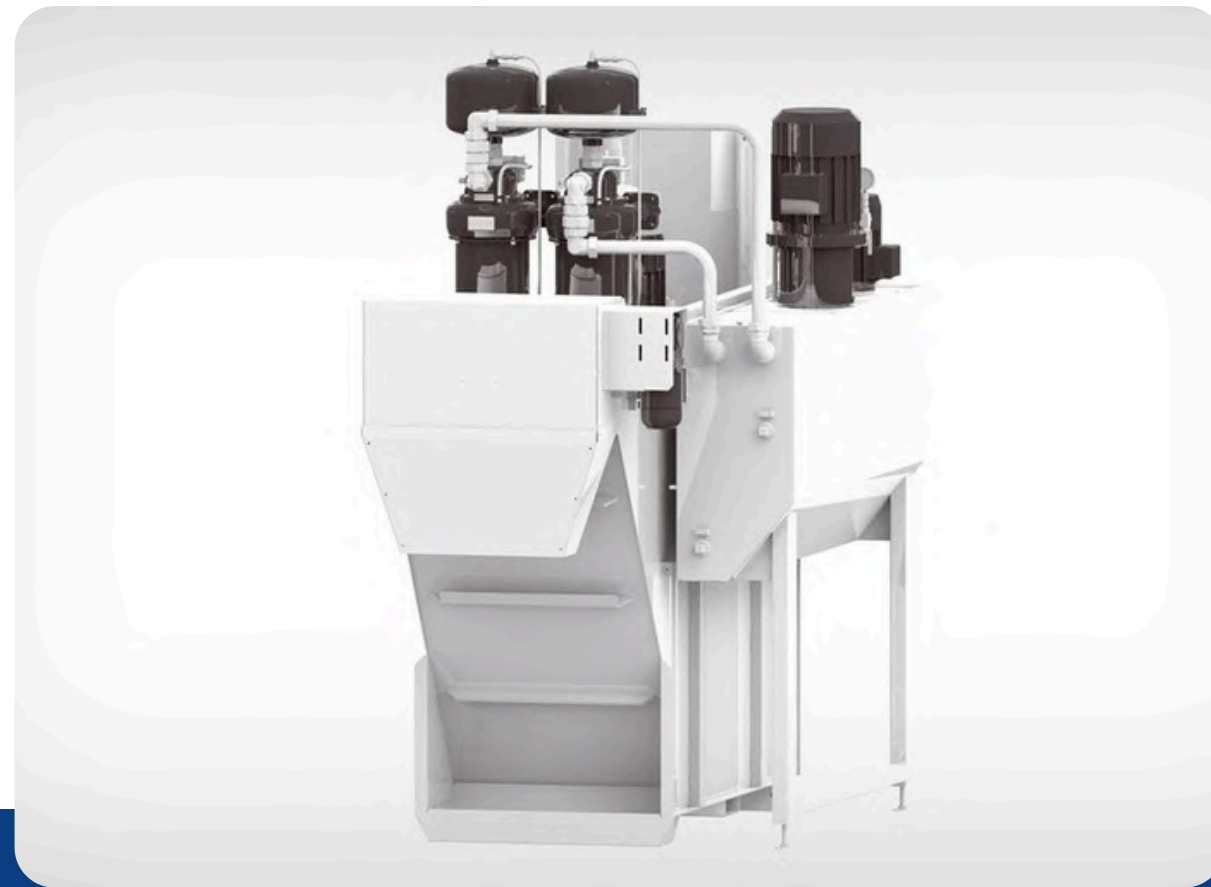

chip conveyor, coolant filter, coolant chiller

REFURBISHING & REMASTERING

11

Thanks to high-quality equipment, advanced Swiss engineering, and meticulous workmanship, our machines have been running with some customers for over 50 years.

However, with technological advances, some customers now require CNC modules and CNC control panels. For these customers, we offer **the Remastering option**, which upgrades their old machine with a new BWO control panel and Beckhoff control system to meet modern requirements.

For customers who do not need a technology upgrade but want to extend their machine's lifespan through essential revisions, we offer **the Refurbishing option**.

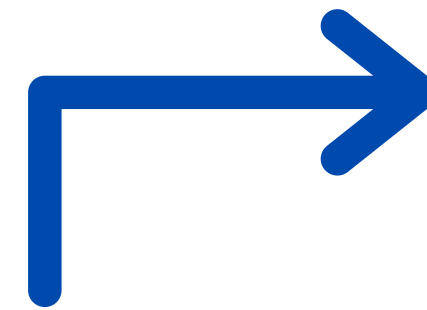

bwo

BECKHOFF



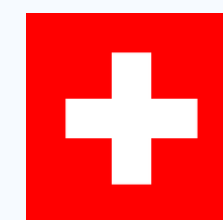
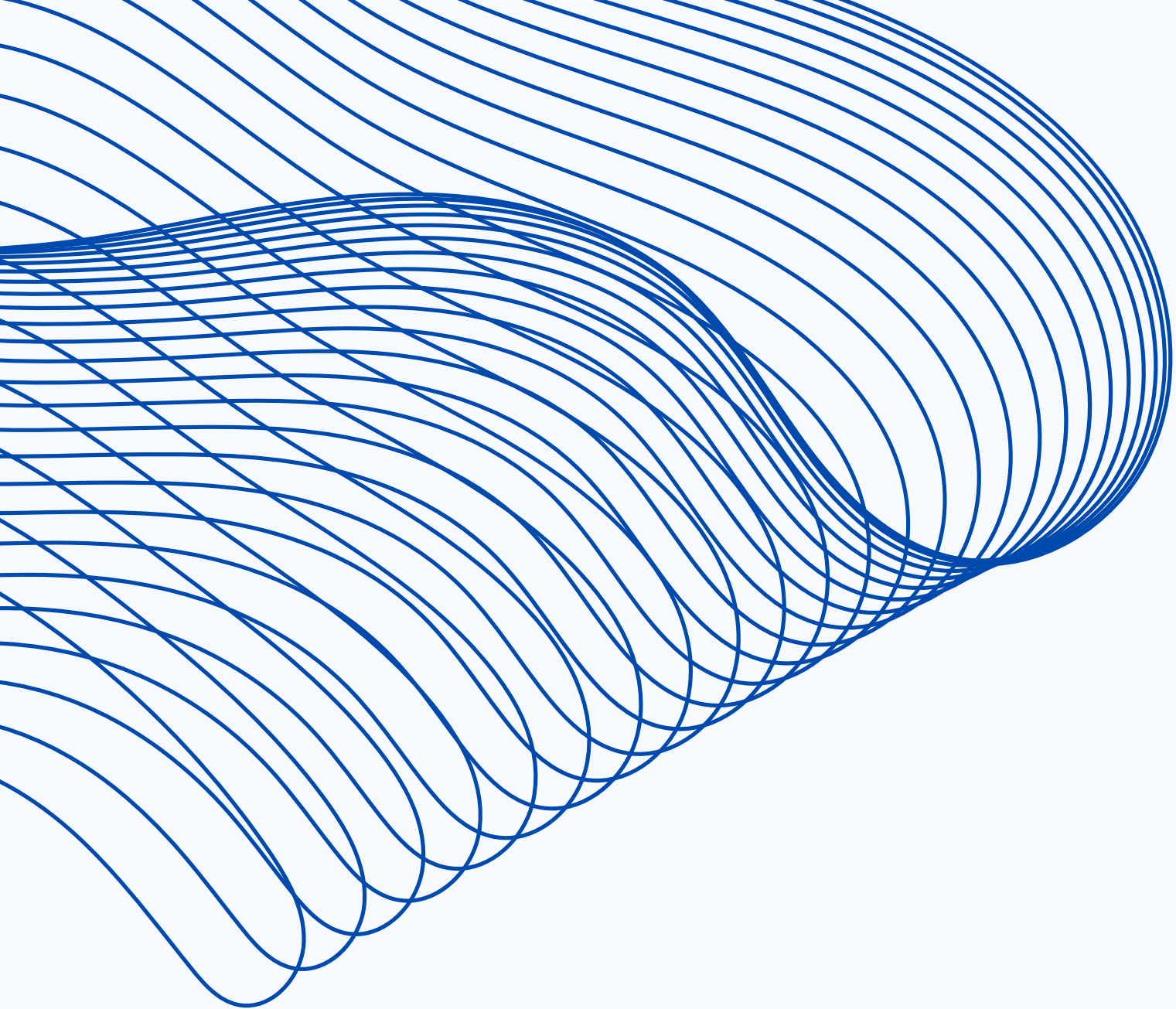

technica
technology gmbh

CONTACT

www.technica.ch

info@ws-technica.com

+41 32 654 80 60

Gewerbestrasse 10 4552 Derendingen, Switzerland

KENAN KIZIL

SALES MANAGER

kenan.kizil@ws-technica.com

+41 77 957 16 12

BERTHOLD MAIER

SALES MANAGER

berthold.maier@ws-technica.com

+49 172 269 48 92