



Translation of
**ORIGINAL
OPERATING INSTRUCTIONS**

For Ruma Cleaning Centrifuge MZ35

For Ruma Cleaning Unit MZ35 AS

Machine No.: 2036.448.00

Dated: 2023



Index

1.	For your Safety	3
2.	Capabilities of the Centrifuge	4
3.	Technical Data	4
3.1	Data of Centrifuge	4
3.2	Data of Unit	5
3.3	Type Label	5
4.	Transport, Installation and Initial Operation	5
4.1	Placing the Centrifuge	5
4.2	Preparation to Launch the Unit	6
5.	Components and Mode of Operation	7
5.1	Components	7
5.2	Construction	7
5.3	Mode of Operation	8
5.4	Cover of Rotor	8
5.5	Discharge of Solid Insert	9
6.	Control	9
6.1	Control Device	9
6.2	Description	10
6.3	Additional Functions	10
7.	Container and system pumps	11
7.1	Adjustment of the Pumps / Level of Purity	11
7.2	Level Monitoring (optional)	12
7.3	Suction Unit (optional)	13
8.	Faults	13
8.1	Possible Causes of Faults	13
9.	Operating the Unit	15
10.	Service	15
11.	Maintenance of the Centrifuge	16
11.1	Dismounting of the Rotor	17
11.2	Dismounting of the Drive Belt	17
11.2	Level Monitor	
11.4	Dismounting of the Outlet Pipe	17
12.	Disposal	18

Appendix

Declaration of Conformity

Diagram (Table of Dimensions) Centrifuge MZ35

Drawing M 1012.70

Diagram (Table of Dimensions) Unit MZ35 AS

Drawing M 1012.60

Level Sensor

Drawing S 0000.00

Drawing of Spare Parts Centrifuge MZ35

Drawing E 1019.68

List of Spare Parts Centrifuge MZ35

List of Wearing Parts MZ MZ35

Drawing of Spare Parts Unit MZ35 AS

Drawing E 1019.55

List of Spare Parts Unit MZ MZ35 AS

Wiring Diagram

5035.516.83

1. For your Safety



This unit has been built according to the latest technical standards and acknowledged safety-related rules. Nevertheless, its use may constitute a risk to life and physical condition of the user or third parties, or may cause damage to the machine or other materials. **Operating instructions must always be kept next to the unit.**

For the centrifuge the DGVU principle 313-001 applies.

Before you start the centrifuge, make sure that the housing cover is firmly closed (cover lock). The housing cover can only be opened after the centrifuge rotor is standing still. The cover lock also operates in voltage-free condition.

WARNING



Electric shock because of damage at power cable.

- Only use centrifuge in professional installed and repaired condition.
- In case of danger detach centrifuge from main voltage, e.g. switch off power supply (unplug).

WARNING



Electric shock because of wrong power supply

- .Connect centrifuge only to sources that match with electrical requirements on the type label
- Only use connection cables with sufficient fuse and corresponding lines. Note VDE 0100.
- PE ground conductor can have a high leakage current.

WARNING



Finger bruises through opening and closing the housing cover

- When opening the housing cover do not grab between cover and housing.
- Always open housing cover fully and secure against falling down.

WARNING



Injuries because of improper attached rotor covers and housing covers

- Only run the centrifuge with firmly closed rotor cover and housing cover.

WARNING



Injuries because of falling loads

- Never stand or work underneath suspended loads.

WARNING



Massive hand injuries through running rotor

- Never put a hand into a spinning rotor.
- During operation keep centrifuge and rotor cover firmly locked.

WARNING



Massive hand injuries through rotating parts

- Secure bottom of the centrifuge against contact.
-

Only do welding and grinding work at this unit when it is explicitly allowed, there may be a **fire and explosion hazard**.

Please make sure, that the unit and the surroundings are free of dusts and flammable substances and there is enough ventilation before welding and grinding (explosion hazard).

2. Capabilities of the Centrifuge

It is only allowed to use liquids with no risk of burning and explosion and generally only liquids after DIN 6601 in this unit (DIN 6601: Resistance of materials of steel containers against liquids), such as

- » Emulsions
- » Oils
- » Electrolyte
- » Waters from slide grinding
- » Liquids with a pH-Value between 5,5 and 9,5

The specific density of the solids that are supposed to be separated must be heavier than the liquids.

3. Technical Data

3.1 Data of Centrifuge

Separation of solid materials depend on the flow rate (duration of liquids in the rotor), viscosity of the liquids, specific density, shape and size of the solid particles and separating factor of the centrifuge.

The following data on volume flow rates in relation to the viscosity only give standard values:

Volume Flow:		
Viscosity	1 cSt (1°E)	35 l/min
Viscosity	21 cSt (3°E)	20 l/min
Viscosity	60 cSt (8°E)	10 l/min
Driving Power:		0,75 kW
Operating Voltage:		400V 50Hz
Temperature of the Medium Min./Max:		10 - 50 °C
Temperature of the Environment Min./Max:		10 - 50 °C
Speed of Rotor:		4615 min ⁻¹
Separating Factor:		2000 g
Capacity of Rotor:		3,0 dm ³
Capacity of Insert of Solids:		1,5 dm ³
Inlet Connection:		3/4 "
Inlet Height:		spezific
Drain:		with counter-pressure 0,3 bar
Dimensions:		see diagrams
Net Weight:		42 kg (centrifuge)
Equivalent permanent noise pressure level at 1 m distance and 1,6 m height:		< 70 dB(A)

3.2 Data of Unit

Operating Voltage:	400V 50Hz
Control Voltage:	24V DC
Supplying pump	Q= 30 l/min p= 0,8-1,5 bar
Capacity of Container:	B
Weight of Unit:	300 kg
Dimensions:	see diagrams

3.3 Type Label

Machine Type	MZ35 AS	Flow rate min/max	10 - 35 l/min
Machine No.	2036.448.00	Max. Feststoffmenge	6 kg
Year of Construction	2023	Wiring Diagram No.	5035.516.83
Rotating Speed	4615 U/min	Rated Power	2 kW
Rotor Ø	230 cm	Operating Current	7 A
Max. Rotating Speed	4615 U/min	Voltage	400V 50Hz
Medium Temp. min/max	10 - 50 °C	Voltage of Steering	24V
Weight of Unit	300 kg	Safety Fuse	16 A, indolent

Subject to technical alterations!

4. Transport, Installation and Initial Operation

PLEASE NOTE:

Secure unit sufficiently

Usually the unit is delivered on a wooden pallet. It can be moved easily by a fork-lifter to its operational place.

4.1 Placing the Centrifuge

- » At an easily accessible place.
- » On a solid and even underground (uneven setting-up grounds can cause turbulent run/vibrations).
- » Acceptable environment temperature has to be between +10°C and +40°C.
- » Outside explosive areas.
- » Don't run in wet rooms or outdoors.
- » Protect bottom side with relevant safety devices against contact.

WARNING



Severe injuries on hands through rotating parts

- Secure bottom of centrifuge against contact.

Work on / with the system must be carried out by trained and instructed staff. Note the legally permissible minimum age! Establish responsibilities of personnel for operation, setup, maintenance and repair course.

Any handling with the electric equipment of the units must be carried out only by an electrician.

Electric supply lines: The required supply lines for electricity (according to the attached electrical diagram) including fuses, as well as compressed air and if necessary fresh water to run this unit will be installed by the operator sufficiently in compliance with the applicable regulations.

PLEASE NOTE:

Note water protection act.

All direct inlet and outlet lines to and from the centrifuge must be made out of flexible pipe connections that will avoid that any vibrations of the centrifuge are being transmitted to the unit and the pipes.

On the attached diagram it is shown the position of the inlet of the contaminated liquids and the outlet of the cleaned liquids out of the centrifuge. Because of the low height of the unit, the contaminated liquids can be supplied to the centrifuge in direct free-fall.

WARNING**Electric shock through wrong power supply**

- Connect centrifuge only on sources that match with electrical requirements on the inscription plate.
 - Only use connection cables with sufficient fuse and corresponding lines. Note VDE 0100
 - PE ground conductor can have a high leakage current.
-

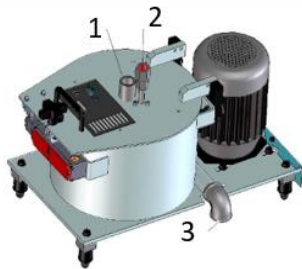
4.2 Preparation to Launch the Unit

- » Place the centrifuge and screw tight.
- » Attach flexible pipe (1) from the inlet to the production machine with a regulation, e. g. through a ball valve and secure with pipe bracket.

Don't exceed maximum flow rate.

Centrifuge	Maximum Flow Rate
MZ35	Q= 35 l/min for emulsions
MZ35	Q= 20 l/min for oils

PLEASE NOTE:

Exceeding maximum flow rate can cause bearing damage.

- » Make flexible hose connection from peeling pipe (3) to clean tank and secure with pipe clamps. Do not reduce or block the connection. We recommend choosing a "connection. Depending on the required flow rate of the medium and the formation of foam, the hose can also be reduced or expanded. We will be happy to help you choose the correct hoses.
- » not immerse leakage pipe (2) without a vent hole in the medium in the container, to prevent back-suction of the liquid into the centrifuge. The leakage fluid of the centrifuge must be able to flow freely into an existing container.

PLEASE NOTE:

An overflowed container causes disruptions and possibly, a bearing damage.

- » Connect electrical equipment.

PLEASE NOTE:

Electrical connections must be made by an electrician.

- » Connect centrifuge motor. The rotor of the centrifuge must turn clockwise (when looking from above onto the housing cover). The unit is installed in the right rotary field. Prior to connecting the centrifuge please check the rotary field by means of a rotary field testing instrument. Connect safety switch (Euchner).

PLEASE NOTE:

The safety switch must prevent the possibility of opening during operation.

- » Lock rotor cover.
- » Close the housing cover with mounted bolts/clamping bracket by hand.
- » Additionally, the safety switch keeps the housing cover closed.
- » It is **forbidden** to run the centrifuge with an open cover or without a safety switch.

WARNING



Injuries through improper attached rotor covers and housing covers

- Only run the centrifuge with firmly closed rotor cover and housing cover

PLEASE NOTE:

To prevent over-heating or incidents of the control system switch the centrifuge „ON“ / „OFF“ with a maximum of 4 consecutive times.

5. Components and Mode of Operation

5.1 Components

The centrifuge is driven directly or through a Poly-V-belt by the main motor. Inlet of the contaminated medium is through the inlet pipe into the housing cover. Outlet of the cleaned liquids is from the housing. The outlet of the residual liquids is through the drain pipe into the container while the centrifuge rotor is standing still.

Outlet Pipe

The outlet pipe swivels into the centrifuge rotor when closing the housing cover and during separation dips into the rotating ring of liquid. The rotating liquid produces an impact pressure, which allows the cleaned liquid to be diverted on a higher level.

Lid Catch / Cover Lock of the Centrifuge

The cover can be opened only when rotor is at standstill. The cover can be opened by pushing the button (6) „cover open“ by hand. When pushing this button the cover lid is unlocked for approx. 10 seconds. During this time the cover can be opened. The green light (LED) flashes while the security switch is unlocked. With the cover open the current is disconnected, the centrifuge cannot be started.

Control of Stoppage

The standstill of the rotor is controlled by a sensor and is connected with the safety switch (Euchner). The safety switch prevents an opening of the housing cover during the time the centrifuge rotor is running.

Vibration Monitoring (optional)

The vibration sensor is monitoring the vibrations within the centrifuge. If the respective set limit value of the vibration speed and the time are exceeded a fault message ("vibration") signal is issued and the centrifuge is switched off. Causes of vibrations, see Chapter 8 (Vibrations). After removing the cause, the error message on the control board is acknowledged.

5.2 Construction

The rotor of the centrifuge is built into an housing. The housing is connected to the undercarriage with rubber buffers (vibration dampers). The rotor is placed on the main shaft, which has a double bearing in the housing. A protecting switch controls the driving motor against overloading. The entire centrifuge is mounted on a chassis or directly onto a container.

PLEASE NOTE:

The pedestal of the centrifuge also serves as a shock protection of the oar under the floor slab. If only a loosely centrifuge is obtained (without pedestal or container) there be a shock protection appropriated by the customer.

The contaminated liquids are led into the centrifuge through the inlet pipe in the housing cover. The inlet pipe needs to be flexible and be longer than is absolutely necessary so it is able to move easily when the housing cover is being opened.

The leakage liquids of the centrifuge must be able to flow in free-fall into an existing container. It is important, that the pipe does not plunge into the liquids or the foam. Otherwise it is possible, that the liquids or the foam are sucked back. This may lead to disruptions. Where necessary attach a vent.

5.3 Mode of Operation

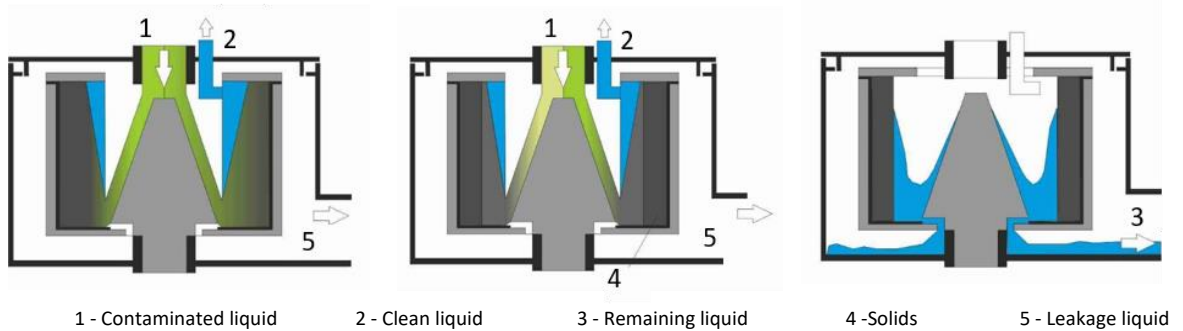

The centrifuge separates solids from liquids using centrifugal forces.

The contaminated liquids are cared centrally through the rotor cover into the rotor and thus fall onto the bottom of the solids insert inside the bowl. By centrifugal forces the liquids are spinned off centre outwards and rises towards the top of the inner wall of the bowl.

On their way to the top the heavy solids are forced to the periphery and settle on the wall of the bowl insert. The cleaned liquids flow through the outlet pipe into a container. When the insert is full, it is removed and replace by an empty/cleaned one which is ready for use.

PLEASE NOTE:

The grade of cleaning is improved by reducing the flow rate.

5.4 Cover of Rotor

PLEASE NOTE:

Solids must be accurately removed from the insert. The sealing surface on the insert and cover must be cleaned. Please make sure that the insert and the cover are fitted properly and the locking bolts are completely locked.
1 - shutter 'open'
2 - shutter 'closed'

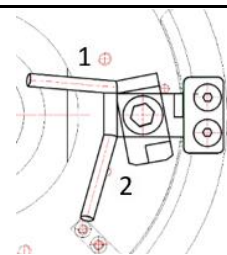

WARNING



Injuries through not proper attached rotor covers and housing covers

- Only run the centrifuge with firmly closed rotor cover and housing cover.

5.5 Discharge of Solid Insert

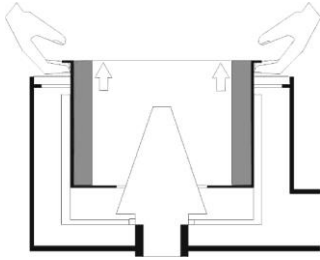

- » Switch off the inlet of liquids.
- » Switch off the centrifuge.
- » Wait until the centrifuge isn't running anymore.
- » Unlock safety switch of the housing cover.
- » Open the mounted bolts/bracket on the housing cover.
- » Unlock the rotor cover by opening the locking bolts/screws .
- » Remove rotor cover.
- » Remove the insert of solids.
- » Remove solids from the insert using a soft scraper.
- » Clean seals.
- » Insert cleaned insert of solids.
- » Check o-ring on the bottom side of the rotor cover for dirt and damages.
- » Insert rotor cover properly into the centering piece and close locking bolts.
- » Close and lock housing cover.
- » Switch on centrifuge.
- » Switch on the inlet of liquids.



When centrifuging substances that are hazardous to health or the environment, it must be ensured that risk to the operator (**wear suitable protective clothing**) and the environment is eliminated. The centrifuged material must be disposed according to the statutory regulations.

Set cleaning interval:

The time needed for the changing of the solid insert depends on the grade of contamination of the liquids.

Open centrifuge in short intervals and check how high the capacity of the insert still is. When having a constant solid flow, determine the time which is necessary to build up a 1-2 cm layer of solids. Depending on this time interval the solids have to be emptied regularly. If the maximum capacity is reached, the liquids are no longer cleaned. Whenever the centrifuge is switched off remove and clean the insert.

PLEASE NOTE:

Empty the insert in any case whenever an unbalance/vibration occurs after the centrifuge is switched on again.

6. Control

6.1 Control Device

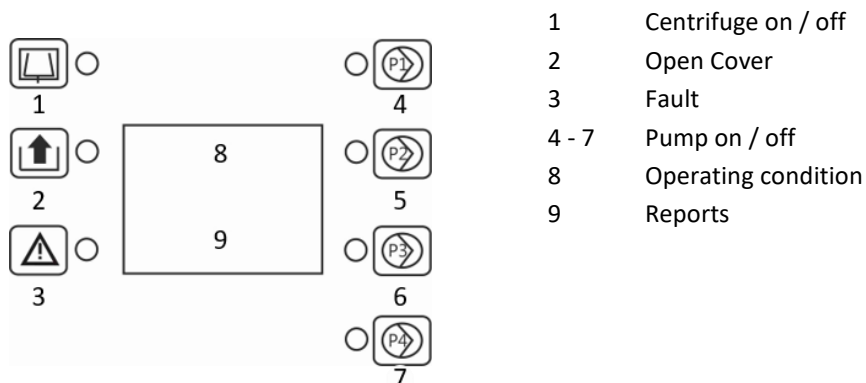

6.2 Description

When the unit is switched on at the main switch the version number and current program number of the printed circuit board will appear on the display.

Program (software) changes may be made in consultation with the manufacturer only.

For version and program number see wiring diagram.

After a few seconds the display switches to the operating state. The display now shows "**centrifuge: stoppage**". For safety reasons the housing cover cannot be opened after switching on the system for approximately 5 min.

Press the key (1) - "centrifuge on/off" key to start up the centrifuge, provided the cover is properly closed. Display shows: „centrifuge in operation", in addition the diode next to the key (1) is lit yellow. Pumps P1-P4 can be turned on using the keys (4-7) "pump on/off". The LED's next to the keys indicate operation of the pumps.

Option: The pumps P1.1 and P1.2 (as supplying pumps of the centrifuge) can be controlled via the level probe or automatically (in the slurping mode). In this case the pumps P1.1 and P1.2 are switched on with a short delay, after the centrifuge has been started.

The housing cover cannot be opened while the centrifuge is running. Press the "centrifuge on/off" key (1) to switch off the centrifuge and pumps P1-P4, the centrifuge's d.c. braking also takes effect. Display shows „centrifuge breaking".

The stoppage of the rotor is detected by a sensor and the d.c. braking is switched off again and the cover interlock is released.

After the braking process, "centrifuge: stoppage" appears on the display, the diode at the "cover open" key (2) lights up green. Press this key to open the housing cover manually. Display shows „centrifuge: stoppage / cover open".

PLEASE NOTE:

If the "open cover" key (2) was pressed the housing cover can be opened within the next 10 seconds (the diode flashes during this time). After the 10 seconds have expired the safety switch locks and the "open cover" key (2) must be pressed again to enable the housing cover to be opened.

If the housing cover is open, neither the centrifuge nor pumps P1-P4 can be switched on.

The centrifuge and the pumps can be switched on and off externally from the machine tool (see wiring diagram). The external control takes priority over the manual control.

In the event of faults the red diode next to the "fault" key (3) lights up, in addition the type of fault is shown on the display (see chapter 8).

6.3 Additional Functions

The setup menu can be used to set other functions such as the program number, the language and the operating time until the centrifuge should be emptied.

PLEASE NOTE:

To open the setup menu, the "fault" key (3) must be kept pressed when switching on the main switch.

All the set functions are displayed in the setup menu. As soon as the - "fault" key is released the display switches back to the normal operating state display.

Program (software) changes may be made in consultation with the manufacturer only. For version and program number see wiring diagram.

- » Selecting the program: Keep the "fault" key (3) pressed. Use the keys (4) + / (5) - to select the program number.
- » Specifying the language: Keep the "fault" key (3) pressed. Use the keys (6) + / (7) - to choose between the German, English and French language.
- » Specifying the operating time or remaining time until the centrifuge should be emptied: Keep the "fault" key (3) pressed, at the same time press the "open cover" key (2) and keep it pressed. Use the keys (4) + / (5) - to specify the number of hours until the centrifuge is emptied. Specify in 0.5h steps up to a maximum of 999h.

If the operating time is activated the set time is shown on the display during normal operation. Display shows e.g.: „centrifuge in operation / remaining time: 0:23 h". If the set time has expired, the diode at the "centrifuge on/off" key (1) begins to flash. In addition, "empty centrifuge" appears on the display. When the housing cover is opened (keep open for at least 15 seconds) the operating time is reset to the set time. When the centrifuge is restarted the counter starts to count down the operating time.

7. Container and system pumps

The shape and size of the container as well as the efficiency of the pump can be designed according to customer's requirements. The operation instructions for the pump can be found in the appendix.

PLEASE NOTE:

The flow rate of the pumps is adjusted using the control valve (ball valve, slide valve, etc.) in the pumps' pressure pipe. The pumps must be adjusted as stated in the technical data (see chapter 3.2). The characteristic curves for the pumps are added to the appendix of these operating instructions. The characteristic curves show the pumping capacity (flow rate) of the pumps, dependent on the pressure, for water. A factor of approx. 0.82 must be taken into consideration for oil.

**The container must not be filled over the maximum level shown in the level indicator.
During filling, the centrifuge and the pumps must be switched off.**

7.1 Adjustment of the Pumps / Level of Purity

PLEASE NOTE:

The level of purity of the centrifuge mainly depends on the flow rate!

The rotary pumps work according to a characteristic curve (please see appendix), which means that the conveying capacity is high, when the pressure is low or the conveying capacity is smaller, when the pressure is higher.

There is a manometer as well as a reducing valve built to the outlet of every pump. Through the pressure shown at the manometer, the corresponding conveying capacity (flow rate) can be determined with the help of the characteristic curve of the pump.

At first, please adjust the system pump SP to the required pressure for the production machine. This is achieved by adjusting the reducing valve built to the outlet of the pump. The corresponding conveying capacity can be determined with the characteristic curve of the pump. The set conveying capacity needs to be cleaned by the unit afterwards. Therefore, do not set it as high as possible but as high as required!

The supplying pump VP in the centrifuge needs to discharge a little more than is supplied by the system pump from the production machine. This is to make sure, that the clean liquids container is always filled and overflows in the contaminated liquids container and never the other way around.

Pumps

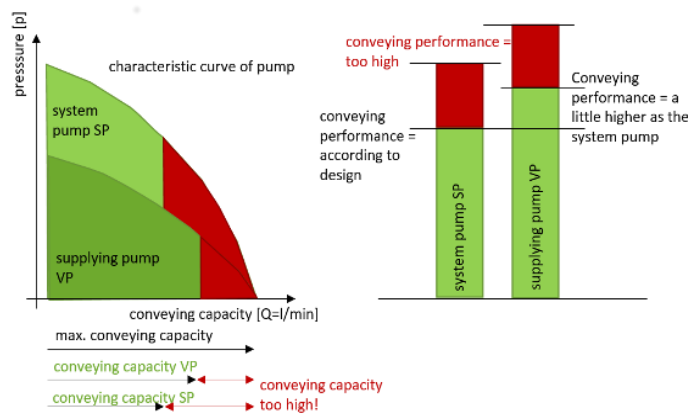

Adjust system pump SP according to the design of the unit. Conveying capacity is depending on the pressure. Operating point inside the green area!

Set conveying capacity of the supplying pump VP according to the adjustments of the system pump SP a little higher. Conveying capacity is depending on the pressure. Operating point inside the light green area!

The adjustment of the supplying pump mainly determines the reachable level of purity. Therefore, do not set it as high as possible but as high as required!

7.2 Level Monitoring (optional)

The level of the liquids in the inlet vessel is monitored using a float switch – see the drawing in the appendix. The maximum level in the inlet container causes a malfunction and switches off the system pump P2x. This fault signal is fed to the terminal for external signal analysis for the machine tool.

7.3 Suction Unit (optional)

Starting in the container of the production machine, the contaminated liquids are led to the cleaning unit MZ 35 through a suction pipe by a suction pump.

There is a pre-filter with a filter basket (mesh size \approx 1mm; optional) installed in between the suction pump and suction pipe, which gathers coarse particles.

Following this, the fine particles are separated from the liquids inside the centrifuge MZ 35. The cleaned liquids leave the centrifuge bowl through the outlet pipe and are led back to the container of the production machine or a different container using pressure.

The leakage liquids flow into the leakage container. Depending on the liquid level, these liquids are sucked off the suction pipe through an automated changeover of the ball valve and are led back to the centrifuge. At the same time, the suction process from the container of the production machine is stopped until the leakage container is sucked empty. The level monitoring as well as the changeover of the ball valve happens through the float switch. If the leakage container is emptied, the suction from the container of the production machine continues.

When switching off the centrifuge, the residual liquids flows out of the rotor through the outlet of the housing into the leakage container while the centrifuge is phasing out and is led back to the centrifuge depending on the liquid level.

There will always be a small amount of residual liquids inside the leakage container. If these liquids are not to be mixed with the liquids of the next container, they need to be drained through the outlet on the bottom of the container manually.

Another float switch inside the leakage container monitors the maximum liquid level in order to prevent an overflow. If the maximum liquid level is reached, the compressed air diaphragm pump or the intake procedure are stopped.

WARNING:

Attention: If the container with the liquids that are being sucked off is installed on a higher level than the machine, the a siphoning effect can occur during standstill.

Danger of overflow! Suction hose and the hose leading back to the container are to be taken out of the container.

8. Faults

In the event of faults the red diode next to the - "fault" key lights up, in addition the type of fault is shown on the display.

8.1 Possible Causes of Faults

- » fault: cover see 8.1 a/g
- » fault: stoppage see 8.1 a
- » fault: centrifuge motor see 8.1 b
- » fault: pump motor (P1-P3) see 8.1 c
- » fault: pump motor of pump 4 = magnetic separator see 8.1 c
- » fault: cooling unit (optional) see 8.1 d
- » fault: maximum level (optional) see 8.1 h
- » fault: minimum level (optional) see 8.1 i
- » fault: vibration (optional) see 8.1 j
- » fault: leakage (optional) see 8.1 k

PLEASE NOTE:

Reset fault signal: Remove fault, then press the - "fault" key to acknowledge the fault signal or switch off the main switch (necessary for stoppage fault only).

a) Centrifuge cannot be started:

- » Power failure.
- » Housing cover not closed, LED at the 'open cover' key flashes.
- » Safety switch is defective (cover fault).
- » Stoppage sensor is defective (stoppage fault).
- » V-belt defective (fault: 'standstill').

b) Motor protection switch or PTC thermistor of the centrifuge operates:

- » Measure power input of the centrifuge's drive motor ('centrifuge motor' fault).
- » Set to nominal current according to motor type label. The motor's power input is affected via the volumetric flow by adjusting the valve in the inlet to the centrifuge or in the pump's pressure pipe.
- » Motor is defective.
- » Check seal (O-ring) in the rotor cover!

c) Motor protection switch of the pump operates:

- » Measure power input of the pump's drive motor ('pump motor' fault).
- » When displaying 'motor pump Px'.
- » Set to nominal current according to motor rating plate. The motor's power input is affected via the volumetric flow by adjusting the valve in the pump's pressure pipe.
- » Motor is defective.
- » Check intake area of pump for dirt, if necessary remove dirt.

d) Motor protection switch of the cooling unit operates:

- » See operating instructions for the cooling unit.

e) Unsatisfactory level of purity

- » Empty solid insert used.
- » Reduce flow rate.
- » Outlet pipe incorrectly set or defective.

f) Centrifuge overflows

- » Reduce flow rate, adjust maximum volumetric flow via the power input of the drive motor.
- » Check seal between rotor and rotor cover.
- » Clean or replace seal and sealing surfaces.
- » Outlet pipe incorrectly set or defective.

g) Cover cannot be opened

- » Power failure.
- » Safety switch is defective ('cover' fault).
- » For safety reasons the cover interlock is not released for approximately 5 min after switching off/on the main switch. The centrifuge can be started.

h) Maximum level in leakage container ('maximum Level' fault)

- » Supplying pump P1 does not work.
- » Level probe in the inlet container is defective.

i) Minimum level in clean container ('minimum level' fault) (optional)

- » Top up with the medium.
- » Level probe in the inlet container is dirty or defective.

j) Vibration ('vibration' fault) (optional)

- » Vibration sensor has triggered. Determine the cause and eliminate it.
- » Empty insert of solids.
- » **Notice:** The triggering of the vibration sensor is a fault signal and is not a signal for the filling ratio of the solids container or the centrifuge.

k) Leakage ('leakage' fault) (optional)

- » Container overflows.
- » Leak in container.
- » Leak in pumps / piping.

With further problems please call us.

Customer service:

Tel.: +49 (0) 7704 922 87-0

E-Mail: info@ruma-zentrifugen.de

9. Operating the Unit

The operator has to respect the established laws and regulations on emissions of all kind like air and noise in particularly water and wastewater for his operating plant and to take appropriate actions before using the cleaning unit.

Only start the centrifuge when all safety and safety-related equipments such as detachable protective devices, emergency stop devices and suction devices are existing and functional.

Report changes in operating behavior immediately to competent body. Stop the unit immediately and lock it if necessary.

Report changes in operating behavior immediately to competent body. Stop the unit immediately and lock it if necessary.

Before switching on/starting the unit, ensure that nobody can be endangered by the starting system.

10. Service

Inadvertent starting of the centrifuge must be prevented by

- » Pulling the power-supply plug.
- » Locking up the principal control elements, remove ignition key.
- » Attaching a warning sign to the main switch.

Individual parts and large assemblies being removed for replacement purposes should carefully be attached to lifting tackle and secured.

ATTENTION



Injuries through falling loads

- Never stand or work underneath suspended loads

PLEASE NOTE:

Use only suitable and technically perfect lifting gear and suspension systems with adequate lifting capacity.

Always tighten any screwed connections that have been loosened during maintenance and repair. Any safety devices removed for set-up, maintenance or repair purposes must be refitted and checked immediately after completion of the maintenance and repair work.

11. Maintenance of the Centrifuge

PLEASE NOTE:

Only use equipment as well as original spare parts from RumA. Equipment and spare parts that are not purchased from RumA, impair the safety, the function as well as the precision of the centrifuge. RumA does not offer any guarantee or liability for misuse or the use of other equipment as well as other spare parts.

After the inspection regulations of the accident prevention regulations a centrifuge must be checked on demand, every 3 years by a specialist after disassembly to its safety at work (see inspection plate on the unit).

The results are entered in the inspection book. The inspection book must be kept at the operation place of the centrifuge and submitted to the technical supervisor.

Do not make any technical changes that may affect the operational safety of the centrifuge, in particular changes on the rotor speed and the mechanical and electrical safety equipment.

In case of faults on the centrifuge an overflow or leakage of the containers must be prevented by e.g. a collecting container, a level monitoring or something like that.

Special maintenance isn't required, due to the construction of centrifuge. Keep housing cover and solid insert in perfect condition. Clean regularly. Whenever strong unbalance/vibration occurs, the centrifuge must be switched off immediately and the cause needs to be eliminated.

Causes for imbalance:

- » Defect insert of solids.
- » Defect peeling pipe.
- » Rotor cover not firmly closed.
- » Defect carrier, uneven distribution of solids in solid insert.
- » Bearing damage.
- » Clean solid insert if necessary.

PLEASE NOTE:

For an optimal cleaning result, we recommend to regularly perform a basic cleaning of the tanks and the unit. Depending on the amount of settled particles, a basic cleaning should be performed at least once per year.

11.1 Dismounting of the Rotor

- » Switch off the inlet of liquids.
- » Switch off the centrifuge and secure against "switching" on.
- » Wait until the centrifuge is standing still.
- » Unlock safety switch of the housing cover.
- » Open the mounted bolts/bracket on the cover.
- » Unlock the rotor cover by opening the locking bolts/screws.
- » Remove rotor cover.
- » Remove solid insert.
- » Remove central cylinder screw (left-hand thread) inside the rotor.
- » Remove bearing head and O-ring.
- » Lift centrifuge rotor with suitable tools.

11.2 Dismounting of the Drive Belt

- » loosen all 4 cylinder screws and the 1 tightening screws at the motor bracket.
- » push motor towards centrifuge, thereby the drive belt is released and can be taken off the disks.
- » apply new drive belt easily and unconstrained without the help of any tools.
- » first stretch the belt with the 1 tightening screws and secure with counter nuts.
- » Then tighten the 4 cylinder screws.

PLEASE NOTE:

After a running in of approx. 15 minutes the drive belt has fixed itself, reached a first tension and needs retightening. A first tension of 0,5 – 1 % relating to the length of the belt is a standard value.

11.2 Level Monitor

PLEASE NOTE:

Check float indicator or level indicator weekly on their function and fouling and clean if necessary (cleaning only in dead-voltage condition, main switch off!).

11.4 Dismounting of the Outlet Pipe

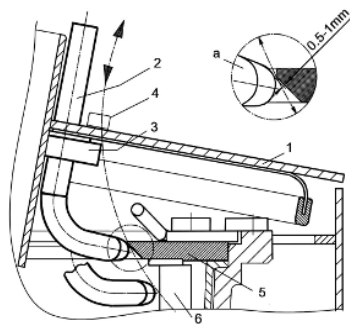

The outlet pipe is placed properly by Ruma.

- » Open housing cover (1), lead outlet pipe (2) with clamping ring (3) from below through the cover.
 - » Slightly bolt up with 4 cylinder screws (4) from above through the cover.
 - » Place outlet pipe (2) so that by carefully closing the housing cover there is a gap of approx. 0,5 – 1mm to the inner surface of the rotor cover (5).
 - » Tighten the 4 cylinder screws firmly.
- » Close housing cover and turn by hand to check if the outlet pipe does not touch rotor lid (5).
 - » Fix outlet pipe.

PLEASE NOTE:

The outlet pipe has to dip tangential into the rotating liquid. Inside the turning rotor and when opening the cover it must not swipe against anything.

12. Disposal

The disposal of the centrifuge, the unit and unit parts must comply with the legal rules. Comply rules for waste disposal (2008/98/EG). Obtain regulations at your national environmental agency or responsible waste management company.