

Versatility  
in ED die sinking

SPIRIT

2

3

4

**AGIE**  
AGIETRON

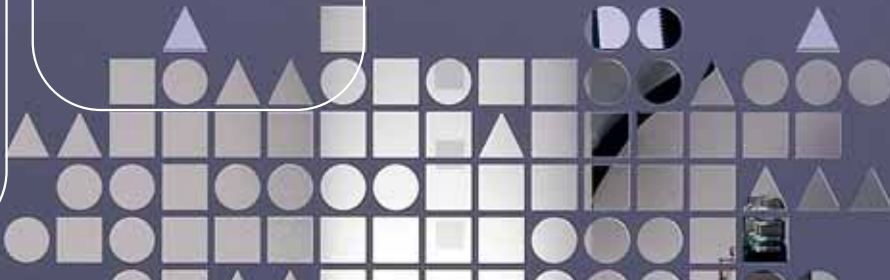

# 2



2

Agietron Spirit 2, 3 and 4 are ED die-sinking machines for fast set-up, simple operation and reliable ED machining.

The Agie EDM know-how of decades is to be found in every Agietron Spirit. In the mechanism, in the control, in the generator. Made in Switzerland.

Agietron Spirit machines can be employed universally. From simple to demanding machining jobs. Agietron Spirit machines in sizes 2, 3 and 4 offer a large number of functions and appliances for this, making these ED die-sinking machines unique in their class.

3

4



AGIE  
AGE THON  
SPIRIT

# Highlights

for versatile ED die sinking

## Simple data input

The operator is guided through the program by self-explanatory symbols. Minimum data about the workpiece and electrode suffice for the control unit to generate the optimal EDM technology.

## Short set-up times

With manual control, automatic measuring cycles as well as good accessibility to the working area, EDM jobs can be started in the shortest time. Clamp, measure, ED machine – Agietron Spirit machines do not require any special prior knowledge of ED die sinking.

## Lowest power consumption

With just 3.8 kW per hour, all Agietron Spirit ED die-sinking machines consume approx. 75% below the average power consumption of competing machines.

## Small drill holes

With the FD (Fine Drill) variant for Agietron Spirit 2, small drill holes can be made with small electrode tubes in addition to normal ED die-sinking applications.

## High removal rate

With new generator technologies which, by means of the intelligent interaction of various functions, achieve removal rates that are above average in all application sectors.

## Great application spectrum

With four controllable and programmable axes, a comprehensive choice of technologies as well as high thermostability, the whole range ED die sinking applications, from simple repair jobs to complex multicavities, can be coped with using the Agietron Spirit 2, 3 and 4.

	2	3	4
<b>Workplace dimensions</b>			
<b>Workplace weight</b>			
<b>Axes travel paths</b>			
<b>Electrode weight</b>			
<b>Smallest roughness</b>			
<b>Electrode magazine</b>			
<b>Fine Drill</b>			

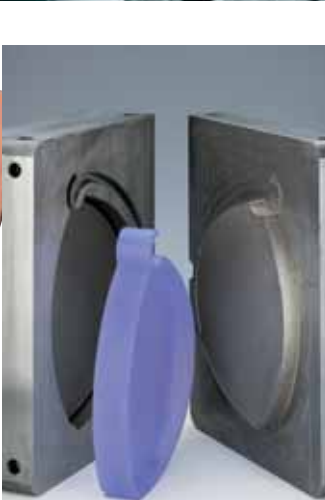

# The generator

for exceptional results

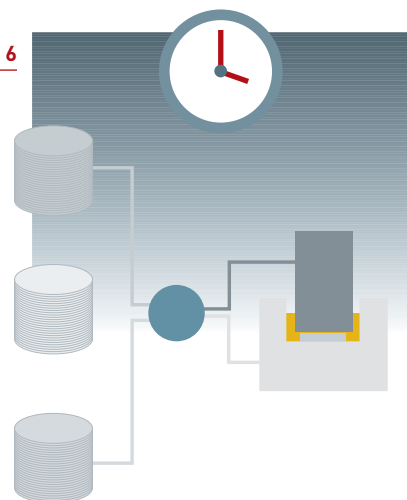

The Agietron Spirit 2, 3 and 4 ED die-sinking machines are equipped with the APG Spirit generator which has the lowest power consumption of all comparable ED die-sinking machines. It sets new quality and performance standards with patented Hyperspark technologies. During all roughing and finishing machining jobs using copper or graphite electrodes, electrode wear is reduced. Productivity is exceptional during standard applications and, even in the case of deep and narrow cavities with poor flushing conditions, a striking improvement in the removal result is achieved with the electrode wear remaining the same:

### To top results fast

With the comprehensive technology database, quality results can be achieved straight away in the case of standard applications, blades, as well with sharp-pointed electrodes, as the EDM technology is optimally matched to the application and generated specifically for the job.

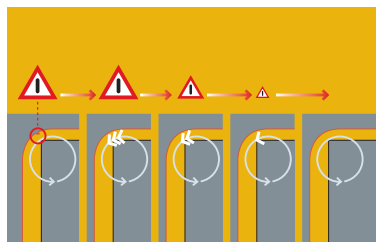
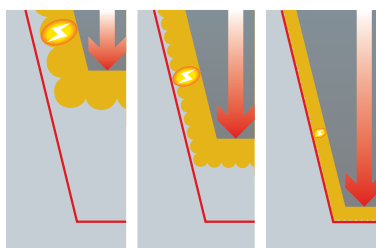
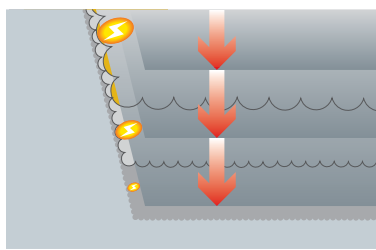
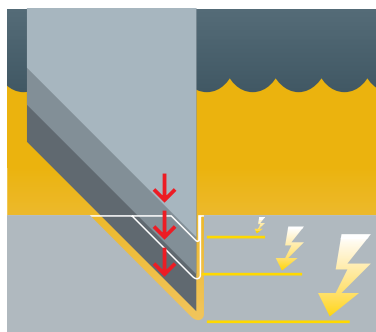

### Low wear

With a fine tuning of low currents and internal voltages, the electrode wear is kept low even in the case of high removal rates.

### Controlled process

With ACC (Adaptive Current Control) and ACO (Adaptive Current Optimisation), new, perfected algorithms have been implemented which react faster and carry out the EDM process reliably, even with a higher removal rate, thus increasing productivity.

### Predictive planetary EDM

With PLS (Predictive Learning System), the EDM conditions during orbital movements are continually stored and analysed. With every oscillation, the process of planetary EDM is then optimised step by step. Cavities are thus shaped exactly and quickly.

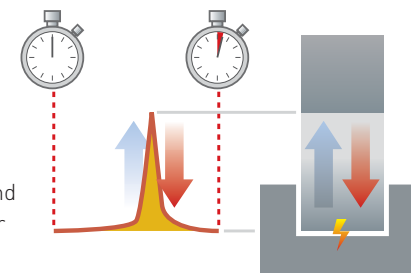

### Intensified removal

With isogeometric impulses, the generator increases the removal per impulse with the same electrode wear, the same spark gap, the same surface roughness and a constant crater geometry. As a result, the removal rate rises strikingly, especially in the case of pre-machined workpieces, reducing the white coating on the ED machined workpiece.

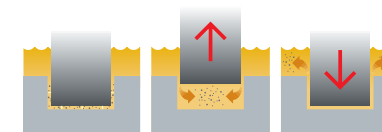

### Intelligent lift-off movements

With dynamic acceleration of the generator's timer function, the lift-off movements are adaptively controlled. ED machining becomes faster and the surface quality is optimised.

# ADG

### Low power consumption

With a maximum of 3.8 kW per hour, Agietron Spirit 2, 3 and 4 have the lowest power consumption. Compared with competing machines, the savings amount to over 75%. An ever more important factor with rising energy costs.

### Performance-enhancing modules

With the optimal 32 A power unit, higher EDM performances are achieved than with comparable competing machines. The finishing module strikingly shortens the time taken for finishing. And with an optimised SF module in the high frequency range, results are achieved when fine finishing lying far below the surface qualities of finishing.

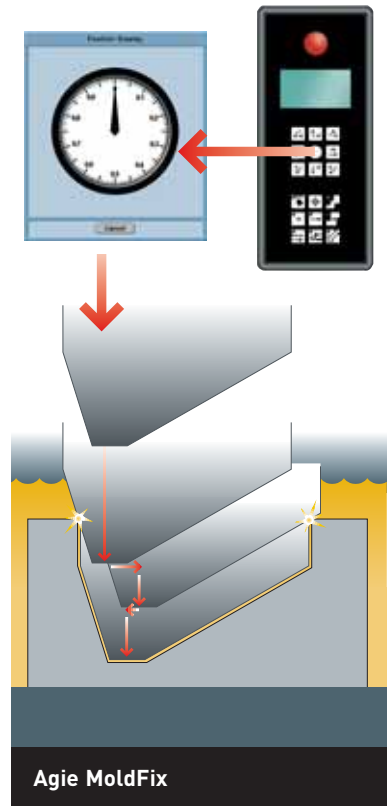

### Manual centring of electrodes

With Jog Erosion, electrodes can be centred into already existing tools. The EDM direction is to move along the main axis and the electrode is centred manually with the other axes. A visual check of the EDM process then permits a perfect alignment of the electrode to the work-piece. A brilliant further benefit for all Agietron Spirit models.

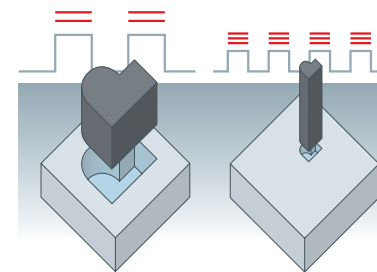

# The control

for short planning and set-up times



The control system of Agietron Spirit 2, 3 and 4 is based on Microsoft Windows and offers the same functionality as on your PC at home. The operator is guided purposefully through all the data input steps necessary for the machining, including the measuring cycles page. The system automatically corrects the workpiece, machining and electrode position. Various machining strategies can be selected by a mouse click:

- 
- 
- 
- 

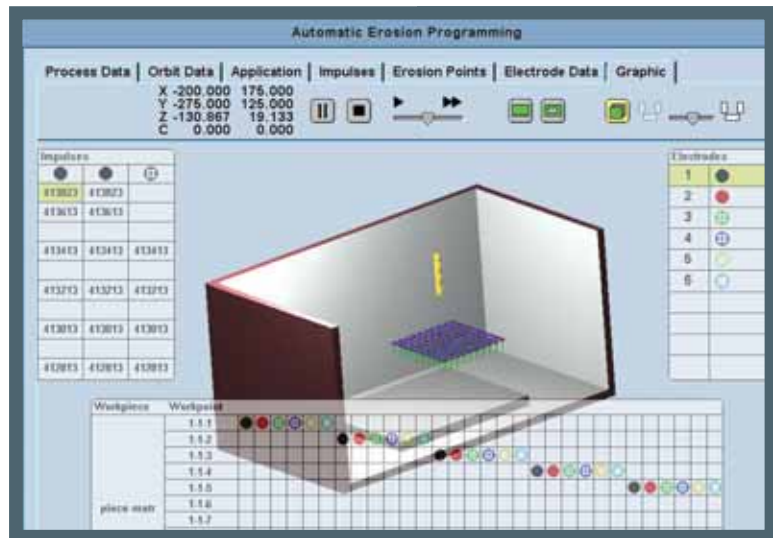

### Controlled ED machining

With windows, that can be called up at any time, the program that has been input, complete with all the movement sequences, can be checked. Even during ED machining the current state of the process can be viewed and optimised if required.

### Clear structures

With an interactive, graphics-aided dialogue, even complex movement sequences in a three-dimensional area become routine. The screen pages are clearly and distinctly structured, and functions can be quickly selected. There are various operator languages available.

### External planning

With Agie Spirit PC, the planning and data input for an EDM job can be carried out on a PC. The operating surface is absolutely identical to the Agietron Spirit 2.

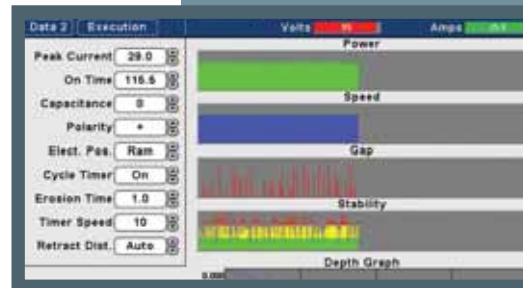

- Measuring cycles
- A Corner touching
  - B Precise edge touching with X, Y and Z-axis
  - C Internal centring
  - D External centring
  - E Electrode alignment
  - F Angular position of workpiece

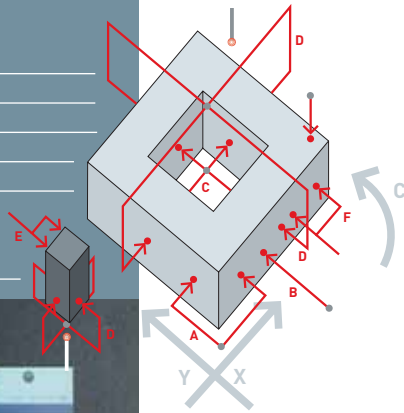

### Automatic measuring cycles

With the touch probe, electrode and workpiece positions are recorded by corner touching, precise edge touching with the X, Y and Z-axis, internal centring and external centring. Agietron Spirit 2 then automatically adjusts the machining program by correcting the workpiece location and electrode position in accordance with the measurement data.

### Rapid target definition

The machining target is defined with a few intuitive inputs and with self-explanatory icons. By selecting and clicking, the positioning, measuring cycles, machining targets and strategies are specified and implemented. The system recognises missing inputs, and operating hints can be called up at any time.



AGIETRON SPIRIT



Job Creation

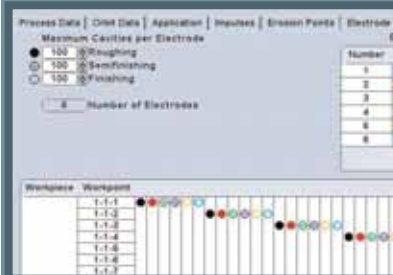

Automatic Erosion Programm

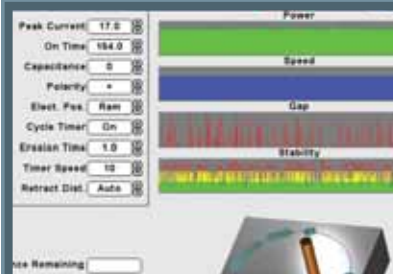

Erosion Process

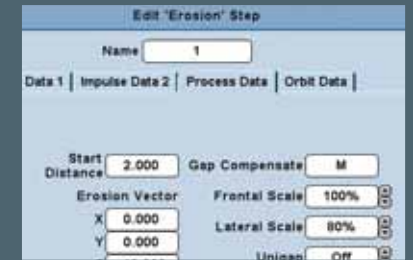

Automatic Erosion Programm



Automatic Erosion Programm



Diagnostic

# The mechanism

for exact forms



Thanks to their compact type of construction, Agietron Spirit 2, 3 and 4 require little floor space. The balance of these ED die-sinking machines' thermal and mechanical stability is shown by the exactly positioned and precisely shaped cavities in the workpiece. An integrated C-axis as well as an electrode magazine make all the Agietron Spirit models into a profitable manufacturing centre:

### Rapid commissioning

The Agietron Spirit 2, 3 and 4 ready for operation with just a few connections. The ED die-sinking machines are delivered complete as a whole and can be transported to their location by fork-lift truck.

### Small space requirement

With the dielectric unit integrated into the machine and the control unit with integrated operating console connected at the side, the Agietron Spirit 2, 3 and 4 impress with their compact type of construction which is manifested by their small floor space requirement.

### Controlled dielectric

High thermal stability is achieved with a heavy duty dielectric/water heat exchanger. A double temperature check and monitoring of the level of the dielectric give process reliability at all times.

### Functional working area

With electrode handling for 4 positions (size 2), for 10 (size 3) or 15/28/56 (size 4) and a large working area, that can be completely utilised with several clamped workpieces, Agietron Spirit machines are excellently suited for multiple machining jobs. Pressure or suction flushing can be used for an efficient EDM process.

### Remote-controlled operation

All the set-up functions can be carried out with a handbox. The axes powered by a high-resolution dc servomotor can be quickly positioned with the handbox, and it is even possible to control ED machining manually.

### Variant for increasing productivity

The Agietron Spirit size 4 can be exclusively retrofitted with an electrode changer for 28 electrodes with a standard clamping chuck or for 56 electrodes with a combination clamping chuck. In this way, the productivity and flexibility can be strikingly improved.

2

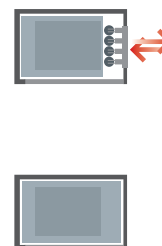

3

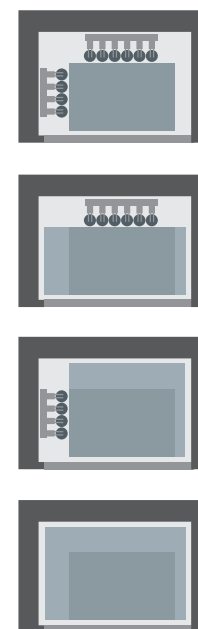

4

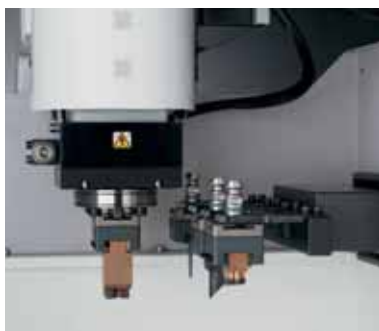
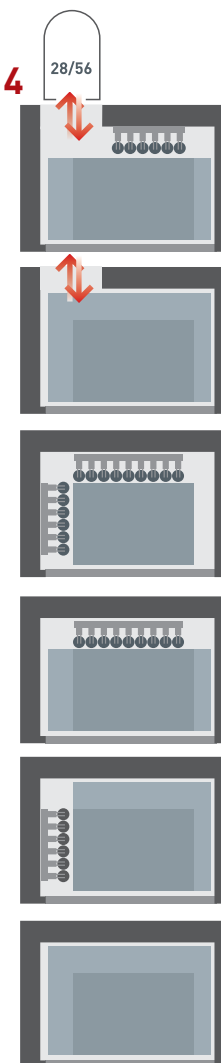



**Good accessibility**

With their swivelling door and large working area, Agietron Spirit can be conveniently loaded from the front. The outstanding feature of all the relevant components for service and maintenance, such as changing the paper filter cartridges, is their optimum accessibility.

**Conform safety**

With electromagnetic screening by complete encasing as well as further measures relevant for safety, the Agietron Spirit 2, 3 and 4 comply with all applicable safety regulations.



### Great variety of forms

With the combined use of the programmable X, Y, Z and C-axes, the whole range of ED die-sinking machining operations is covered. From the simple cavity to the highly complex form in a three-dimensional area: Helical moulds. Spherical moulds. Toothed racks. Flat and 3D-paths. Jaw moulds. Undercuts, also combined with C-axis. Interlinked EDM steps. Drill holes, also combined with C-axes. Multiple moulds, also arranged in circular form. Two and three-dimensional vector widening. Circular widening. Distortion-free cavities with Equimode.

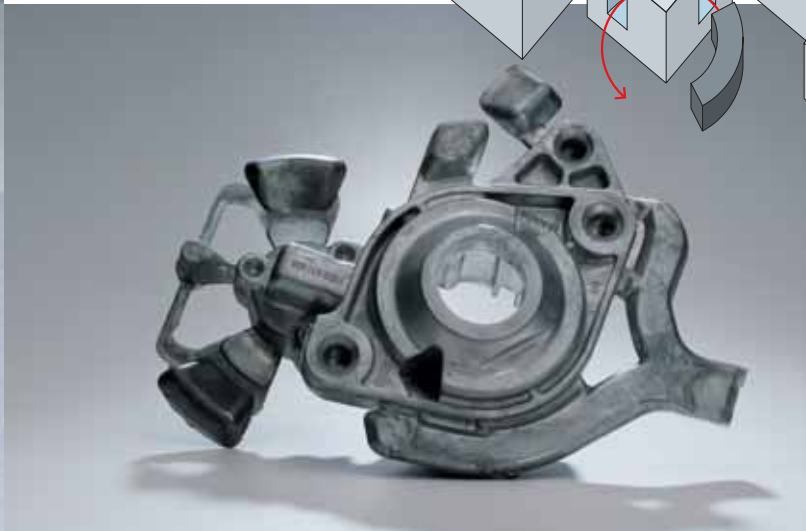
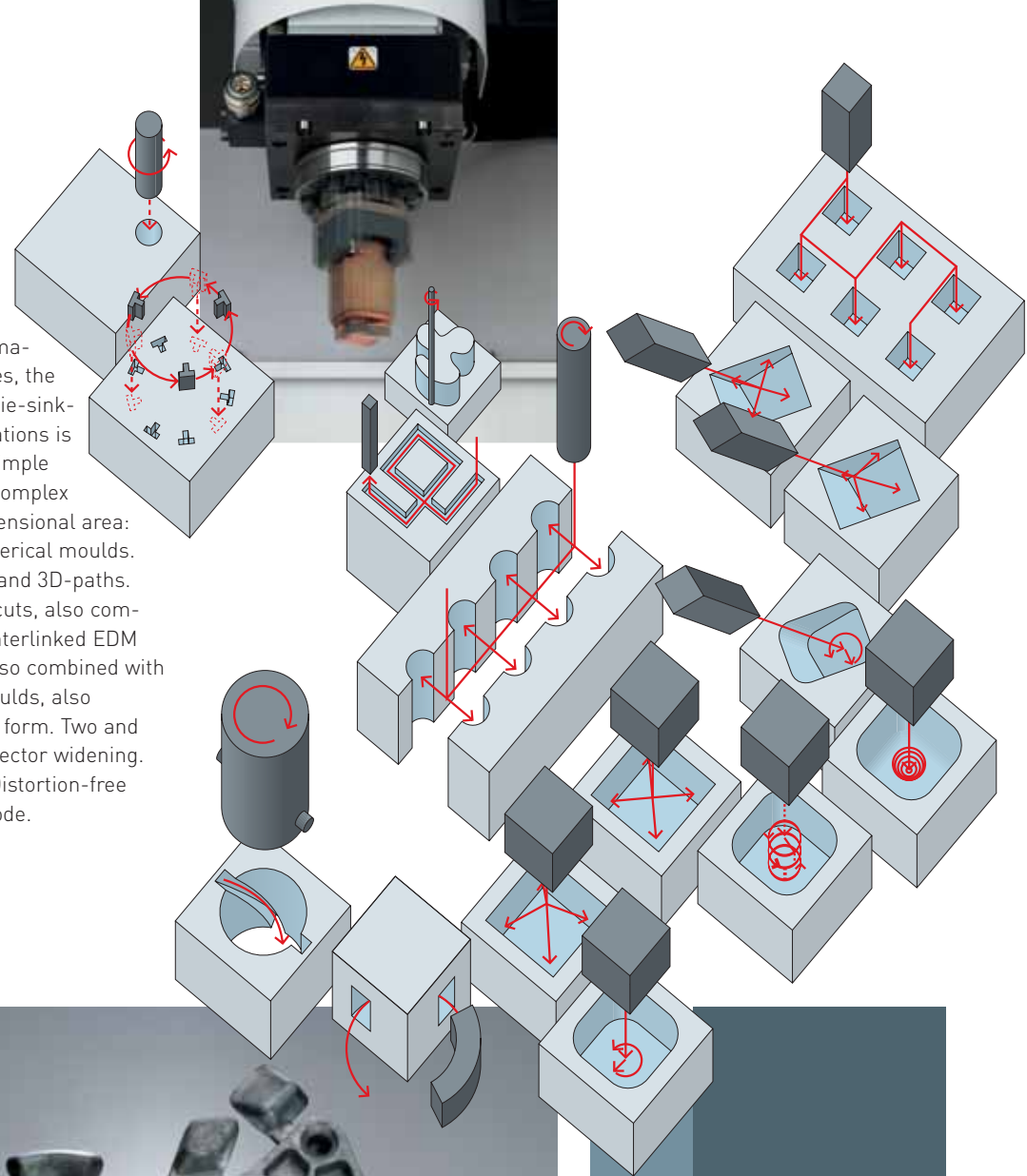

Escape strategy



### Varied machining strategies

With Agietron Spirit, not only are forms simply reproduced in the material, but planetary strategies can be activated in addition, such as equidistant shaping with Agie Equimode, circular widening, 2D or 3D-vector with a free choice of the number of corners or programmable interlinking of EDM movements, as well as path control.

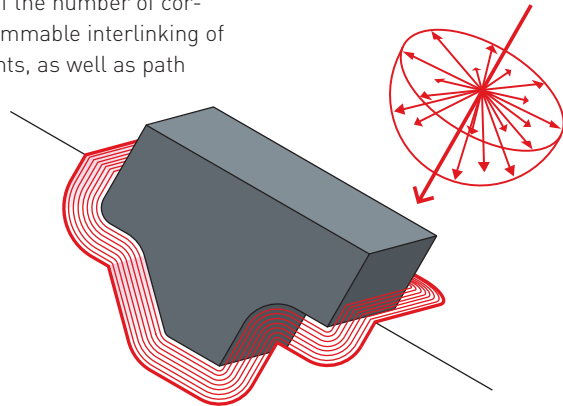

### EQUIMODE for distortion-free 3D-geometries

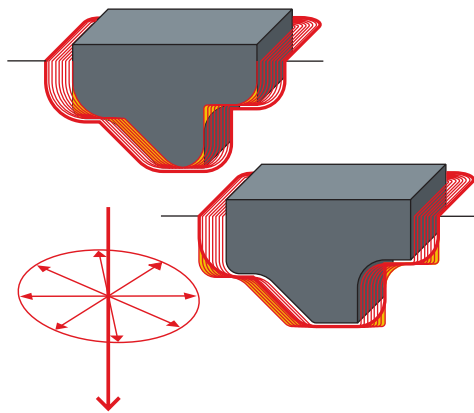

### Automatic implementation of interlinked EDM steps

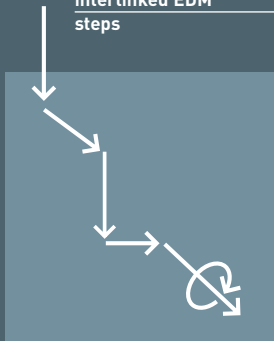

Ø 0.1 mm

### Additional benefit for drill holes

With the FD (Fine Drill) variant exclusive to Agietron Spirit 2, small drill holes can be inserted using small electrode tubes with diameters  $\geq 0.10$  mm, such as are required, for example, as starting holes in ED wire cutting. The rotation and also the high-pressure pump are program-controlled.



# The machine

construction according to model size



## Construction of size 2

With a sturdy C-frame made of fine-grained grey cast iron, the Agietron Spirit 2 is designed for smaller to medium-sized workpiece sizes. The C-axis is integrated into the working head of the Z-axis. Workpieces are positioned  $\mu\text{m}$  exactly in X and Y direction with the cross table, thanks to high-precision spindles and guides. All 4 axes can be controlled synchronously.

## Construction of sizes 3 and 4

With their portal type of construction, Agietron Spirit 3 and 4 are suitable for machining medium to large-sized workpieces. The machine frame made of mineral casting ensures an optimal thermal behaviour, mechanical stability and absorption of vibrations. The portal travels in Y-direction along two pre-stressed, closed guides with ground recirculating ball spindles. The working head on the portal makes the movements in X and Z-direction. The C-axis is integrated into the electrode clamping system in the working head.

## Flexible working area

In next to no time, the working area of every Agietron Spirit can be enlarged to a maximum by dismantling the electrode magazines so that, depending on the model size, the largest possible workpiece in each case can be machined.

## Precise axis drives

With high-resolution servomotors and a transducer for dynamically sliding movements by all axes, an  $\mu\text{m}$ -exact positioning is achieved with all Agietron Spirit models. The positioning speed is 0.9 m/min.

## Compact design

A unit is formed in each case made up of the machine and dielectric unit, and also the control and generator. Both are coupled together and are delivered as one whole on a frame. All Agietron Spirit machines can thus be manoeuvred with little effort and, thanks to their small floor space requirement, find their place even in narrow rooms. Commissioning could not be simpler with a total of just 4 connections required.

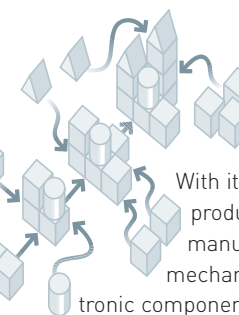
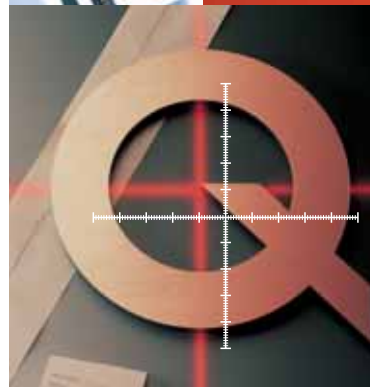

## Made in Switzerland

With its ultramodern production plant, Agie manufactures all the mechanical and electronic components relevant for the precision itself. A sturdy type of machine construction, large-dimensioned spindles and guides of the axes, an efficient CNC control, as well as a fully digitised generator with patented hyperspark EDM technologies turn all Agietron Spirit machines into an investment in ED die sinking machines with a guaranteed future. The manufacturer's know-how of decades goes into every Agietron Spirit. In the mechanism, in the control system, in the generator.

## Certified quality

Agietron Spirit pass through exactly prescribed checking and testing stations and must ED machine a range of practice-related inspection pieces. The time taken for the complete certification of each individual Agietron Spirit is thus far greater than what we need for the actual assembly.

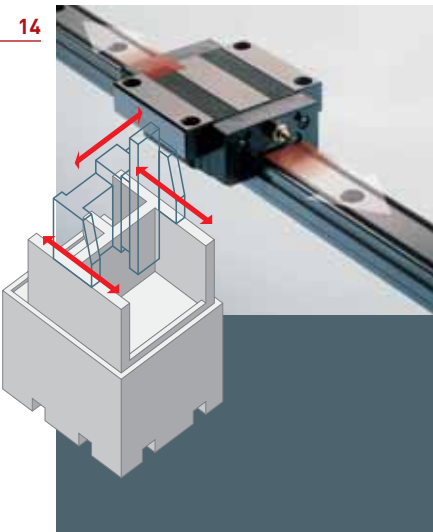



# The versatility of the functions

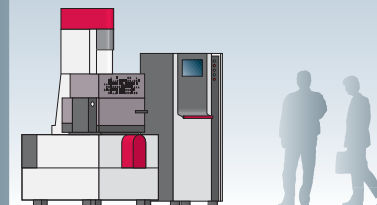

AGIETRON SPIRIT 2

<b>Axes travels</b>		X/Y/Z axes	300 x 250 x 250 mm (11.8 x 9.85 x 9.85 in)
<b>Workpiece</b>	Max. use of working space	Width x depth x height	630 x 400 x 185 mm (24.8 x 15.7 x 7.3 in)
	Max. dimensions	With integrated electrode magazine	500 x 400 x 185 mm (19.68 x 15.7 x 7.3 in)
	Max. weight		200 kg (141 lbs)
<b>Electrode</b>	Max. weight	With automatic chuck	25 kg (55 lbs)
			120 kg (265 lbs)
<b>Work area</b>	Table to quill distance	Minimal / maximal	190 - 440 mm (7.5 - 17.4 in) [1]
	Worktank	Bath level programmable	225 mm (8.85 in)
<b>Machine table</b>	Clamping surface	Length x width	400 x 300 mm (15.7 x 11.8 in)
	Clamping plate with hole pattern grid 50 mm (1.95 in)		■
<b>Integrated C axis</b>	For positioning, rotation and helical erosion	Rotation	0-40 RPM
	Max. working current	Rotating / stationary	72 A / 72 A
	Max. electrode weight		25 kg (55 lbs)
<b>Integrated electrode changer</b>	Quill equipment	Integrated automatic chuck standard type	▲
	Electrodes magazine		▲ ELM 4 right
	Electrode changer		-
<b>Universal high performance generator</b>	Fingers	For automatic chuck standard type	▲
	AGIE APG-SPIRIT "Advanced Power Generation"	Type	integrated
	Process adaptation according to the degree of difficulty	ACC/ACO automatic	■
Selection and automatic adaptation of the technology	AEP (Automatic Erosion Programming)	■	
Servo system for maximum ED machining efficiency	AGIE APG Fuzzy	■	
Accurate depth and homogeneous surface in fine finish	UNIGAP automatic	■	
Frontal and lateral compensation of undersize	GAP automatic	■	
Database for User-Technology	User-Technology	■	
Polarity	Programmable	■	
<b>Performances</b>	Max. removal rate Vw mm <sup>3</sup> /min	◆ Copper / Steel at 72 A / 550 mm <sup>3</sup> /min	■
		◆ Graphite / Steel at 72 A / 600 mm <sup>3</sup> /min	■
	Best roughness	◆ Ra	0.2 µm (RMS 9.6 µin)
<b>Flushing</b>	Electroerosive polishing	AGIEBRIL	■
	Optional power stage 32A for best use with graphite electrodes	◆ Increase to 104A, removal rate Gr/Steel	-
	Number of connection	Tank / quill	3 / 1
<b>Dielectric unit</b>	Pressure, suction		■ 1
	Integrated	Charge volume	300 l (79.2 gal)
<b>Filtration</b>	Cartridge filters	Canisters / cartridge filters	1 / 2
		Filter quality	3-5 µm
		Filter autonomy	40 h at 32 A
<b>Cooling</b>	Cabinet with air cooling and dielectric with water / water heat exchanger		■
	Cabinet with water / air and dielectric with water / water heat exchanger		▲

- ◆ According to AGIE setting values
- Standard
- ▲ Variant: not retrofittable
- Option: at choice

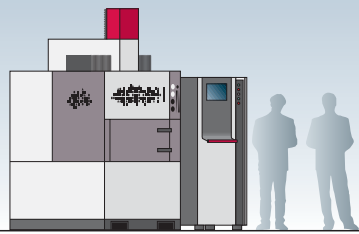

**AGIETRON SPIRIT 3**

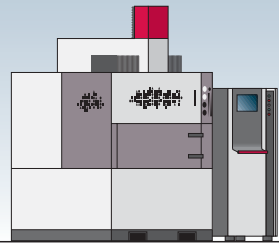

**AGIETRON SPIRIT 4**

1m

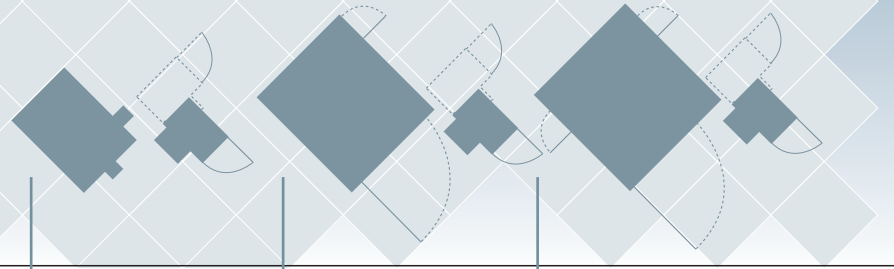

2

3

4

550 x 400 x 350 mm [21.7 x 15.7 x 13.8 in]	700 x 500 x 400 mm [27.6 x 19.7 x 15.7 in]
960 x 650 x 255 mm [37.8 x 25.6 x 10 in]	1100 x 750 x 370 mm [43.3 x 29.5 x 14.5 in]
760 x 450 x 255 mm [29.9 x 17.7 x 10 in]	920 x 550 x 370 mm [36.2 x 29.5 x 14.5 in]
1000 kg [2200 lbs]	2000 kg [4409 lbs]
50 kg [110 lbs]	80 kg [176 lbs]
80 kg [176 lbs]	113 kg [250 lbs]
170 - 520 mm [6.69 - 20.47 in] [1]	215 - 615 mm [8.5 - 24.2 in] [1]
295 mm [11.61 in]	410 mm [16.14 in]
700 x 500 mm [27.55 x 19.68 in]	870 x 550 mm [34.25 x 21.65 in]
■	■
0-40 RPM	0-40 RPM
72 A / 72 A	72 A / 72 A
50 kg [110 lbs]	50 kg [110 lbs]
▲	▲
■ ELM 10	■ ELM 15 (▲ ELM 22)
-	▲ ELW 28 / 56
▲	▲
integrated	integrated
■	■
■	■
■	■
■	■
■	■
■	■
■	■
■	■
■	■
0.2 µm (RMS 9.6 µin)	0.2 µm (RMS 9.6 µin)
■	■
● 1000 mm <sup>3</sup> /min (0.055 in <sup>3</sup> /min)	● 1000 mm <sup>3</sup> /min (0.055 in <sup>3</sup> /min)
3 / 1	3 / 1
■ 1 / 1	■ 1 / 1
500 l [132 gal]	840 l [221.9 gal]
2 / 4	2 / 4
3-5 µm	3-5 µm
40 h at 32 A	40 h at 32 A
■	■
▲	▲

Notes:  
[1] Depending on the clamping chuck,  
e.g. with System 3R Macro

System	2	3	4
Dimensions of the complete unit (w x d x h)	1850 x 2100 x 2360 mm [72.8 x 82.7 x 92.9 in]	2800 x 2800 x 2690 mm [110.23 x 110.23 x 105.9 in]	3000 x 3000 x 2865 mm [118.1 x 118.1 x 112.79 in]
Dimensions of the control cabinet (w x d x h)	760 x 520 x 1740 mm [29.92 x 20.47 x 68.5 in]	760 x 520 x 1740 mm [29.92 x 20.47 x 68.5 in]	760 x 520 x 1740 mm [29.92 x 20.47 x 68.5 in]
Distance floor / clamping level	1050 mm [41.33 in]	914 mm [35.98 in]	914 mm [35.98 in]
Net weight	1280 kg [2822 lbs]	3300 kg [7276 lbs]	4000 kg [8819 lbs]
Weight ready-to-run	1550 kg [3417 lbs]	3800 kg [8378 lbs]	4800 kg [10582 lbs]
Line power	4.7 kVA	4.7 kVA	4.7 kVA
Line voltage	3 x 400 V	3 x 400 V	3 x 400 V
Mains frequency	50/60 Hz	50/60 Hz	50/60 Hz
Compressed air	7 bar, 5 m <sup>3</sup> /h	7 bar, 5 m <sup>3</sup> /h	7 bar, 5 m <sup>3</sup> /h
Cooling capacity required	2-3 kW	2-6 kW	2-6 kW

#### Operation and data input

Remote control for manual axes movement X/Y/Z/C and  
general functions for work preparation

Operator interface system Spirit 2

Control unit integrated

Operating system

Operating mode

CPU's

Storage capacity

Servo controlled axes

Units of measurement

Command format

#### Moduls and functions

Fine drill module

Smallest programmable step X/Y/Z/C axes

Visualisation of erosion data

Program structure

Pickup cycles for automatic determination of workpiece position and electrode

Reference definition and correction piece - electrode

Orbital movement in space for every application

Module for contouring

Pressure flushing and suction

Help functions, explanations with text and graphics

Machining simulation and positioning

Languages

Data storage media

Interfaces for external peripheries

■ JOGBOX with LCD Display

■ 15" flat panel display, mouse

■ CNC SPIRIT guided interactive input

■ Windows / multitasking

■ Multiprocessor

■ Pentium for CNC and operator interface

■ 20 GB RAM

■ X/Y/Z/C axes

■ mm/inch

■ Absolute, incremental

▲ For Spirit 2 - Fine holes with electrodes from diam. 2 to 0.1 mm

■ 0.001 mm / 0.001°

■ Graphics display with: power, stability, speed and depth

■ Automatic Erosion Programing (AEP - guided)

■ Intuitive programming with icons

■ Automatic saving

■ Vector, circular, continuous spherical, vector 2D/3D, EQUIMODE,  
continuous circular / spherical

■ Geometry 3D

■ Manual

■ Manual integrated in the operating system

■ Program check without erosion

■ English, DE, CN, CZ, DK, ES, FR, IT, KR, JP, NL, PL, PT, RU

■ USB; CD-ROM

■ 1 x RS232C; 1 x Parallel; 1 x LAN; 2 x USB

# The address

for over 50 years  
of ED machining

Electro-erosion, also called EDM – Electric Discharge Machining, is a young technology. A little over 50 years old. Just as young as Agie. A technology which has been decisively influenced and shaped by Agie in this time. What is EDM? By using electrical discharge machining, conductive materials of any hardness can be machined with an accuracy of down to a thousandth millimetre, practically without any mechanical effect. This makes EDM a key technology in the manufacture of demanding dies and blanking tools which are used for the mass production of parts made of plastic, metals and glass. Objects from our everyday life: toothbrushes, mobile phones, PET bottles, computers, cutlery, ski boots, ball-point pens, car components, toys, implants, instruments – the list could be continued at will and proves impressively that EDM is a dynamic technology with unlimited future potential.





**Advice.** Competent and experienced sales engineers, who are quite near to you, advise you all round the topic of electric discharge machining. No questions are left open.

**Information.** Agie updates its web site [www.agie.com](http://www.agie.com) constantly, publishes interesting customer applications in the magazine "experience" and, even after the sale, informs about the latest products with brochures and flyers.

**Caring.** Agie has technical consultants deployed world-wide who implement practice-oriented application, automation, hardware and software solutions and also facilitate the entry into ED machining.

**Training.** Agie prepares individual instructions for every EDM system so that productive EDM jobs can be commenced already shortly after commissioning.

**Documentation.** Agie supports the operator effectively with practice-oriented documentation for use and maintenance in printed and electronic form.

**Hotline.** Agie routinely solves approx. 90% of all problems directly by phone on the hotline open all round the clock.

**Service.** Agie ensures world-wide optimal functioning and utilisation of your Agie EDM system with its continuously trained service technicians.

**Readiness for delivery.** Agie offers a 24-hour service and maintains a large store for fast deliveries with 97 percent availability of original spare and wearing parts, consumables and additional equipment.

**Original parts.** Agie guarantees the best EDM results with its original spare and wearing parts. All the machining technologies and works details are based on this.



EUROPE NORTH	AGIE CHARMILLES LTD NORTH VIEW UK-COVENTRY CV2 2SJ UNITED KINGDOM TEL +44 2476 538 666 FAX +44 2476 530 023 WWW.AGIE-CHARMILLES.CO.UK info@agie-charmilles.co.uk	GREAT BRITAIN NORTHERN IRELAND
	AGIE GMBH WWW.AGIE.DE info@agie.de	GERMANY
	AGIE SALES LTD CH - 6616 LOSONE TEL +41 (0)91 806 90 30 FAX +41 (0)91 806 90 33 WWW.AGIESALES.COM info@agiesales.com	SWITZERLAND AUSTRIA BENELUX SCANDINAVIA SLOVENIA CENTRAL AND EASTERN EUROPE BALKANS MIDDLE EAST SOUTH AFRICA
	GALIKA AG WWW.MAC-CIS.RU	CIS
	AGIE CHARMILLES SP.Z.00 WWW.AGIE-CHARMILLES.PL info@agie-charmilles.pl	POLAND
EUROPE SOUTH	AGIE CHARMILLES SPA BU AGIE WWW.AGIE.IT info@agie.it	ITALY
	AGIE CHARMILLES SAS WWW.AGIE.COM agiefrance@agie.fr	FRANCE
	AGIE CHARMILLES SA WWW.AGIE.COM info@agie.es	SPAIN PORTUGAL
AMERICA	AGIE LTD 575 BOND STREET LINCOLNSHIRE ILLINOIS 60069 - USA TEL +1 800 438 50 21 FAX +1 847 478 57 80 WWW.AGIEUS.COM info@agieus.com	USA CANADA SOUTH AMERICA MEXICO
ASIA	ON THE WEB SITE: WWW.AGIE.COM	JAPAN SINGAPORE INDIA PAKISTAN CHINA KOREA

Agie Charmilles Group



# AGIE

AGIE SA  
CH - 6616 LOSONE  
TELEPHONE +41 (0)91 806 91 11  
TELEFAX +41 (0)91 806 92 60  
WWW.AGIE.COM  
info@agie.com

All rights  
to changes  
reserved.

© AGIE.  
The machine  
design is  
registered,  
1997.

500.029.578  
April 2006  
Printed  
in Switzerland.