

# Cummins Generator

**Prime: 510KW/638KVA**  
**Standby: 560KW/700KVA**

## Technical Data

Model		700kva
Prime power	kva	638
	kw	510
Standby power	kva	700
	kw	560
Rated voltage line to line	V	400
Rated current	A	920
Maximun sound level	dB@7m	75

## Engine-Cummins

Model		KTAA19-G6
Aspiration		4 cycle,in-line,6 cylinders,turbocharged,air to air cooled
Fuel system		Direct Injection Cummins PT
No. cylinders		6
Displacement	L	19
Bore*Stroke	mm	159x159
Compression ratio		13.9:1
Rated speed	r/min	1500
Governor		Electric system
Engine wet weight	kg	1633
Engine idel speed		575-650
Fire order		1-5-3-6-2-4
Start Motor	V	24

## Exhaust System

Max exhaust back pressure	kPa	10
Standard exhaust pipe diameter	mm	127

## Air intake System

Max inlet pressure (Dirty air)	kPa	6,2
Max inlet pressure (Clean air)	kPa	3,7

## Fuel System

110% load(Standby power)	L/h	146,1
100% load(Prime power)	L/h	133,9
75% load(Prime power)	L/h	99,5
50% load(Prime power)	L/h	59,5
25% load(Prime power)	L/h	22,6
Fuel capacity for silent genset	L	1000
Fuel capacity for open genset	L	1000

## Lubrication System

Idle speed oil pressure	kPa	138
Governed speed oil pressure	kPa	345-483
Max Oil temp	°C	121
Oil capacity	L	50

## Cooling System

Coolant capacity--Engine only	L	23
Max coolant friction head to engine	Kpa	68,9
Max water temp standby/prime powe	°C	104/100

## Standard Features

Engine(Cummins ENGINE)	●
Radiator 50°C max,fans are driven by belt	●
24V charge alternator	●
Alternator: single bearing alternator IP23	●
insulation class H/H	●
Standard auto control system	●
One set of air filter, fuel filter, oil filter	●
Main line circuit breaker / ACB	●
Base fuel tank	●
Two 24V batteries, rac and cable	●
Exhaust system(Ripple flex exhaust pipe)	●
Exhaust siphon, flange, muffler	●
User manual	●
Battery charge	●
Water heater	●

## Options

Alternator heater	<input type="radio"/>
PMG	<input type="radio"/>
Water oil separator	<input type="radio"/>
Daily fuel tank	<input type="radio"/>
Remote control panel	<input type="radio"/>
Automatic transfer switch/ATS	<input type="radio"/>
Switch box	<input type="radio"/>
Standard: ●	Options: ○

## Alternator

Model		TAL-A473-F
Alternator Brand		Leroy Somer
Phase		3
Voltage	V	400
Wiring Type		6 wires
Bearing		1
Power factor		0,8
Frequency	Hz	50
Prime power	KVA	660
Exciter Type		Brushless, self-excitation
Voltage regulation	%	±0.5
Protection Grade		IP 23
Insulation grade		H

## Controller-Deepsea

Model	DSE 7320
7 digital display	
Built-in governor and AVR control	
Base load (kW export) functionality	
Mains (utility) de-coupling protection	
Generator power (kW, kVA) monitoring	
Overload (kW & kV Ar) protection	
Emergency stop	
Start failure	



## Unit Dimensions(Basic unit)

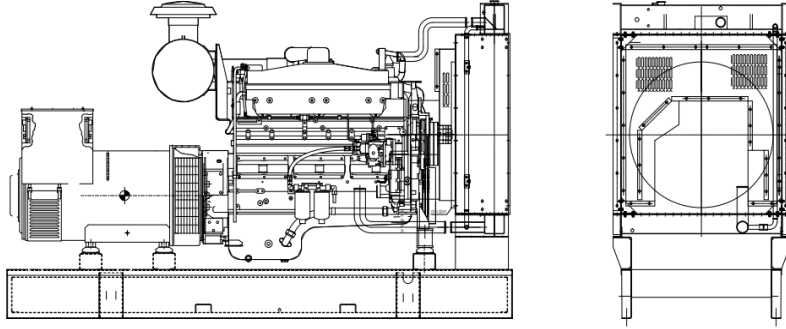

### Open Type

L*W*H	mm	3600x1650x2000
Weight	kg	4850

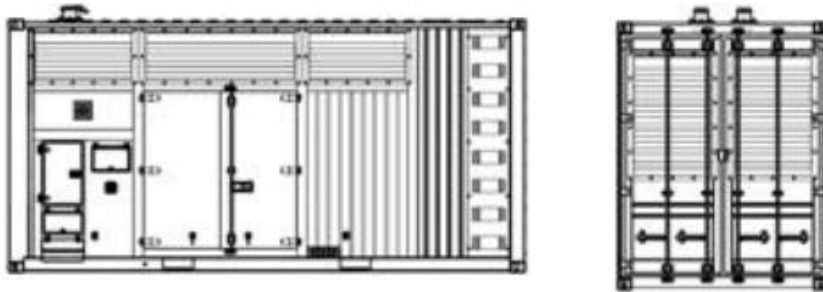

### Silent Type

L*W*H	mm	4800*1950*2500
Weight	kg	5850

## Warranty

### Cummins Engine

12 months from date of purchase or 1000 hours.

### Generator

12 months from date of purchase or 1000 hours

(whichever comes first).