

FINISHED BATCH TANKS (2-OFF)

PXL REF: V005A

V005B

ABLE REF: PXL19785-3

Ø4000mm ID Design

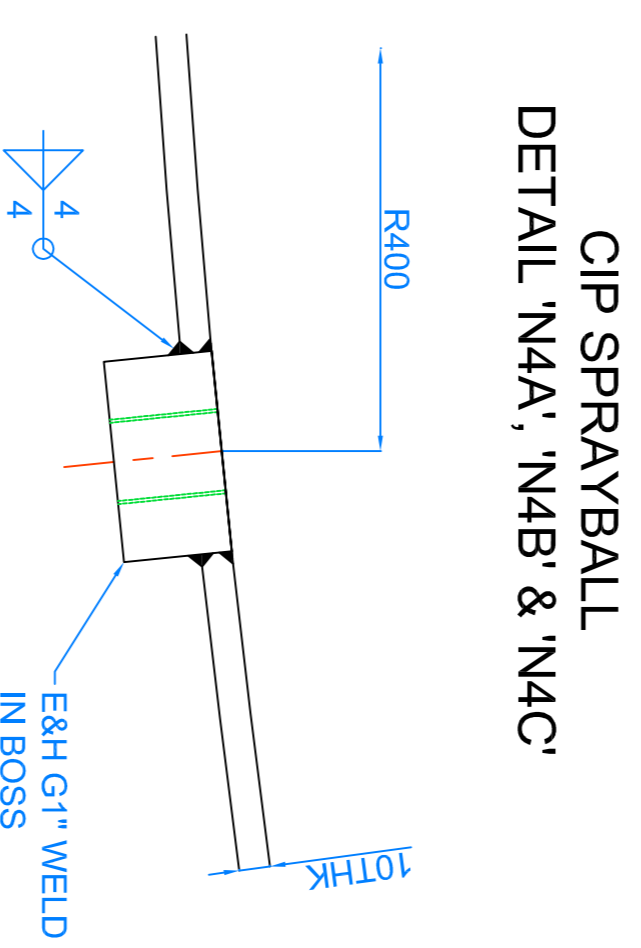
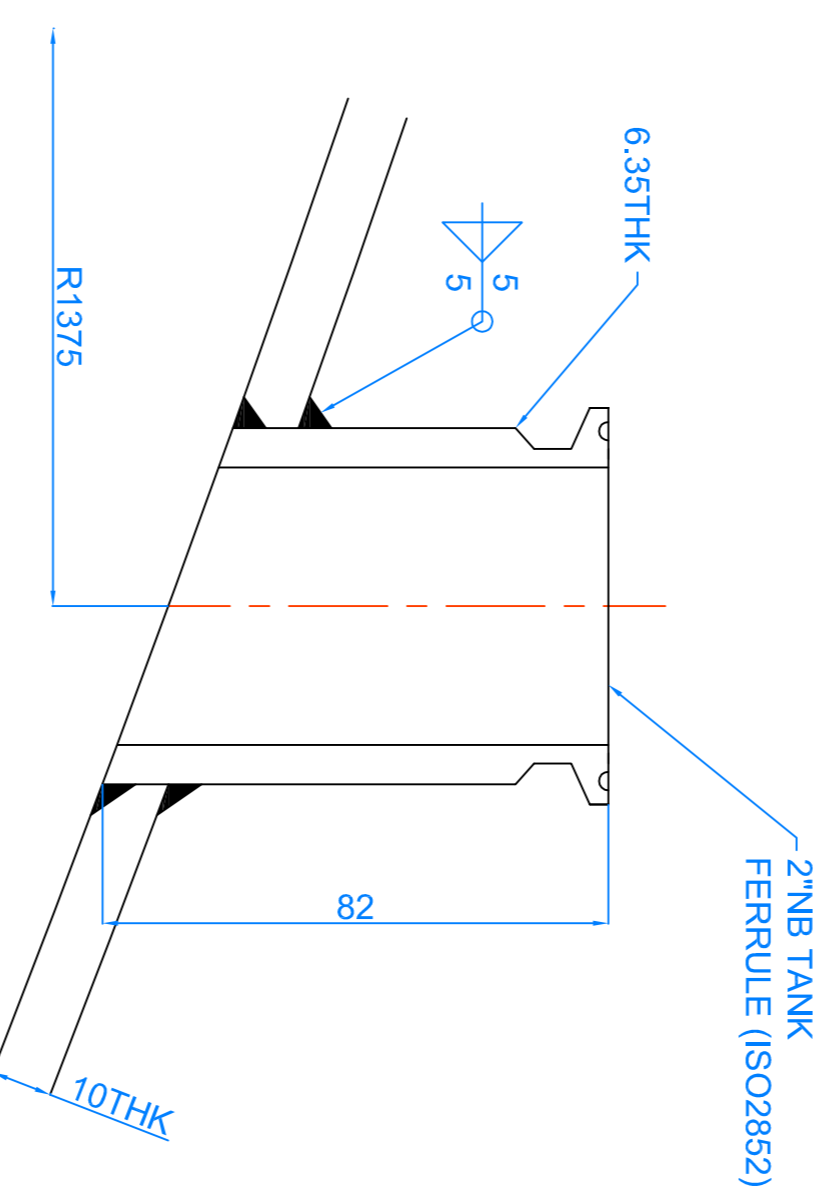
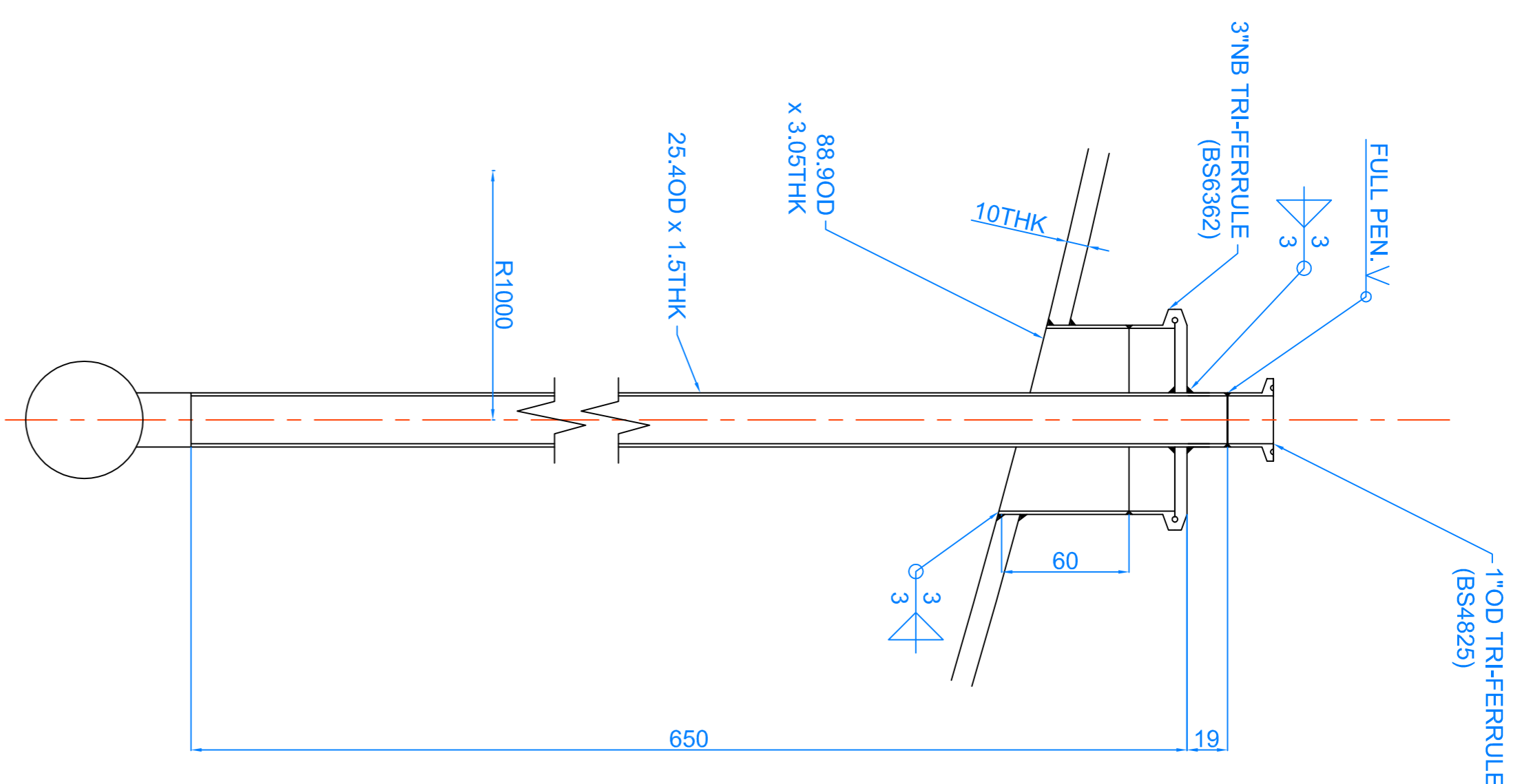
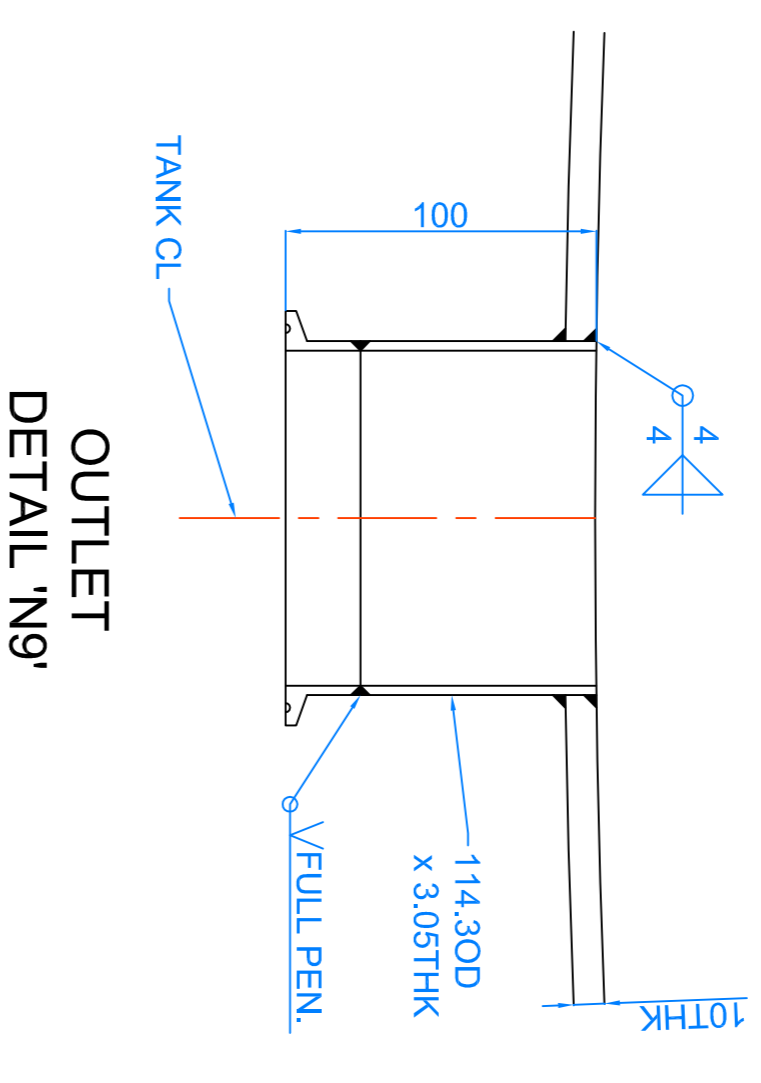
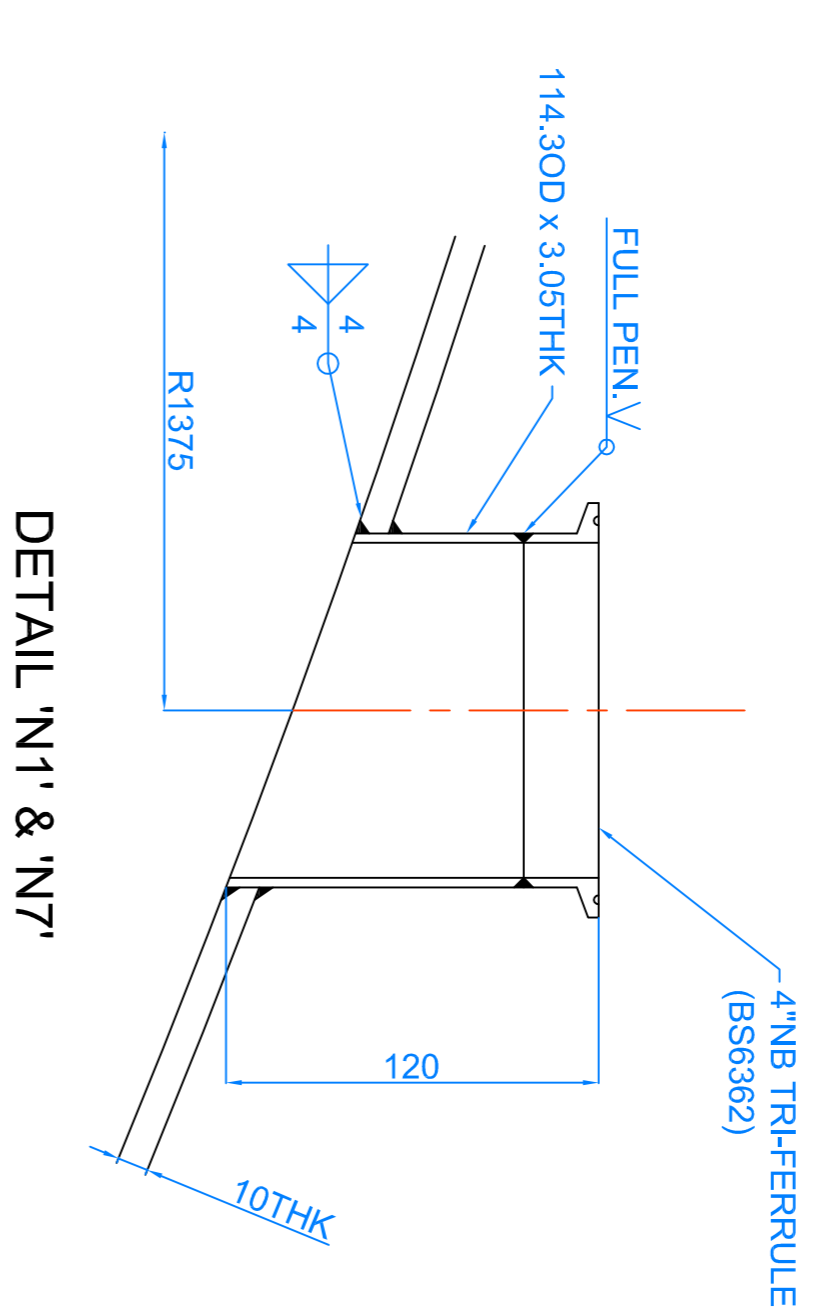
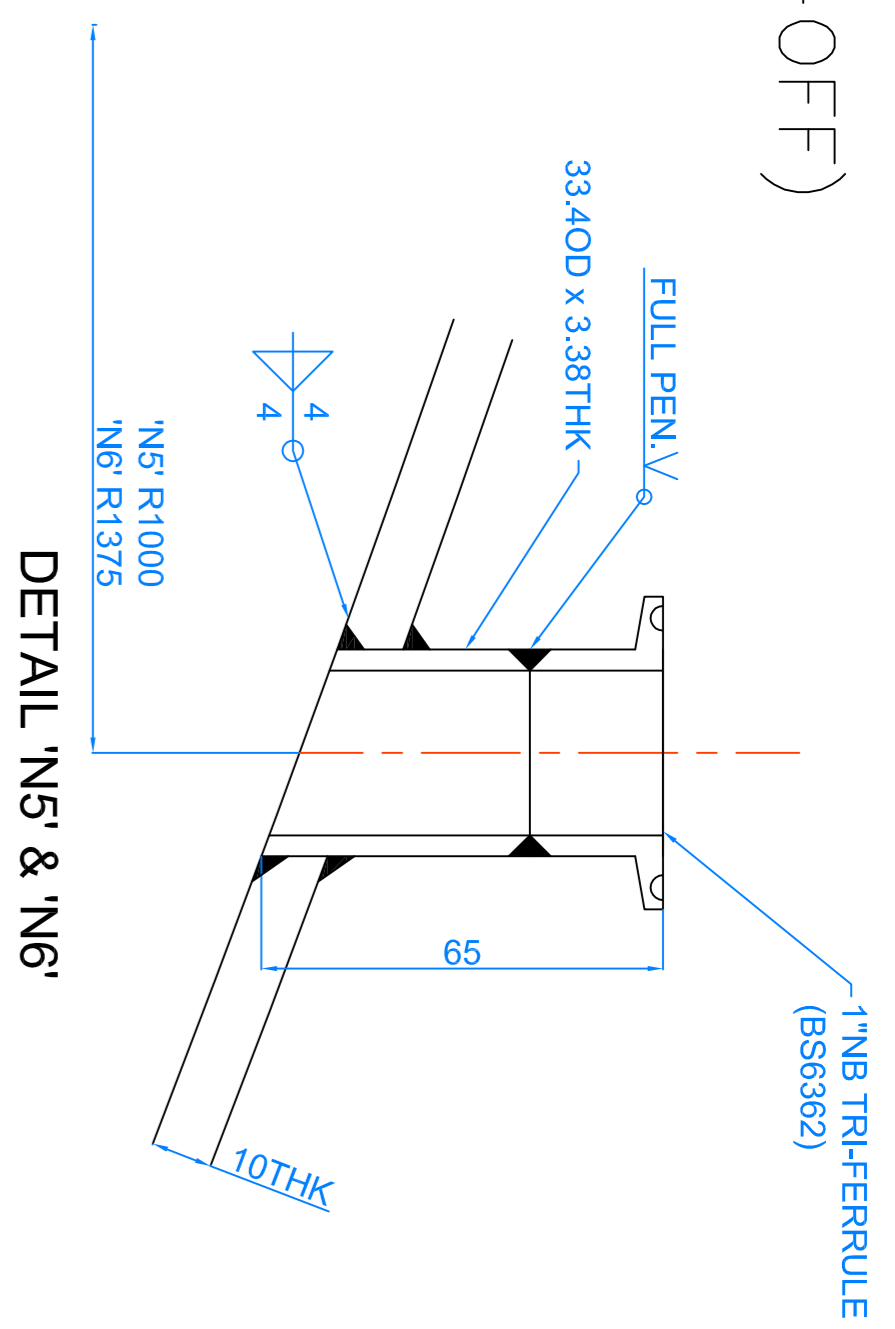

SUPPORT LEGS
DETAIL 'N16'

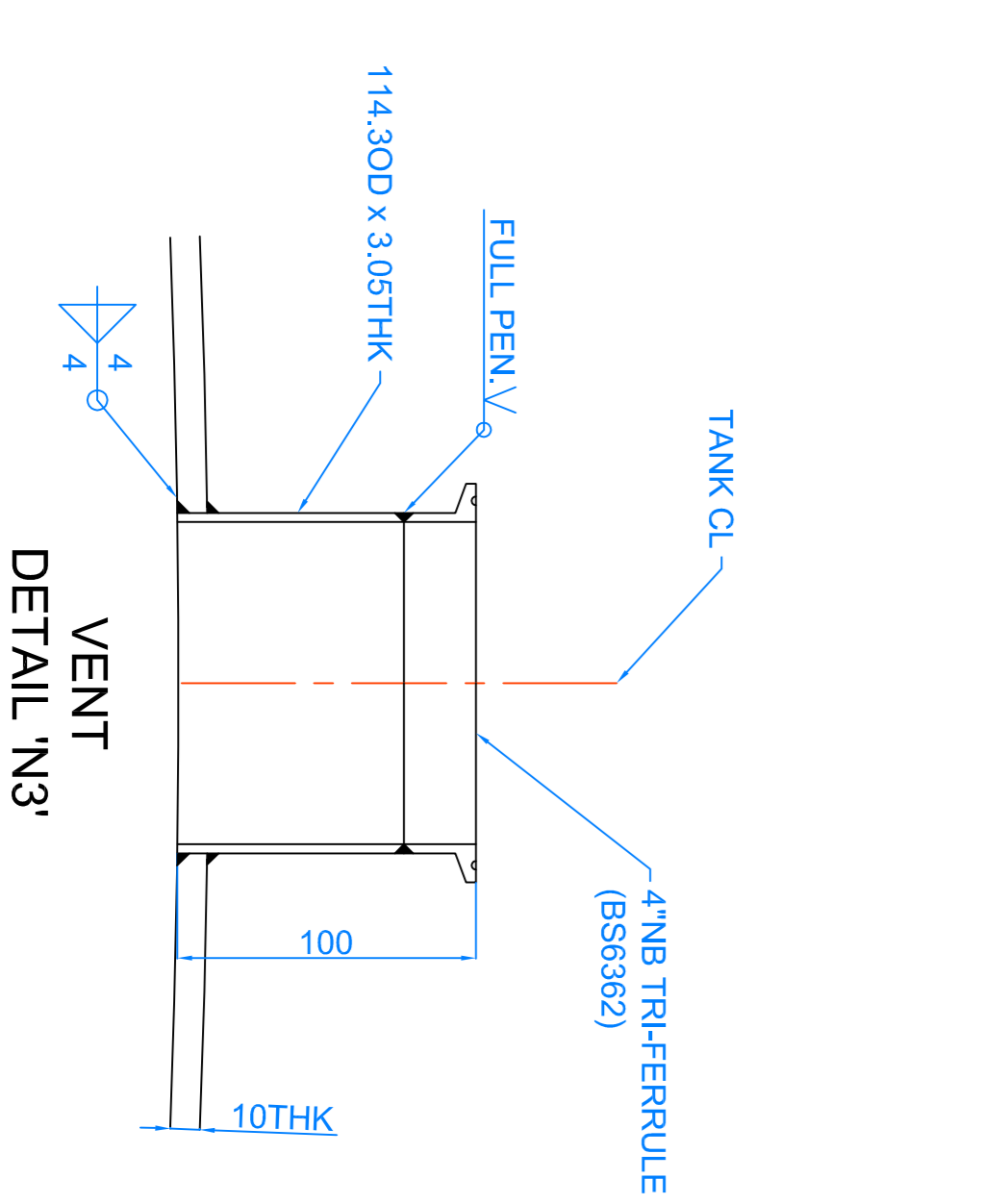
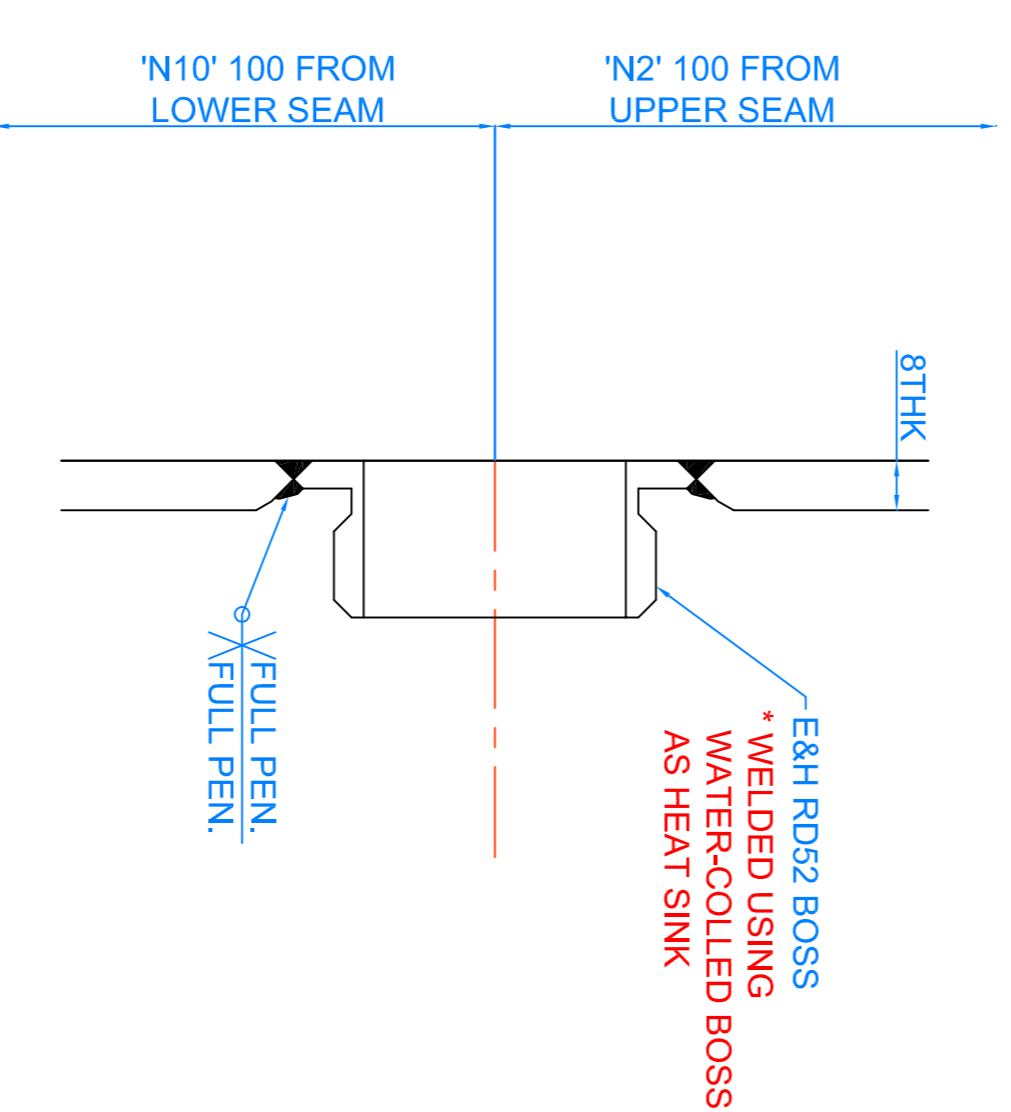
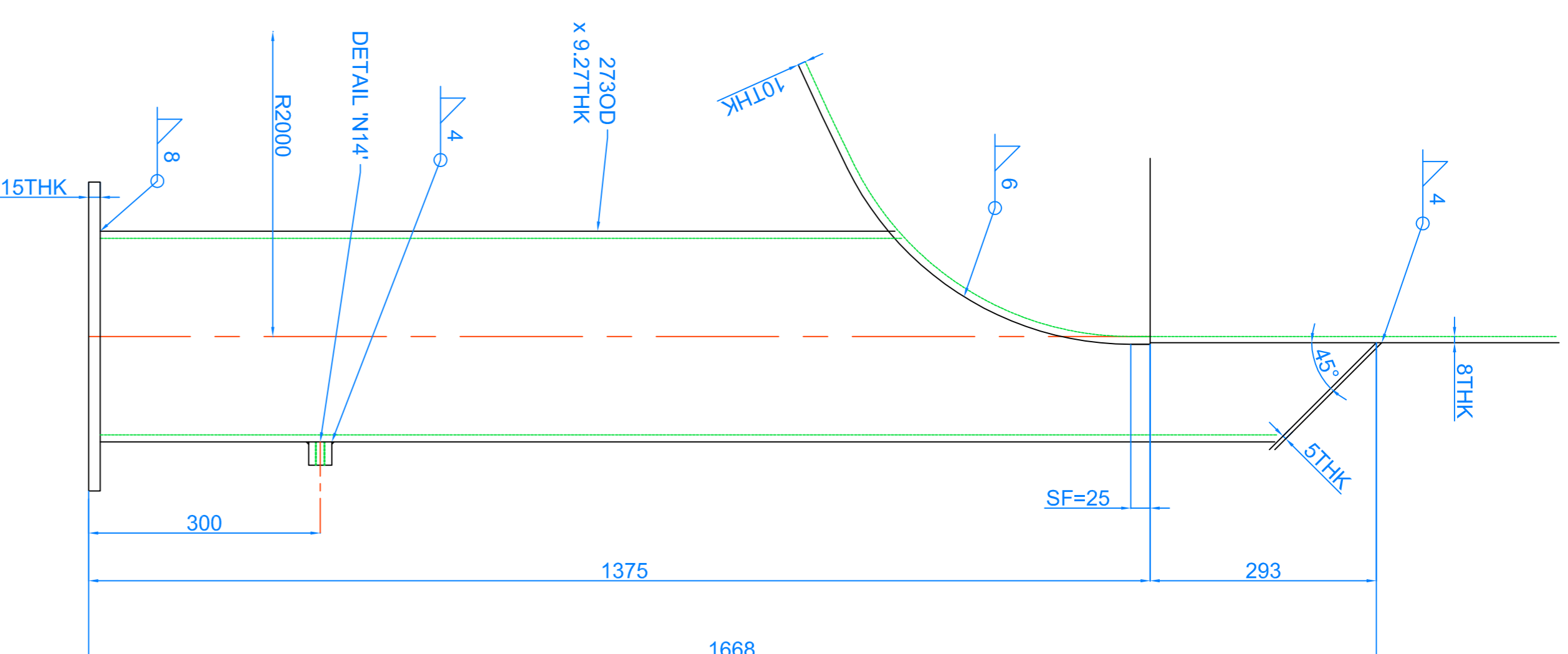

MANWAY GRILL

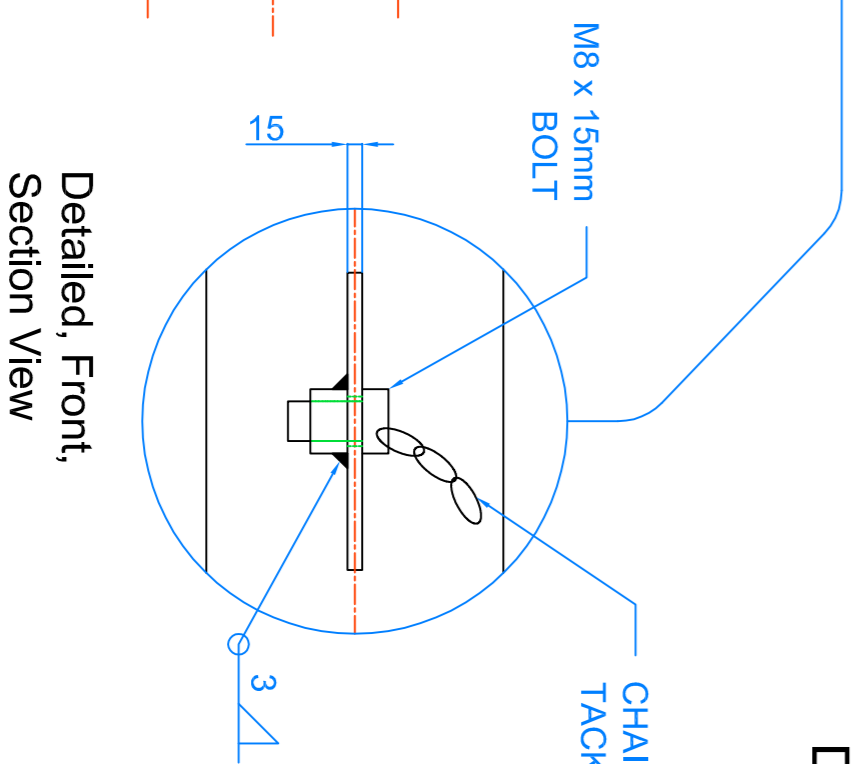
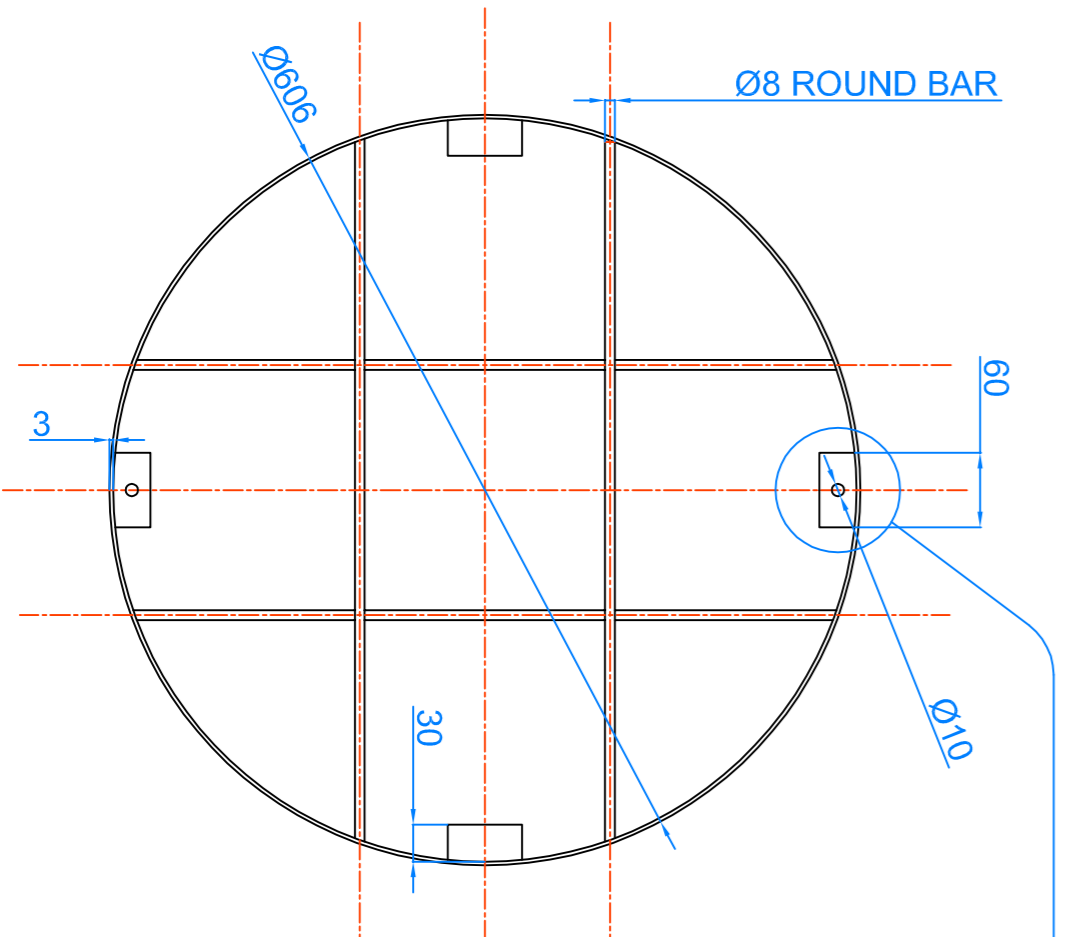

MANWAY
DETAIL 'N8'

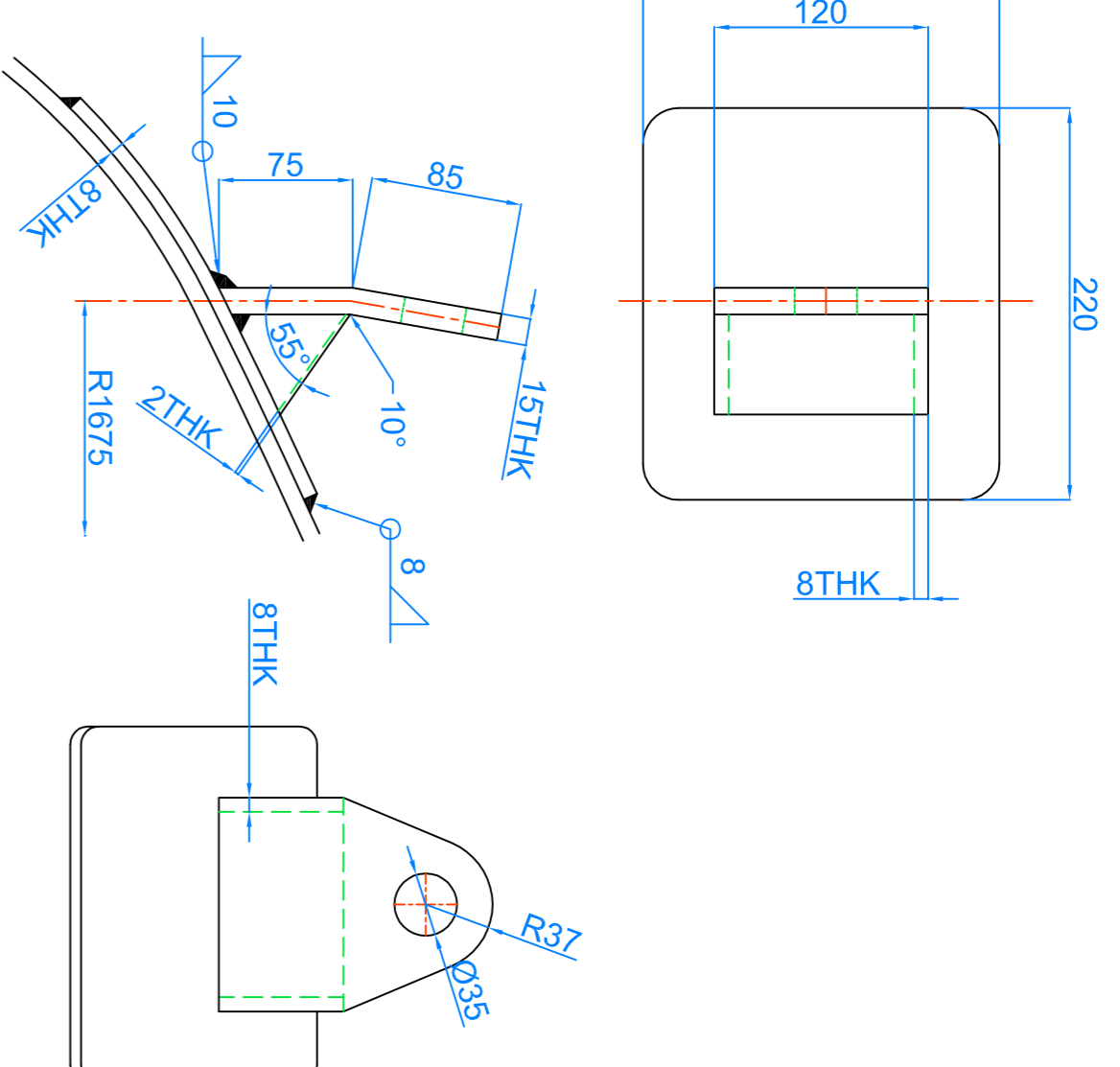
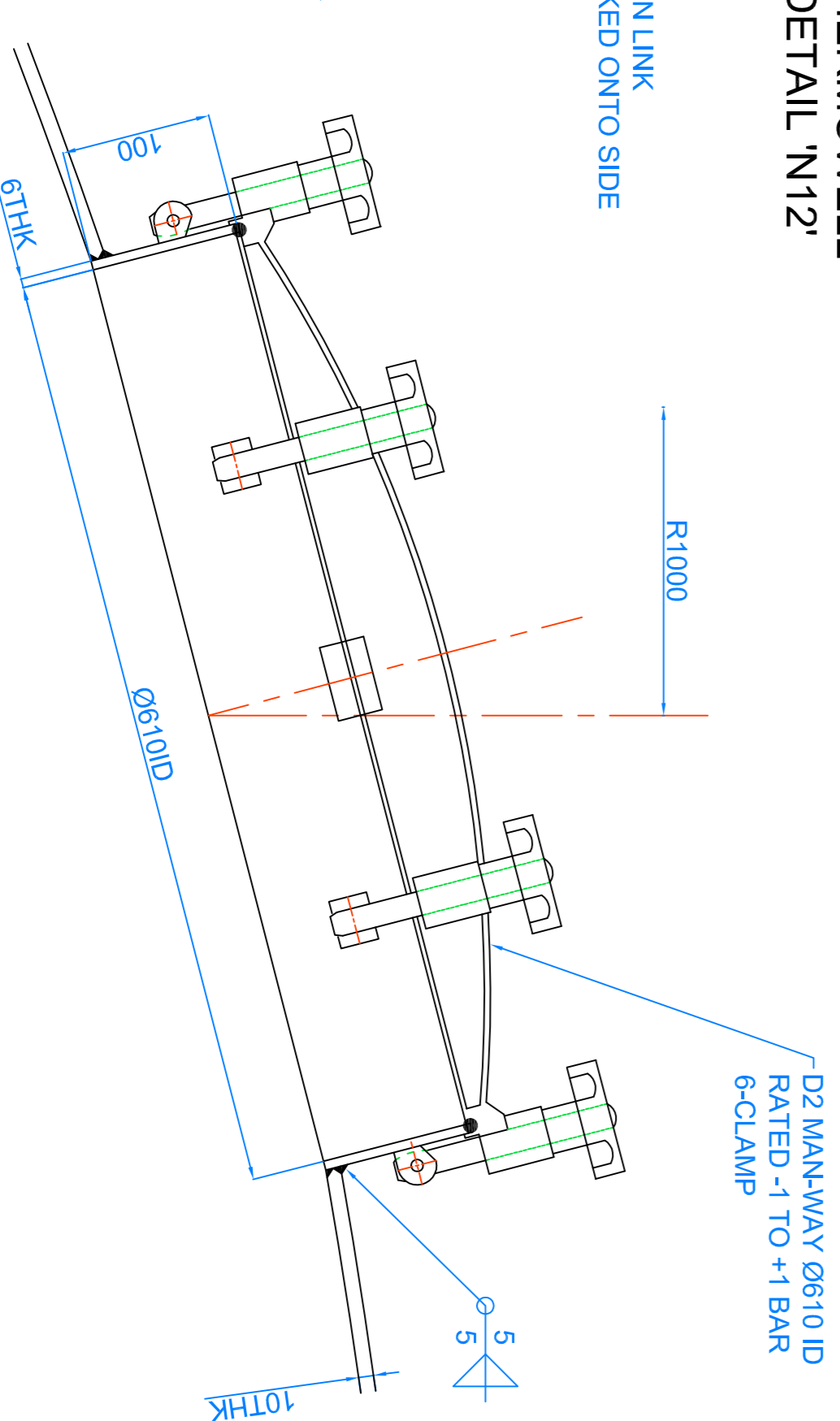

MANUFACTURED BY
ABLE ENGINEERING
CADLEY HILL ROAD, SWADLINCOTE, DERBYSHIRE, DE11 9EQ
TEL: (01283) 227160 FAX: (01283) 222375
www.able-engineering.co.uk

DESCRIPTION: FINISHED BATCH TANK 1/2
BPL TAG NUMBER: V005A/ V005B
BUILT FOR: PX LTD.
FABR. SERIAL No: PXL19785
DESIGN CODE: POS500/2018, CA1.3
SEF
PRESR. CATEGORY: ATMOSPHERIC
VESSEL WORKING PRES.: -1 TO +0.45 BAR.G
VESSEL DESIGN PRES.: HYDROSTATIC
VESSEL TEST PRES.: -1 TO +0.45 BAR.G
VESSEL DESIGN TEMP.: -10C to 100C
MATERIAL OF CONSTR.: 316L STAINLESS STEEL
WORKING VOLUME: 30,000L
FABRICATED WEIGHT: 4,250 KG (EMPTY)
OPERATING WEIGHT: 50,140 KG (FULL)
TESTED: AUG 2021

NAMEPLATE
DETAIL 'N13'

REV. No.	DESCRIPTION	DATE	INT.
A	DETAIL SHEET ADDED	24.03.21	B.P
P2	VESSEL HEIGHT EXTENDED	26.01.21	B.P
P1	PRELIMINARY DESIGN	28.10.20	B.P



CADLEY HILL ROAD, SWADLINCOTE, DERBYSHIRE, DE11 9EQ
TEL: (01283) 227160 FAX: (01283) 222375
www.able-engineering.co.uk

THIS DRAWING & DESIGN IS THE PROPERTY OF ABLE ENGINEERING AND IS ONLY ALLOWED TO BE USED BY EXPRESS PERMISSION & LICENSE FROM ABLE ENGINEERING.

DRAWN BY:	B.S.PAVEY	DATE:	28.10.20	SCALE:	N.T.S.
CLIENT:	PX Ltd	CLIENT O/Nr.:	3500404064		

TITLE:	SANITISER BATCH TANKS (2-OFF)	DRAWING No.:	AEC12113	REV.:	A
		SHEET No.:	2 OF 2		