

patent pending AZ 20 2010 002 285.1

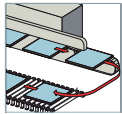

ZHR 340 BOOMERANG® Return Conveyor

Return conveyor for the one-man operation at one-sided edge-banding machines. Thanks to an improved air-cushion table and a modified taking-over, the range of parts is enormously increased

- Large variety of parts
- Optimum part handling thanks to an air-cushion table without ball valves
- High capacity also in case of small workpiece gaps

- Pusher for capacity increase in a new design
- Belt cleaning (simple) included in the standard
- New safety equipment

ZHR 30

ZHR 540

ZHR 340

ZHR 05

ZHR 02

ZHR 01



LIGMATECH Automationssysteme GmbH
Phone: +49 37323 160
info@ligmatech.de · www.ligmatech.de

Assembly | Packaging | **Automation**



ZHR 340 BOOMERANG® Return Conveyor

Workpieces coming from the basic machine are taken by outfeed belts running synchronously to the basic machine and then transported to an air-cushion table.

For stabilization, especially for small parts and for cross processing of larger parts, the supplied top pressure device is used.

By means of a pusher and the inclination of the air-cushion table the workpieces slide onto a transport belt and are transported on this belt. At the end of the return system the workpieces are fed to the operator on a non-driven roller conveyor.

For the flexible use, the machine can be operated in four standard work modes:

- air-cushion table always lowered without pusher operation
- air-cushion table always lowered with pusher operation
- air-cushion table in lifting operation (at top during pick-up, then lowering) with pusher operation
- air-cushion table always at top for manual pick-up (no return of workpieces)

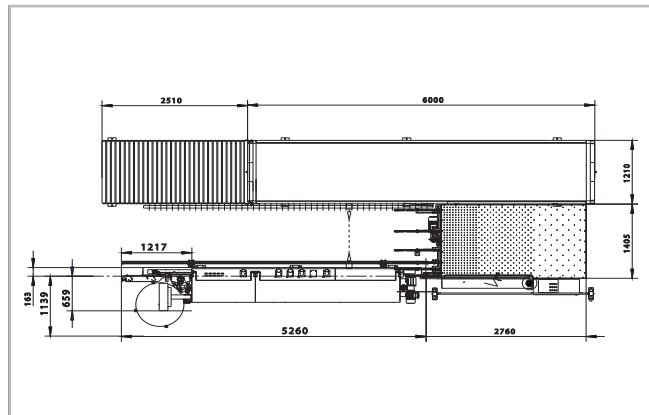

ZHR 340	
Longitudinal throughfeed*:	
Part length	240 - 2,700 mm
Part width	60 - 1,000 mm
Cross throughfeed*:	
Part length	80 - 1,000 mm
Part width	240 - 2,500 mm
Part thickness	8 - 80 mm
Part weight	max. 50 kg
Working height	820 - 980 +/- 30 mm
Feed speed	8 - 30 m/min
Control	Eaton EASY

* Larger parts can be returned or even fed out at 4-sided processing with manual support during crosswise offset and turning.



- **1 CE package**
- **2 Pneumatic air-cushion table for ramp**
- **3 Small-roller gibs to support wide parts**
- **4 Belt cleaning equipment**

other options, see Price list



CE package

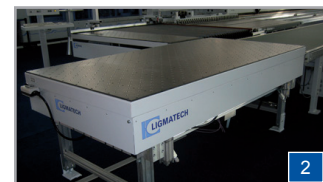

Pneumatic air-cushion table for ramp



Small-roller gibs to support wide parts

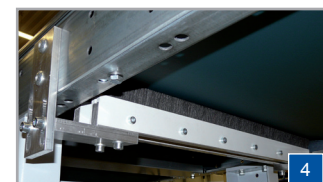

Belt cleaning equipment



lifeline | service

- **eparts** Spare parts ordering online - around-the-clock !

Assembly | Packaging | **Automation**