

**EIGENSCHAFTEN**

- Serienmäßig mit Edelstahlkessel, Rührbesen, Flachrührer und Knethaken.
- 3 Geschwindigkeiten.
- Robuste Maschine.
- Mechanische Übertragung.
- Maschine muss gestoppt werden, wenn die Geschwindigkeit geändert wird.

**CARACTERÍSTICAS**

- Entregada con tina, batidor, pala y gancho.
- 3 velocidades.
- Máquina robusta.
- Transmisión mecánica.
- Hay que parar la máquina para cambiar la velocidad.

**CARATTERISTICHE**

- Vasca, frusta, spatola e spirale in dotazione.
- 3 velocità.
- Costruzione robusta.
- Trasmissione meccanica.
- La macchina deve essere fermata per poter cambiare velocità.



Serienmäßig mit Edelstahlkessel, Rührbesen, Flachrührer und Knethaken.

De serie con tina, batidor, pala removedor y gancho amasador.

Vasca, frusta, spatola e spirale in dotazione.

3 Geschwindigkeiten.

3 velocidades.

3 velocità.

Kesselhebung.

Levantamiento de tina.

Sollevamento vasca.

**SM-100C/200/200C**



Hebel.

Palanca.

Leva.

**SM-500C**



Drehrad.

Manivela.

Manovella.



Robuste Maschine.

Máquina robusta.

Macchina robusta.

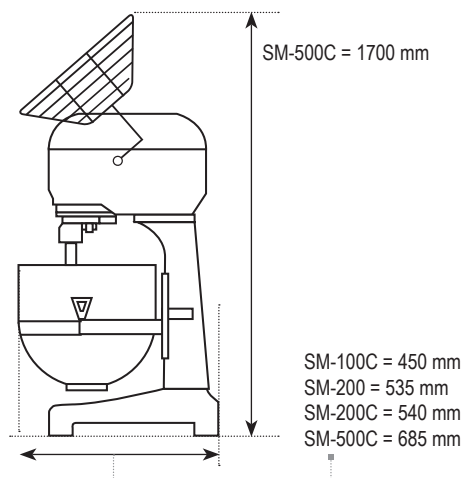
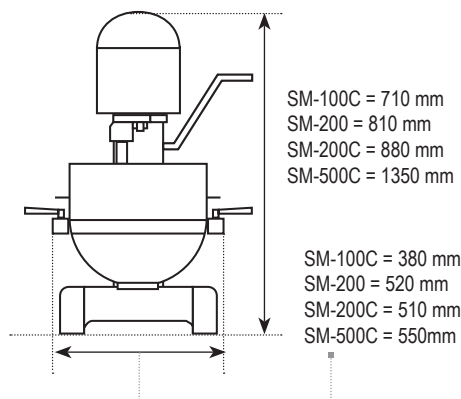
**SEITENANSICHT | PERFIL | VISTA LATERALE**

**VORDERANSICHT | ALZADO | VISTA FRONTALE**

MODEL	SM-100C	SM-200	SM-200C	SM-500C
KAPAZITÄT   CAPACIDAD   CAPACITÀ (L)	10	20 (10 opt.)	20 (10 opt.)	40 (20 opt.)
MOTORLEISTUNG   POTENCIA MOTOR   POTENZA MOTRICE	0,25 kW	0,9 kW	0,9 kW	1,2 kW
U/min bei 50 Hz   Rev./min a 50 Hz   Giri/min a 50 Hz 1./2./3. Geschwindigkeit   1ª/2ª/3ª velocidad   1ª/2ª/3ª velocità	148/307/509	158/293/535	158/293/535	116/208/464
NETTOGEWICHT MASCHINE   PESO NETO MÁQUINA   PESO NETTO MACCHINA	67 kg	110 kg	100 kg	250 kg
SPANNUNG   VOLTAJE   VOLTAGGIO	220V 1Ph 50Hz	220V 1Ph 50Hz	220V 1Ph 50Hz	220/380V 3Ph 50Hz*
OPTION KLEINERER KESSEL   OPCIÓN REDUCCIÓN TINA   OPZIONE VASCA RIDOTTA und Werkzeuge - y utensilios - e attrezzi	✗	✓ 10 L	✓ 10 L	✓ 20 L



SM-100C

SM-200

SM-200C

SM-500C