



SENFENG

HOW TO SELECT YOUR TUBE LASER CUTTING MACHINES



Provide Global Customers with Metal
Forming Automation Solutions

CONTENTS

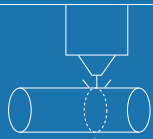

1

About Tube Laser Cutting

Tube Laser Cutting Technology and Business Division

2

Tube Laser Cutting Machines

Specific Models, Competitive Strengths,
Technical Parameters and Specific Configurations

3

Applicable Industries

Practical Usage in Various Industries

4

After-sales Service

Quick-response Service and
Globe-spanning Service Outlets

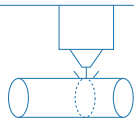

About Tube Laser Cutting

This is a cutting-edge craft using high-energy laser beam to cut tubes. To be specific, it focalizes the laser beam on tube surface, then, makes the most of the interaction between laser photon and tube surface to rapidly melt, vaporize or ignite the tube materials, meanwhile, blows the molten or burning debris away with the help of auxiliary gas, as a result, tube cutting is over.

Tube laser cutting craft is featured by high precision & efficiency, low labor costs, good flexibility & applicability, energy conservation and environment protection. In addition to conventional tubes like round, square and rectangular tube, it can also handle with many special-shaped tubes incl. angle, channel steel, I-beam and H-shaped steel. Now, it is widely popular and of increasingly great importance to tube cutting field.



Business Division

After years of independent R&D and technical innovation, we are now committed to providing global customers with technically mature tube laser cutting solutions. Through persistent probe in some specific tube cutting fields, our family has extended over single-chuck, two-chuck, three-chuck and four-chuck tube cutting machines, ranging from vertical cutting to $\pm 45^\circ$ beveling, from regular to special-shaped tubes, and from semi-automatic to full-automatic operation. Customizing specific machines will also be satisfied by means of our technical supports and after-sales service in all areas.

Our tube laser cutting machines have been highly praised by a sea of workers from power tower, engineering machinery, bodybuilding apparatus, kitchenware and sanitary ware, etc. Their considerable merits below can facilitate the using enterprises to cut down on total costs and consumption, speed up production and eco-friendly development, as well as get more in the future, such as, high cutting precision & efficiency, sightly cutting surface and mass production.

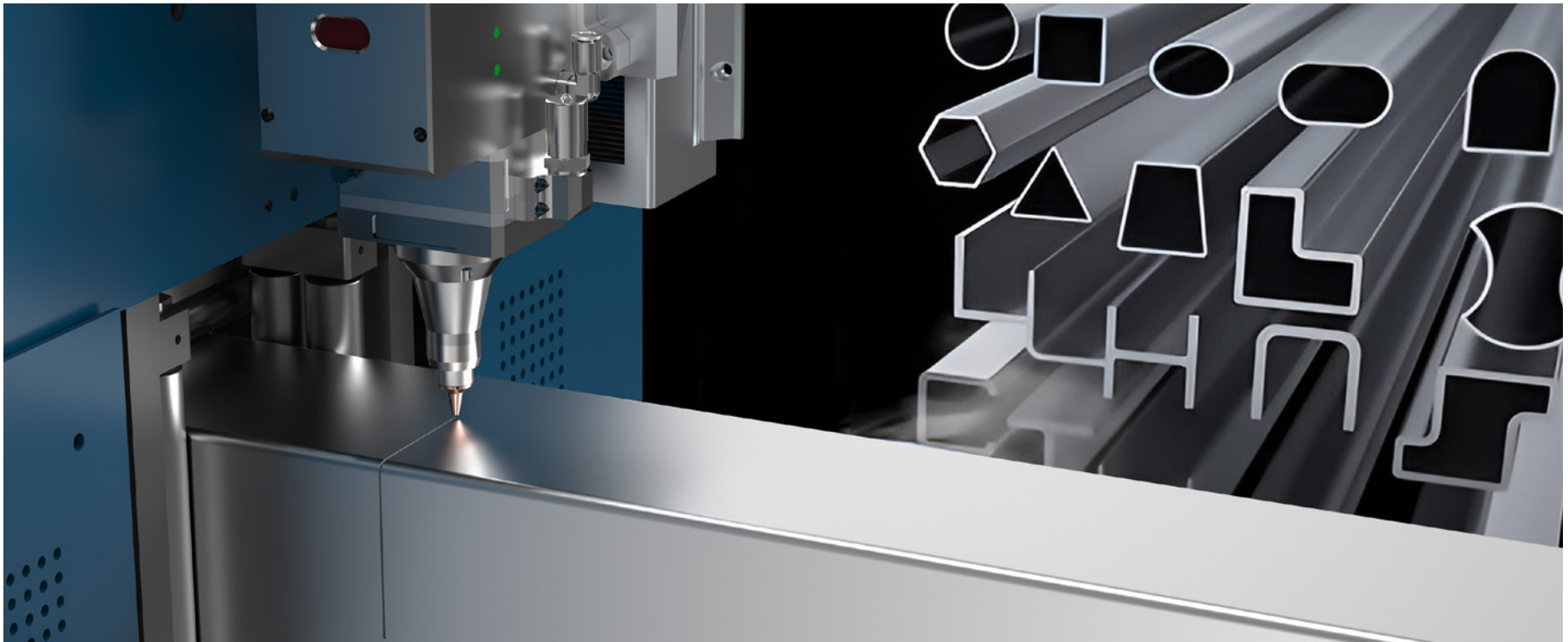

S1 Series Two-chuck Tube Laser Cutting Machine (Horizontal)

SF6012S1 Clamping range of chucks: 15-120mm

SF6016S1 Clamping range of chucks: 15-170mm

SF6024S1 Clamping range of chucks: 20-240mm



Technical Parameters

Model	SF6012S1	SF6016S1	SF6024S1
Laser power	1500-3000W	1500-3000W	1500-6000W
Max length of tube	6500mm	6500mm	6500mm
Clamping range of chucks	Φ15-120mm, □15*15-120*120mm	Φ15-170mm, □15*15-170*170mm	Φ20-240mm, □20*20-240*240mm
Max load of chucks	≤120kg	≤150kg	≤260kg
Max rotating speed of chucks	80-180r/min	80-180r/min	100r/min
Max no-load speed	80-150m/min	80-150m/min	100m/min
Max acceleration	0.8-1.5G	0.8-1.5G	1G
Loading device (optional)	Semi-/fully-automatic loading device	Semi-/fully-automatic loading device	Semi-/fully-automatic loading device
Unloading device (optional)	2m (or 3m/4m as required)	2m (or 3m/4m as required)	2m (or 3m/4m as required)
Type of tube supports	Vari-pitch support/Follow-up support	Vari-pitch support/Follow-up support	Vari-pitch support/Follow-up support

S2 Series Two-chuck Tube Laser Cutting Machine (Side-attached)

SF6012S2 Clamping range of chucks: 15-120mm

SF6016S2 Clamping range of chucks: 15-170mm

SF6024S2 Clamping range of chucks: 20-240mm



Technical Parameters

Model	SF6012S2	SF6016S2	SF6024S2
Laser power	3000W	3000W	3000-6000W
Max length of tube	6500mm	6500mm	6500mm
Clamping range of chucks	Φ15-120mm, □15*15-120*120mm	Φ15-170mm, □15*15-170*170mm	Φ20-240mm, □20*20-240*240mm
Max load of chucks	≤120kg	≤150kg	≤260kg
Max rotating speed of chucks	240r/min	200r/min	90r/min
Max no-load speed	150m/min	150m/min	150m/min
Max acceleration	1.5G	1.5G	1G
Loading device	Fully-automatic loading device (or semi-automatic type as optional)		Semi-automatic loading device
Unloading device (optional)	2m (or 3m/4m as required)	2m (or 3m/4m as required)	2m (or 3m/4m as required)
Type of tube supports	Vari-pitch support/Follow-up support	Vari-pitch support/Follow-up support	Vari-pitch support/Follow-up support

* Machine appearance, function description and technical parameters on this page are derived from SENFENG's Technical R&D Center based on our self-developed machines. For reference only, in kind prevail!

PLUS Series Two-chuck Tube Laser Cutting Machine

SF6012PLUS Clamping range of chucks : 15-120mm

SF6016PLUS Clamping range of chucks : 15-170mm

SF6024PLUS Clamping range of chucks : 20-230mm

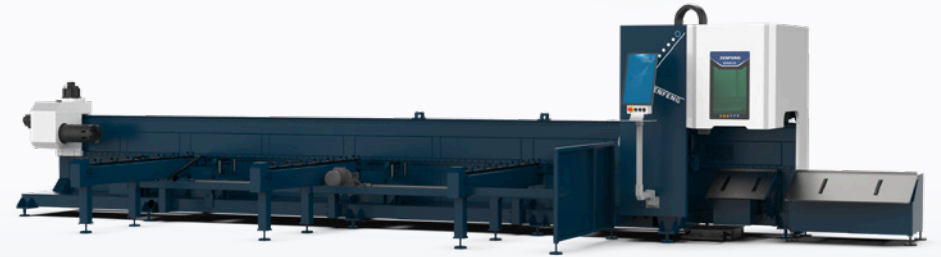

Technical Parameters

Model	SF6012PLUS	SF6016PLUS	SF6024PLUS
Laser power	1500-3000W	1500-3000W	3000-6000W
Max length of tube	6500mm	6500mm	6500mm
Clamping range of chucks	Φ15-120mm, □15*15-120*120mm	Φ15-170mm, □15*15-170*170mm	Φ20-230mm, □20*20-230*230mm
Max load of chucks	120kg	160kg	260kg
Max acceleration	1.5G	1.5G	1.0G
Max no-load speed	150m/min	150m/min	100m/min
Max rotating speed of chucks	240r/min	200r/min	100r/min
Loading device	Semi-/fully-automatic loading device	Semi-/fully-automatic loading device	Semi-automatic loading device
Applicable industry	Baby stroller and cot, bodybuilding apparatus, railings & handrails, office desk and chair, furniture, kitchenware and sanitary ware, etc.		

G PLUS Series Two-chuck Beveling Tube Laser Cutting Machine

SF6012G PLUS

Clamping range of chucks: 15-120mm

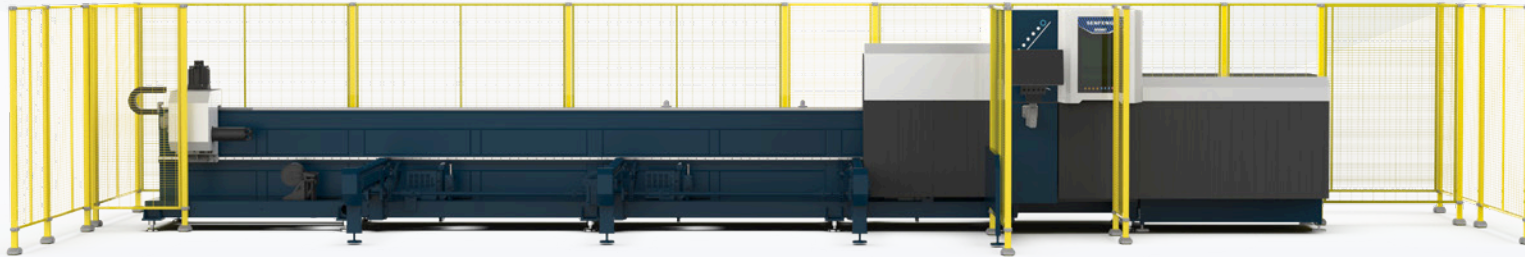

Technical Parameters

Model	SF6012G PLUS
Laser power	3000W
Max length of tube	6500mm
Clamping range of chucks	Φ15-120mm, □15*15-120*120mm
Max load of chucks	≤120kg
Max rotating speed of chucks	240r/min
Max no-load speed	150m/min
Max acceleration	1.5G
Loading device	Fully-automatic loading device (or semi-automatic type as optional)
Unloading device (optional)	2m (or 3m as required)

T Series Two-chuck Tube Laser Cutting Machine

SF6012T

Clamping range of chucks: 15-120mm

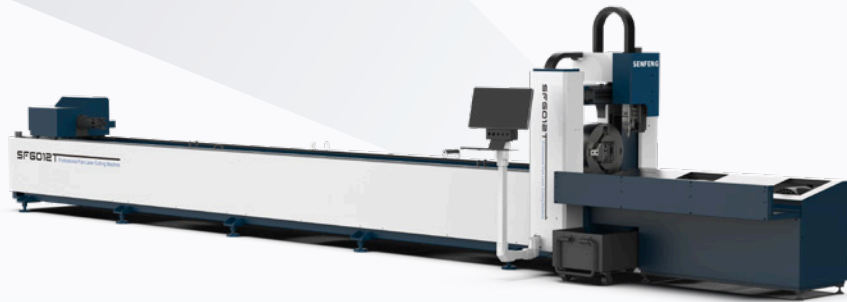

SF6016T

Clamping range of chucks: 15-170mm

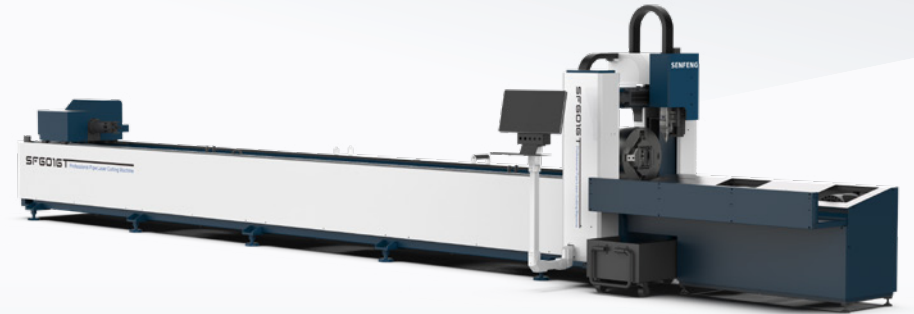

Technical Parameters

Model	SF6012T	SF6016T
Laser power	1500-3000W	1500-3000W
Max length of tube	6000mm	6000mm
Clamping range of chucks	Φ15-120mm, □15*15-120*120mm	Φ15-170mm, □15*15-170*170mm
Max load of chucks	120kg	160kg
Max acceleration	1.5G	1.2G
Max no-load speed	150m/min	110m/min
Max rotating speed of chucks	180r/min	140r/min
Loading device (optional)	Semi-/fully-automatic loading device	Semi-/fully-automatic loading device
Unloading device	2m	2m
Type of tube supports	Vari-pitch support/Follow-up support	Vari-pitch support/Follow-up support
Applicable industry	Display props, bodybuilding apparatus, medical instrument, metal furniture, railing production, office furniture, door & window manufacturing, etc.	

T Series Two-chuck Tube Laser Cutting Machine

SF6024T

Clamping range of chucks: 20-230mm

SF6035T

Clamping range of chucks: 20-360mm



Technical Parameters

Model	SF6024T	SF6035T
Laser power	1500-6000W	1500-6000W
Max length of tube	6000mm	6000mm
Clamping range of chucks	Φ20-230mm, □20*20-230*230mm	Φ20-360mm, □20*20-360*360mm
Max load of chucks	260kg	500kg
Max acceleration	1.0G	0.6G
Max no-load speed	100m/min	60m/min
Max rotating speed of chucks	100r/min	60r/min
Loading device (optional)	Semi-/fully-automatic loading device	Semi-/fully-automatic loading device
Unloading device	2m	2m
Type of tube supports	Vari-pitch support/Follow-up support	Vari-pitch support/Follow-up support
Applicable industry	Metalworking, bodybuilding apparatus, goods shelf, bicycle, vehicle frame, etc.	

GT Series Two-chuck Tube Laser Cutting Machine (Beveling)

SF6024GT

Clamping range of chucks: 20-230mm

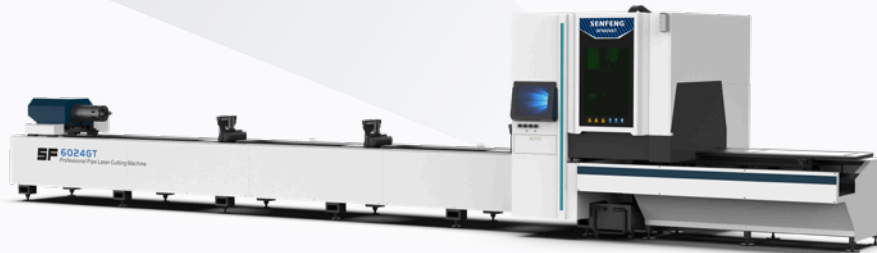

SF6035GT

Clamping range of chucks: 20-360mm



Technical Parameters

Model	SF6024GT	SF6035GT
Laser power	3000-6000W	3000-6000W
Max length of tube	6000mm	6000mm
Clamping range of chucks	Φ20-230mm, □20*20-230*230mm	Φ20-360mm, □20*20-360*360mm
Max load of chucks	260kg	500kg
Max acceleration	1.0G	0.6G
Max no-load speed	100m/min	60m/min
Max rotating speed of chucks	100r/min	60r/min
Tube support device	Follow-up support	Follow-up support
Loading device (optional)	Semi-/fully-automatic loading device	Semi-/fully-automatic loading device
Unloading device	2m	2m
Applicable industry	Metalworking, bodybuilding apparatus, goods shelf, bicycle, vehicle frame, etc.	

NT Series Three-chuck Tube Laser Cutting Machine (Horizontal)

SF6024NT

Clamping range of chucks: 20-230mm



SF6035NT

Clamping range of chucks: 20-360mm



Technical Parameters

Model	SF6024NT	SF6035NT
Laser power	3000-6000W	3000-6000W
Max length of tube	6500mm	6500mm
Clamping range of chucks	Φ20-230mm, □20*20-230*230mm	Φ20-360mm, □20*20-360*360mm
Max load of chucks	260kg	500kg
Max acceleration	0.8G	0.6G
Max no-load speed	75m/min	60m/min
Max rotating speed of chucks	100r/min	60r/min
Tube support device	Follow-up support	Follow-up support
Loading device (optional)	Semi-/fully-automatic loading device	Semi-/fully-automatic loading device
Unloading device	3m (standard), 6m (optional)	3m (standard), 6m (optional)
Beveling	Optional	Optional
Applicable industry	Engineering machinery, metalworking, bridge & tunnel, vehicle frame, harbor machinery, steel structure, etc.	

NT Series Three-chuck Tube Laser Cutting Machine (Horizontal)

SF9024NT

Clamping range of chucks: 20-230mm



SF9035NT

Clamping range of chucks: 20-360mm



Technical Parameters

Model	SF9024NT	SF9035NT
Laser power	3000-6000W	3000-6000W
Max length of tube	9000mm	9000mm
Clamping range of chucks	Φ20-230mm, □20*20-230*230mm	Φ20-360mm, □20*20-360*360mm
Max load of chucks	260kg	600kg
Max acceleration	0.8G	0.6G
Max no-load speed	75m/min	60m/min
Max rotating speed of chucks	100r/min	60r/min
Tube support device	Follow-up support	Follow-up support
Loading device (optional)	Semi-/fully-automatic loading device	Semi-/fully-automatic loading device
Unloading device	3m (standard), 6m/9m (optional)	3m (standard), 6m/9m (optional)
Beveling	Optional	Optional
Applicable industry	Engineering machinery, metalworking, bridge & tunnel, vehicle frame, harbor machinery, steel structure, etc.	

NT Series Three-chuck Tube Laser Cutting Machine (Horizontal)

SF12024NT

Clamping range of chucks: 50–230mm

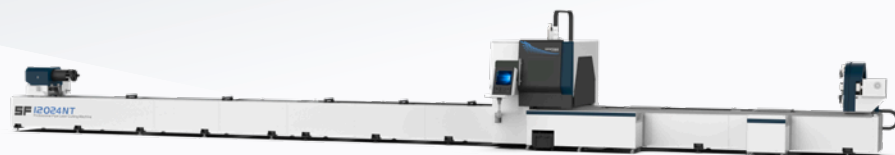

SF12035NT

Clamping range of chucks: 50–360mm

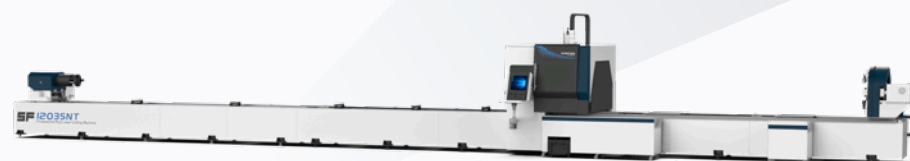

Technical Parameters

Model	SF12024NT	SF12035NT
Laser power	3000–6000W	3000–6000W
Max length of tube	12000mm	12000mm
Clamping range of chucks	Φ50–230mm, □50*50–230*230mm	Φ50–360mm, □50*50–360*360mm
Max load of chucks	≤260kg	≤700kg
Max rotating speed of chucks	100r/min	60r/min
Max no-load speed	75m/min	60m/min
Max acceleration	0.8G	0.6G
Loading device (optional)	12m (semi-automatic)	12m (semi-/fully-automatic)
Unloading device	3m (or 6m/9m/12m as required)	3m (or 6m/9m/12m as required)

S3 Series Three-chuck Tube Laser Cutting Machine (Side-attached)

SF6024S3 Clamping range of chucks: 20-240mm

SF12028S3 Clamping range of chucks: 20-280mm

SF12035S3 Clamping range of chucks: 50-360mm

SF12050S3 Clamping range of chucks: 50-500mm

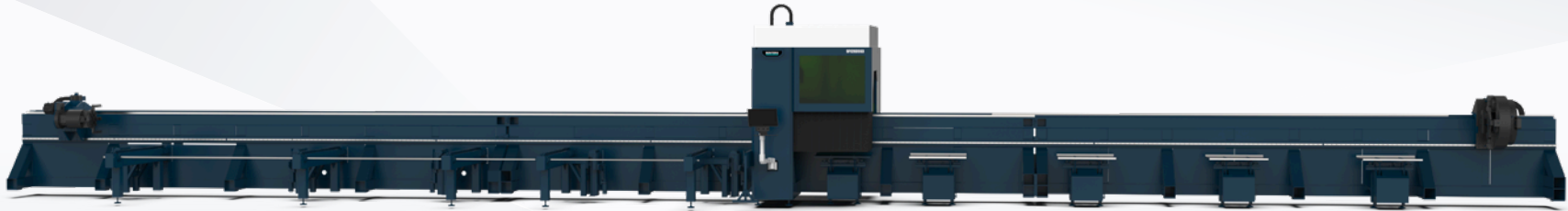

Technical Parameters

Model	SF6024S3	SF12028S3	SF12035S3	SF12050S3
Laser power	6000-12000W	6000-12000W	6000-20000W	6000-20000W
Max length of tube	6500mm	12000mm	12000mm	12000mm
Clamping range of chucks	Φ20-240mm, □20*20-240*240mm	Φ20-280mm, □20*20-280*280mm	Φ50-360mm, □50*50-360*360mm	Φ50-500mm, □50*50-500*500mm
Max load of chucks	≤300kg	≤600kg	≤1000kg	≤2000kg
Max rotating speed of chucks	60r/min	60r/min	60r/min	50r/min
Max no-load speed	60m/min	60m/min	60m/min	50m/min
Max acceleration	0.6G	0.6G	0.6G	0.4G
Beveling (optional)	±45°	±45°	±45°	±45°
Loading device	Semi-automatic loading system	12m automatic loading system	12m automatic loading system	12m semi-automatic loading system
Unloading device	2m (or 3m/4m as required)	6m (or 9m/12m as required)	6m (or 9m/12m as required)	6m (or 9m/12m as required)

* Machine appearance, function description and technical parameters on this page are derived from SENFENG's Technical R&D Center based on our self-developed machines. For reference only, in kind prevail!

ST Series Three-chuck Tube Laser Cutting Machine (Side-attached)

SF9035ST Clamping range of chucks: 50-360mm

SF12035ST Clamping range of chucks: 50-360mm

SF12035PLUS Clamping range of chucks: 50-360mm



Technical Parameters

Model	SF9035ST	SF12035ST	SF12035 PLUS
Laser power	6000-20000W	6000-20000W	6000-20000W
Max length of tube	9000mm	12000mm	12000mm
Clamping range of chucks	Φ50-360mm, □50*50-360*360mm	Φ50-360mm, □50*50-360*360mm	Φ50-360mm, □50*50-360*360mm
Max load of chucks	1000kg	1000kg	1200kg
Max acceleration	0.6G	0.6G	0.6G
Max no-load speed	60m/min	60m/min	60m/min
Max rotating speed of chucks	60r/min	60r/min	60r/min
Tube support device	Follow-up support	Follow-up support	Follow-up support
Loading device	Semi-automatic loading device	Semi-automatic loading device	Semi-automatic loading device
Unloading device	6m (standard), 9m (optional)	6m (standard), 9m/12m (optional)	6m (standard), 9m/12m (optional)
Beveling	Optional	Optional	Optional
Applicable industry	Engineering machinery, heavy machinery, building machinery, steel structure, bridge formwork, etc.		

* Machine appearance, function description and technical parameters on this page are derived from SENFENG's Technical R&D Center based on our self-developed machines. For reference only, in kind prevail!

ST Series Three-chuck Tube Laser Cutting Machine (Side-attached)

SF12050ST Clamping range of chucks: 50-500mm

SF12056ST Clamping range of chucks: 50-560mm

SF12065ST Clamping range of chucks: 50-650mm

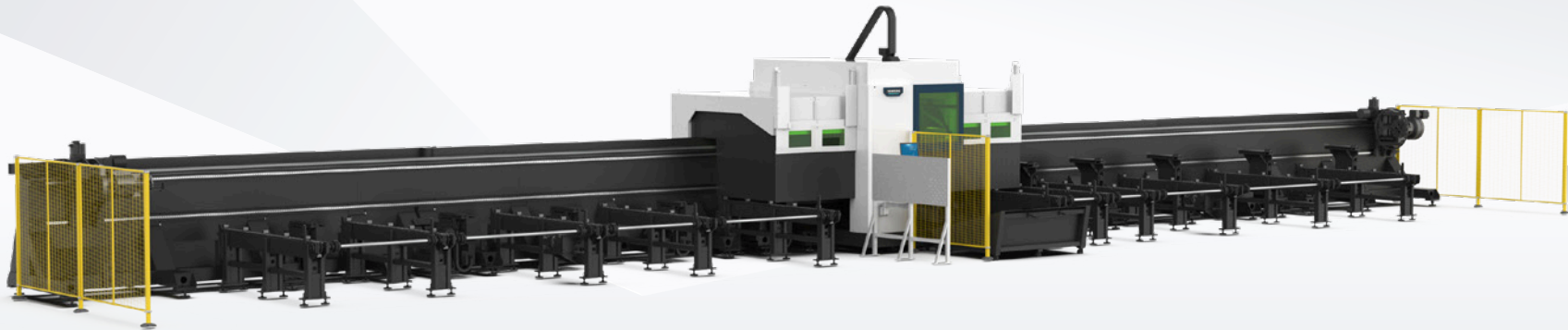

Technical Parameters

	SF12050ST	SF12056ST	SF12065ST
Model	SF12050ST	SF12056ST	SF12065ST
Laser power	6000-20000W	6000-20000W	6000-20000W
Max length of tube	12000mm	12000mm	12000mm
Clamping range of chucks	Φ50-500mm, □50*50-500*500mm	Φ50-560mm, □50*50-560*560mm	Φ50-650mm, □50*50-650*650mm
Max load of chucks	≤2000kg	≤1800kg	≤2500kg
Max rotating speed of chucks	40r/min	30r/min	30r/min
Max no-load speed	40m/min	30m/min	30m/min
Max acceleration	0.3G	0.3G	0.3G
Beveling (optional)	±45°	±45°	±45°
Loading device	12m (automatic)	12m (automatic)	12m (automatic)
Unloading device	6m (or 9m/12m as optional)	6m (or 9m/12m as optional)	6m (or 9m/12m as optional)

* Machine appearance, function description and technical parameters on this page are derived from SENFENG's Technical R&D Center based on our self-developed machines. For reference only, in kind prevail!

HT Series Four-chuck Tube Laser Cutting Machine (Side-attached)

SF12050HT Clamping range of chucks: 50-500mm

SF12056HT Clamping range of chucks: 50-560mm

SF12065HT Clamping range of chucks: 50-650mm

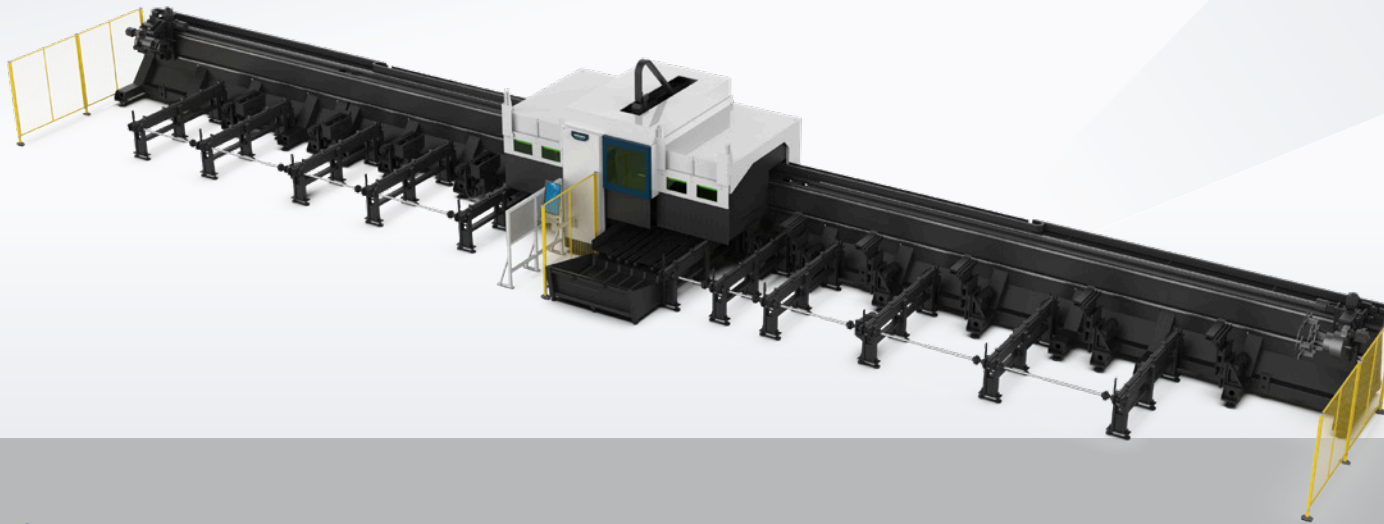

Technical Parameters

Model	SF12050HT	SF12056HT	SF12065HT
Laser power	6000-20000W	6000-20000W	6000-20000W
Max length of tube	12000mm	12000mm	12000mm
Clamping range of chucks	Φ50-500mm, □50*50-500*500mm	Φ50-560mm, □50*50-560*560mm	Φ50-650mm, □50*50-650*650mm
Max load of chucks	≤2000kg	≤1800kg	≤2500kg
Max rotating speed of chucks	40r/min	30r/min	30r/min
Max no-load speed	40m/min	30m/min	30m/min
Max acceleration	0.3G	0.3G	0.3G
Beveling (optional)	±45°	±45°	±45°
Loading device	12m (automatic)	12m (automatic)	12m (automatic)
Unloading device	6m (or 9m/12m as optional)	6m (or 9m/12m as optional)	6m (or 9m/12m as optional)

Large H Beam Laser Cutting Machine

SF1500CH

Working area: 28000*3000mm

SF1412CH

Working area: 14000*3000mm



Technical Parameters

Model	SF1500CH	SF1412CH
Laser power	12000-40000W	12000-40000W
Max length of workpiece	12000mm*2	12000mm
H beam size	Max width of H beam (web): 1200mm Max height of H beam (flange slab): 500mm Max working area of flat sheet: 28000*3000mm (max width if beveling: 2500mm)	Max width of H beam (web): 1200mm Max height of H beam (flange slab): 500mm Max working area of flat sheet: 14000*3000mm (max width if beveling: 2500mm)
Thickness of H beam	≤40mm	≤50mm
Max acceleration	0.5G	0.5G
Max no-load speed	60m/min	50m/min
Applicable industry	Steel structure, building bridge & tunnel, harbor machinery, etc.	Steel structure, building bridge & tunnel, harbor machinery, etc.

* Machine appearance, function description and technical parameters on this page are derived from SENFENG's Technical R&D Center based on our self-developed machines. For reference only, in kind prevail!

Automated Tube Storage & Cutting Solution

By centrally managing tubes with an automated storage system, a single solution serves two laser tube cutting machines, enabling automated storage, intelligent scheduling, and stable loading. This reduces manual intervention, improves machine utilization, and supports efficient, continuous tube cutting operations.

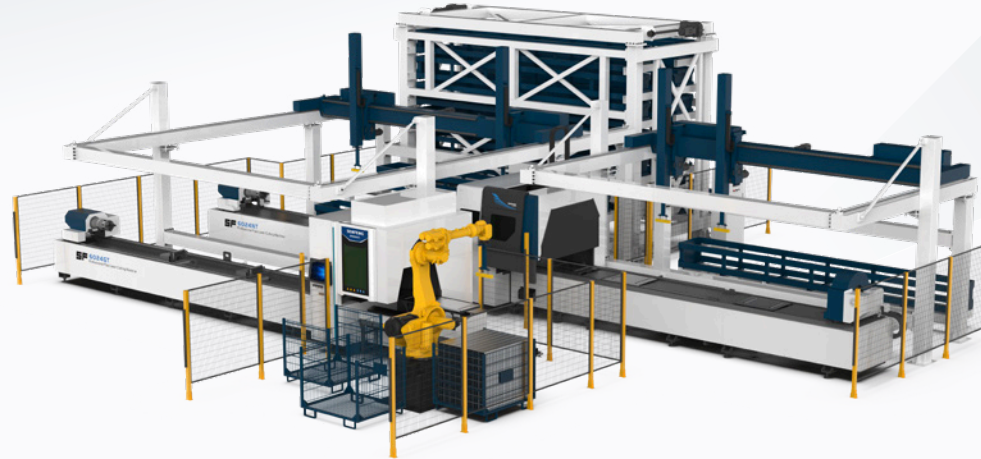

Fish-belly Beam and Side Beam Laser Cutting Workstation

It is composed of profile steel laser cutting machine, magnetic loading & unloading system and exchange worktables, or may equip with safety fence, light curtain, door and other accessories to cut 15500mm long, 40mm thick profile steel at the laser power of 20kW.

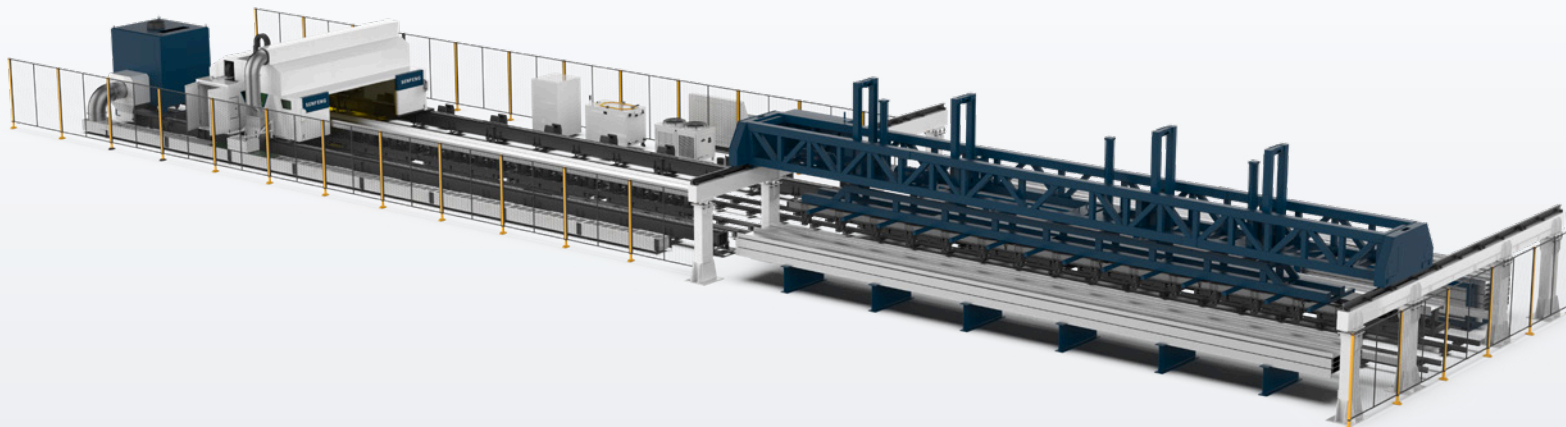

Custom-made Automation Solutions

SAL

Semi-automatic Chained Loading Device

SAL1-6



- Load 6m long tube
- Work with SF6035T SF6035GT SF6035NT

SAL2-9



- Load 9m long tube
- Work with SF9035T SF9035GT SF9035NT

SAL3-12



- Load 12m long tube
- Work with SF12035NT

XAL

Semi-automatic Sloped Loading Device

XAL120B-6



- Load 6m long tube
- Work with SF6016T SF6020T SF6024T

SFH

Semi-automatic Sloped Loading Device

- Work with SF6024T SF6024GT SF6024NT SF9024T SF9024NT SF12024T SF12024NT



SFB

Fully-automatic Simply-designed Loading Device

SFB250-6



- Load 6m long tube
- Work with
SF6016T SF6020T SF6024T SF6024GT
SF6035GT SF6024NT SF6035NT

SFB350-9



- Load 9m long tube
- Work with
SF9016T SF9020T SF9024T SF9024GT
SF9035GT SF9024NT SF9035NT

SFB550-12



- Load 12m long tube
- Work with
SF12024T SF12024NT SF12035NT

SFQ

Fully-automatic Loading Device

SF250Q-6



- Load 6m long tube
- Work with
SF6016T SF6020T SF6024T SF6024GT
SF6035GT SF6024NT SF6035NT

SF350Q-9

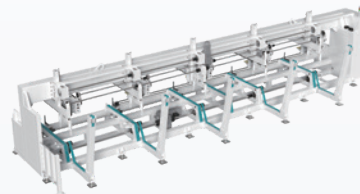

- Load 9m long tube
- Work with
SF9016T SF9020T SF9024T SF9024GT
SF9035GT SF9024NT SF9035NT

SF400Q-12



- Load 12m long tube
- Work with
SF12024T SF12024NT SF12035NT

Showcase of Tube Cutting Crafts

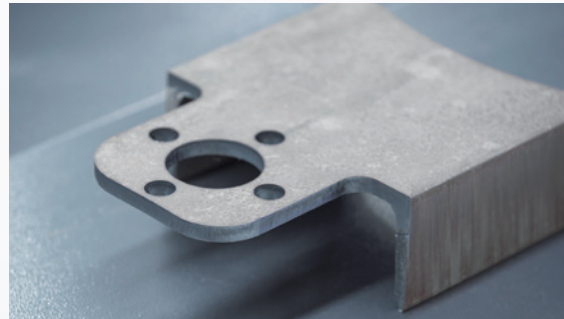
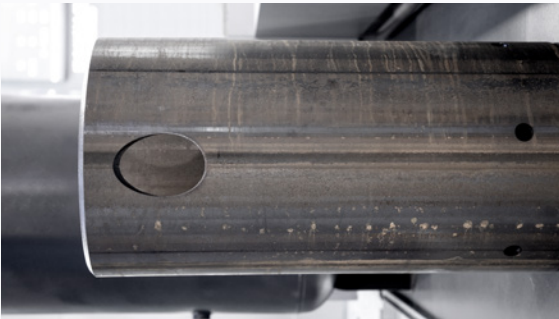
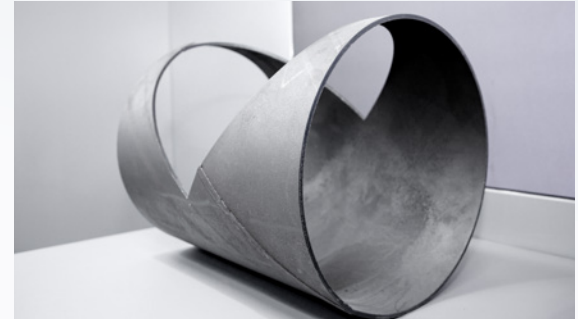

Applicable Industry



Steel structure



Railing production



Petroleum pipeline



Engineering machinery



Bridge formwork



Medical instrument



Bodybuilding apparatus

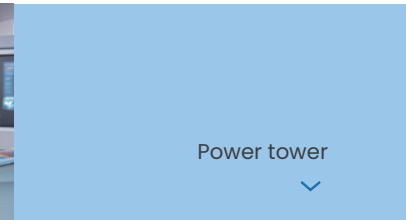

Power tower



Quick-response Service



High Efficiency

Answer your repair calls for 24*7*365 days

Technical engineers can diagnose your machine within 10min, make repair plans within 1h and dispatch to your location within 1 workday after receiving your request for repair



Craftsmanship Spirit

Provide custom-made solutions and make well-targeted plans as the case may be

Engineer certifications: Our all engineers take appointment with certificate after strict training

Train how to fix your FAQ: Collect FAQ and ask the certified engineers to train relevant customers

Online one-to-one guidance: Senior engineers guide customers to get problems solved through phone, video or other online means

One time is enough: Commission the machine and settle similar matters only once



For Your Peace of Mind

Pre-arrival service: Train in technical theory, actual operation and troubleshooting at great length

Regular service: Reminder of maintenance, door-to-door and sales promotion service

Value-added service: Software & hardware upgrade, finance leasing and further extension of warranty period



Start VR Tour

Jinan Senfeng Laser Technology Co., Ltd.

📍 No. 1777 Kejia Road, High-tech Zone, Jinan City, Shandong Province, PRC

☎ +86 132 1054 6543 ✉ senfeng@sfcnclaser.com

🌐 www.senfenglaser.com

Note: The pictures and parameters in the album are for reference only, and the actual product shall prevail. Printed in Mar. 2026.