

## 540 CALIBER A-CNC 41x1,3

 mm  
550

 mm  
550x520

 mm  
550x460

  
3x400V 50 Hz

  
5,5

  
20-120

  
6200x41x1,3

  
3700

Lmin  
3600

Lmax  
4300

B  
2030

Hmin  
2420

Hmax  
2550

V  
800



STANDARD    OPTION

- 540-F
- 540-DRIVE
- 540-C-WRS
- 540-NPH-2
- 540-BCA-7
- 540-IRP
- 540-OCF
- 540-C-CMU1
- 540 - BSF
- 540-HPV
- 540-C-ECK
- LED
- 540-C-RTS-A

- MINILUBE 41
- LASER LINE
- 540-HM-DRIVE
- 540-C-OCS
- 540-C-ATB
- 540-C-HP-A

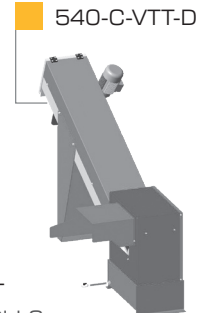
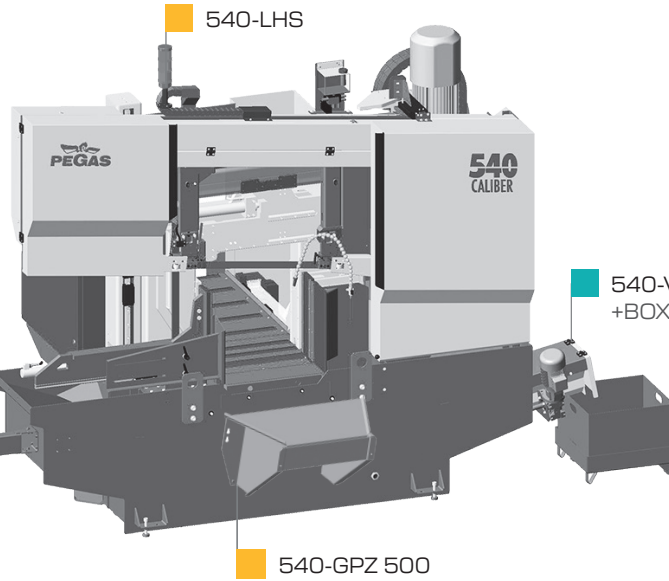
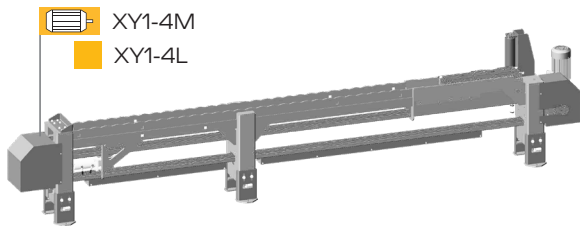
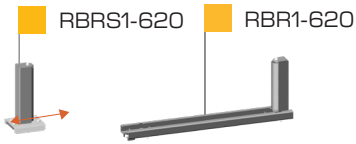
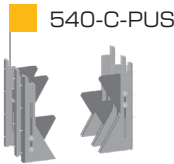
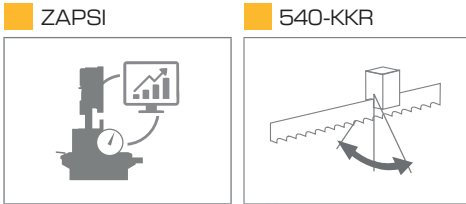
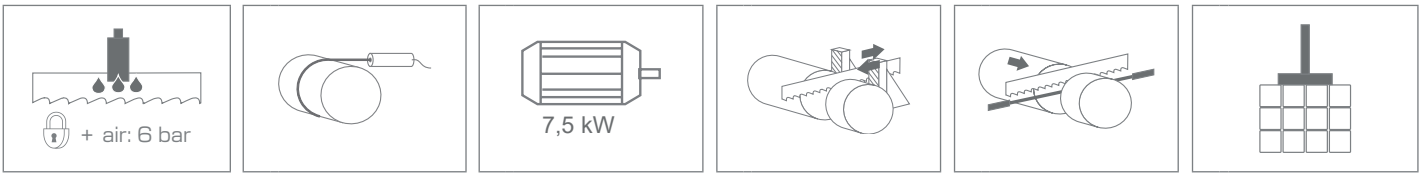

540-VTT  
+BOX TRI-L2



## 540 CALIBER A-CNC

- výrobce si vyhrazuje právo provádět změny  
technických údajů, technické údaje odpovídají 1.1.2025  
/ producer has the right to make changes of technical data,  
technical data are valid on 1.1.2025

- pila na fotografii není vždy v základním provedení,  
uvedené rozměry odpovídají stroji v základním provedení  
/ the machine in the picture is not always in the basic version,  
mentioned diameters are for machine in basic version

\* doporučená hodnota. Při překročení doporučeného  
maximálního průměru není možné garantovat výkon  
pilového pásu!  
/ recommended value. The blade performance cannot  
be guaranteed  
when the recommended diameter is exceeded!

☒ - řezání svazků bez horního přitlaku  
/ cutting of the bundle without top clamping

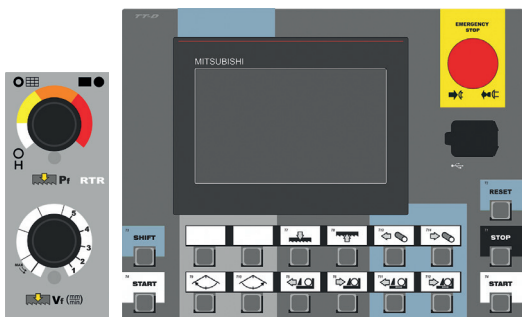

RTR CONTROL PANEL: MITSUBISHI (A-CNC)



PEGAS - GONDA s.r.o.  
Čs.armády 322, 684 01 Slavkov u Brna,  
CZECH REPUBLIC

www.pegas-gonda.cz  
00420-544 221 125 (126) | pegas@gonda.cz