

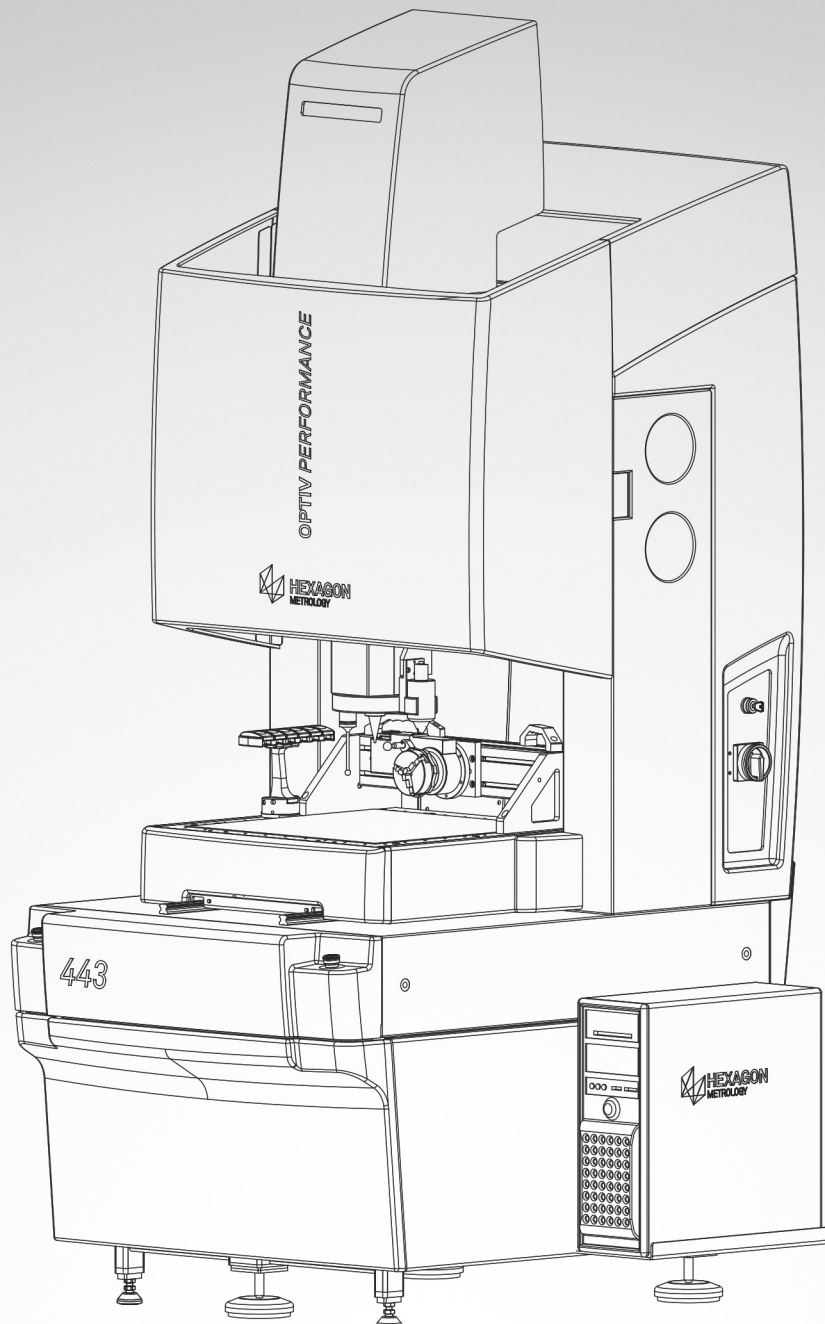

# OPTIV PERFORMANCE 443

Version February 2015



**Product description** The Optiv Performance 443 combines optical and tactile measurement in one system. The system supports multi-sensor measurements using the Vision-Sensor, the touch-trigger and scanning probe, the TTL laser (Through-The-Lens) as well as the innovative Chromatic White Light Sensor (CWS). Measurement software is PC-DMIS Vision.

- Fields of application**
- Shop floor and inspection room
  - Versatile geometry measurements and GD&T analysis

- Design**
- Design principle:
    - » Low-vibration granite construction with a fixed bridge and a moving table
    - » Integrated subframe
  - Guides:
    - » Mechanical linear guides on all axes
  - Drives:
    - » DC servo motors, power transmission via backlash free circulating ball screws
  - Length measuring system:
    - » Incremental optoelectronic length measuring system
  - Resolution of the scales:
    - » 10 nm

**Measuring range**  
(X x Y x Z)

	Measuring range Optiv Performance 443		
	Vision-Sensor	HP-S-X1	Mutual measuring range <sup>(1)</sup>
X	400 mm (15.75 in.)	360 mm (14.17 in.)	335 mm (13.19 in.)
Y	400 mm (15.75 in.)	400 mm (15.75 in.)	400 mm (15.75 in.)
Z	300 mm (11.81 in.)	300 mm (11.81 in.)	300 mm (11.81 in.)

<sup>(1)</sup> Vision-Sensor <—>  
HP-S-X1 (X offset = 65 mm)

- Loading capacity**
- Load-bearing capacity of the table up to 30 kg

- Dimensions in mm and weights in kg**
- Dimensions see machine layout on page 7
  - Machine weight 1100 kg

**Measuring accuracy <sup>(2)</sup>**

<sup>(2)</sup> The conditions of acceptance of Hexagon Metrology Vision apply.

<sup>(3)</sup> E is valid for a stylus of Ø 5 mm, L = 50 mm.

<sup>(4)</sup> P and THP are valid for a stylus of Ø 5 mm, L = 20 mm.

L = measurement length in mm

At 20°C, according to ISO 10360-7, with Vision-Sensor, at highest zoom magnification, standard measuring plane <sup>(2)</sup>

X, Y measuring accuracy $E_x, E_y = (1.5 + L/400) \mu\text{m}$
XY measuring accuracy $E_{xy} = (1.9 + L/250) \mu\text{m}$
Z measuring accuracy $E_z = (1.9 + L/200) \mu\text{m}$

At 20°C, according to ISO 10360-2 / -4, with the HP-S-X1C probing system <sup>(2)</sup>

Volumetric length measuring error <sup>(3)</sup> $MPE_E = (1.9 + L/250) \mu\text{m}$
Volumetric probing error <sup>(4)</sup> $MPE_P = 1.9 \mu\text{m}$
Volumetric scanning probing error <sup>(4)</sup> $MPE_{THP} = 2.9 \mu\text{m} (t = 78 \text{ sec})$
A set of 5 gauges has to be measured 3 times with one probing at each end, in 7 different directions in space. All measuring results must be within "E".
A precision sphere has to be measured with 25 probeings. P is the range of all radii. $P = R_{\text{max}} - R_{\text{min}} = \text{sphere form.}$
A precision sphere has to be scanned with 4 defined lines. THP is the range of all radii. $THP = R_{\text{max}} - R_{\text{min}} = \text{sphere form, scanning.}$

- Airborne noise emissions
  - The A-weighted emission sound pressure level at operator’s position is less than 70 db(A).
  
- Environmental requirements
  - Limits of permissible floor vibration  $< 5 \times 10^{-3} \text{ m/s}^2$  corresponds to an amplitude of  $< 5 \text{ }\mu\text{m}$  at 5 Hz
  - Air humidity 40 % - 70 % RL, non-condensing
  - Environmental temperature  $20 \text{ }^\circ\text{C} \pm 2 \text{ }^\circ\text{C}$
  - Permissible temperature gradient  $0.8 \text{ }^\circ\text{C/h}$ ,  $1.0 \text{ }^\circ\text{C/d}$ ,  $0.6 \text{ }^\circ\text{C/m}$
  
- Throughput
  - Max. traversing speed
    - » 150 mm/s (per axis), 250 mm/s (vector)
  
- Supply data
  - Input voltage power supply  $115\text{-}230 \text{ V} \pm 10\%$
  - Frequency  $50/60 \text{ Hz} \pm 5\%$
  - Power consumption 1000 VA
  - Air supply (optional vibration damping system):
    - » Air pressure connection with 1/2-inch quick-connect coupling
    - » Air pressure at least 400000 pascal (Pa), max. 600000 pascal (Pa)
    - » Air consumption approx. 5-20 NI/min (dynamic), 0.5-1 NI/min (static)
    - » Pre-cleaned air according to ISO 8573-1 class 1

Vision-Sensor

Technical description

- Sensor for non-contact measurement of smallest and closely toleranced features
  - » High resolution CCD camera, for interference-free, low noise image reproduction
  - » Maximum optical precision due to low distortion optics
    - » Motorised CNC zoom
    - » Fixed optics
    - » Dual Camera optics
  - » Powerful image processing
    - » Fast, precision video autofocus
    - » Automatic feature detection, geometry and bad pixel video filters
    - » Contour scanning mode:  
Sophisticated set of user-selectable algorithms to setup edge detection, intelligent, automatic selection of the most suitable setting for the measurement
    - » Best fit routines
    - » AutoTune:  
Transferability of measuring programs between machines of the same type
    - » MultiCapture:  
MultiCapture allows all 2D features within a field of view to be captured simultaneously, regardless of the feature type. Inspection speeds can be increased by 35 % or more, depending on the feature size and density. The capture sequence for groups of features using MultiCapture is also automatically optimized, creating the most efficient possible path with the fewest number of stage movements.

Illumination for Vision-Sensor

- Coaxial LED top light
- LED back light
- 12-segment LED ring light (white LEDs)
  - » 3 rings with 3 different angles of incidence (27 °, 35 °, 45 °) and 4 segments each

CNC zoom

- 10x motorised zoom, for a continuous adjustment of field of view and resolution
- High resolution 1/2-inch CCD camera (H 752 x V 582 pixels)

Magnification variants of the 10x CNC zoom on a 20 in. monitor					
Lens	Magnification	Working distance (mm)	Max. workpiece height (mm)	Max. field of view (mm)	Min. field of view (mm)
Standard	0.65x to 6.5x	86	0 to 300	10.2 x 7.7	1.0 x 0.8

Fixed optics with changeable lenses (optional)

- Fixed focal length, telecentric precision optics
- CCD camera 1/2"
  - » H 752 x V 582 pixel
- Available lenses 1x, 3x, 5x, 10x

Magnification variants of the fixed optics				
Optical magnification of the lens	Working distance (mm)	Pixel size (µm/pixel)	Field of view H x V (mm)	Magnification on 22" LCD
1x	79	8.50	6.4 x 4.9	69x
3x	75	2.83	2.1 x 1.6	207x
5x	64	1.70	1.3 x 1.0	346x
10x	48	0.85	0.6 x 0.5	691x

Dual Camera optics (optional)

- In two steps electronically switchable magnification by factor 1:3.3
- Camera #1: 1/3" CCD camera
  - » H 752 x V 582 pixel
- Camera #2: 2/3" CCD camera
  - » H 752 x V 582 pixel
- Available lenses: 3x, 5x, 10x

Magnification variants of the Dual Camera optics (camera #1, detail mode / camera #2, overview mode)				
Optical magnification of the lens	Working distance (mm)	Pixel size (µm/pixel)	Field of view H x V (mm)	Magnification on 22" LCD
3x	75	2.12 / 7.03	1.6 x 1.2 / 5.3 x 4.1	278x / 84x
5x	64	1.27 / 4.22	1.0 x 0.7 / 3.2 x 2.5	463x / 138x
10x	48	0.64 / 2.11	0.5 x 0.4 / 1.6 x 1.2	925x / 281x

Through-The-Lens laser (TTL laser, optional)

Technical description

- Available only for systems equipped with fixed optics or Dual Camera optics
- Available for 5x and 10x lens
- Coaxial reflection into the optical path of the Vision-Sensor
- Measuring principle: Foucault method
- Functionality:
  - » Autofocus sensor for quick focussing of the Vision-Sensor and measuring heights, bore depths and flatness
  - » Scanning sensor for the contour and surface scanning
- Laser safety class 2, average output < 1 mW
- Red laser, wavelength 650 nm to 680 nm
- Spot size approx. 100 µm at 5x lens and accordingly approx. 50 µm at 10x lens
- Resolution ± 0.1 µm
- Measuring accuracy within E1 (at 10x lens)
- Average focus speed 0.2 s
- Scanning feature in conjunction with PC-DMIS CAD++ Vision

Chromatic  
White Light Sensor (CWS)  
(optional)

<sup>(1)</sup> Mutual measuring range  
Vision-Sensor ↔ CWS  
in X direction = 266 mm  
(X offset = 134 mm)

<sup>(2)</sup> Mutual measuring range  
Vision-Sensor ↔ CWS  
in X direction = 281 mm  
(X offset = 119 mm)

Technical description

- Optical sensor for focussing and scanning purposes according to the principle of chromatic length aberration of white light
- Surface independent and robust measurement with a resolution in the nanometer range

CWS measuring head	10 mm <sup>(1)</sup>	1 mm <sup>(1)</sup>	3 mm <sup>(2)</sup>	600 µm <sup>(2)</sup>	300 µm <sup>(2)</sup>
Working distance	70 mm	20.8 mm	22.5 mm	6.5 mm	4.5 mm
Resolution in Z direction	300 nm	35 nm	100 nm	20 nm	10 nm
Diameter of the CWS spot	24 µm	3,5 µm	12 µm	4 µm	5 µm

Touch-trigger probes  
TP200, HP-TM  
(optional)

Mutual measuring range  
Vision-Sensor ↔  
Touch-trigger probe  
in X direction = 335 mm  
(X offset = 65 mm)

TP200	HP-TM
Technical description	
<ul style="list-style-type: none"> <li>• 6-way touch-trigger probe using innovative micro strain gauge technology</li> <li>• Allows for small trigger forces and offers advanced triggering accuracy as well as long reliable operation</li> </ul>	<ul style="list-style-type: none"> <li>• 5-way touch-trigger probe: Sensor body and stylus holding module are magnetically connected to each other</li> <li>• Stylus holding modules available in four versions with different trigger forces</li> </ul>
Measuring accuracy (at 20°C, according to ISO 10360-2)	
$MPE_E = (2.9 + L/100) \mu\text{m}$ , $MPE_P = 2.9 \mu\text{m}$	
Mounting	
M8 thread (probe body), M2 thread (styli)	
Two stylus holding modules	Four stylus holding modules
LF low force SF standard force	LF low force SF standard force MF medium force EF extended force
Trigger force	
X, Y: 0.02 N / Z: 0.07 N (all modules)	0.055 N (LF module), 0.08 N (SF module), 0.10 N (MF module), 0.10 N (EF module)
Optional stylus module changing rack	
with 3 or 6 slots	HR-P4 or HR-P6 (with 4 or 6 slots)

Scanning probe  
HP-S-X1

Mutual measuring range  
Vision-Sensor ↔ HP-S-X1C  
in X direction = 335 mm  
(X offset = 65 mm)

HP-S-X1C
Technical description:
<ul style="list-style-type: none"> <li>• High accuracy 3D scanning probe head that supports single point probing, self-centering as well as continuous high-speed-scanning for fast and accurate form and profile measurements</li> <li>• Probe extensions in vertical and horizontal orientation are possible</li> </ul>
Probe head type: Analog
Stylus joint: M3
Resolution: < 0.1 µm
Measuring range: ± 2 mm in all axes
Linear stiffness: 1.2 N/mm
Stylus length range: Vertical: 20 - 115 mm, horizontal: up to 50 mm
Optional stylus module changing rack: HR-X1 with 3 or 6 slots

### Control system and safety regulations

- CNC controller:
  - » 3-4 axes microprocessor CNC with vector path control
- Safety equipment:
  - » Emergency-Stop circuit with Emergency-Stop button(s)
  - » Scale signal monitoring
  - » Double safety limit switches (magnetic/mechanical)
  - » Protective covers for the axes' drives
  - » Collision protection for touch-trigger probes
- Safety regulations:
  - » DIN EN ISO 12100-1 and -2 (Safety of machinery)
  - » DIN EN 60204-1 (Safety of machinery - Electrical equipment of machines)
  - » DIN EN ISO 13849-1 (Safety of machinery - Safety-related parts of control systems)
  - » DIN EN 61000-4-2 and -4 (Electromagnetic compatibility EMC, immunity of machines)
  - » DIN EN 55011 (Industrial, scientific and medical equipment - Radio-frequency disturbance characteristics)

### Optional equipment

- Vibration damping system
- Mechanical bearing CNC rotary table
- Stylus module changing rack
- Periphery:
  - » Worktable
  - » Printers, monitors
  - » Uninterruptible power supply (UPS)

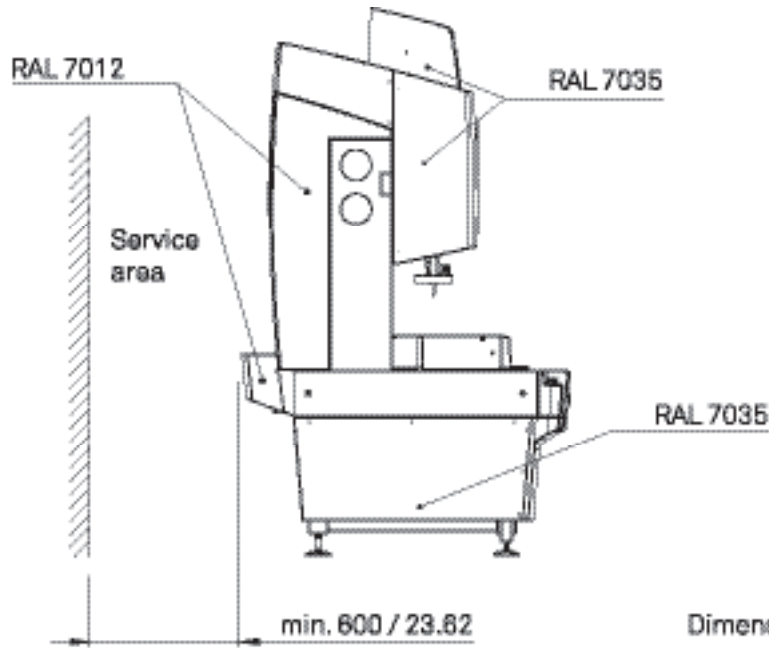

Dimensions in mm / inch

Optional worktable and monitor(s), differing variants possible.

Technical details subject to change without prior notice.

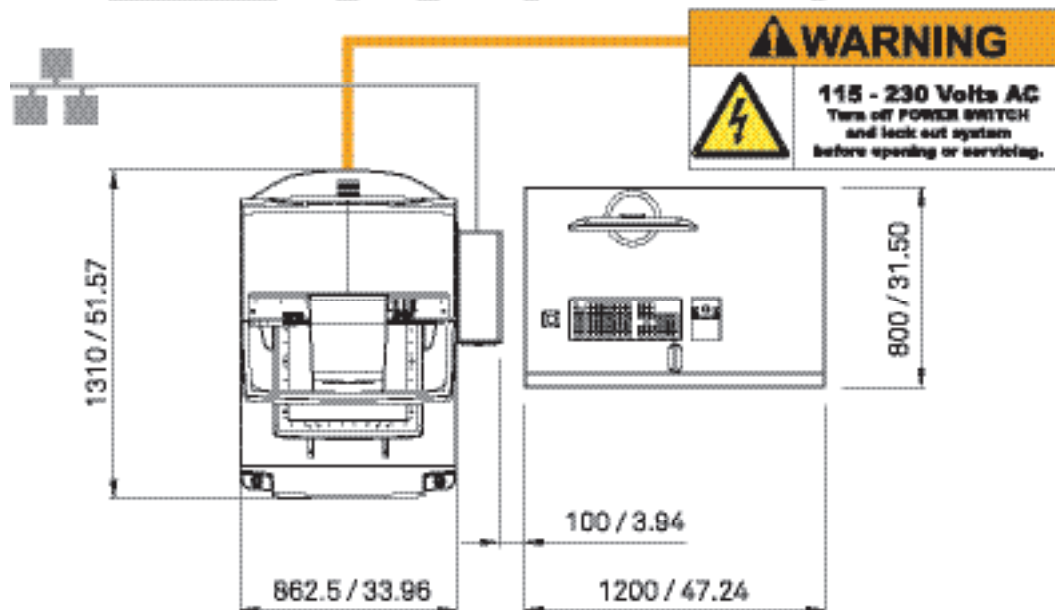

Dimensions in mm / inch  
 Technical details subject to change  
 without prior notice.

Offset camera + touch probe 65 mm / 2.56 inch  
 Offset camera + CWS\* 119 mm / 4.69 inch

\*CWS measuring heads 3 mm / 600 μm / 300 μm

- 1. Mutual measuring range of all sensors
- 2. Mutual measuring range camera + touch probe
- 3. Measuring range camera
- 4. Measuring range touch probe
- 5. Measuring range CWS\* (see offset table CWS)

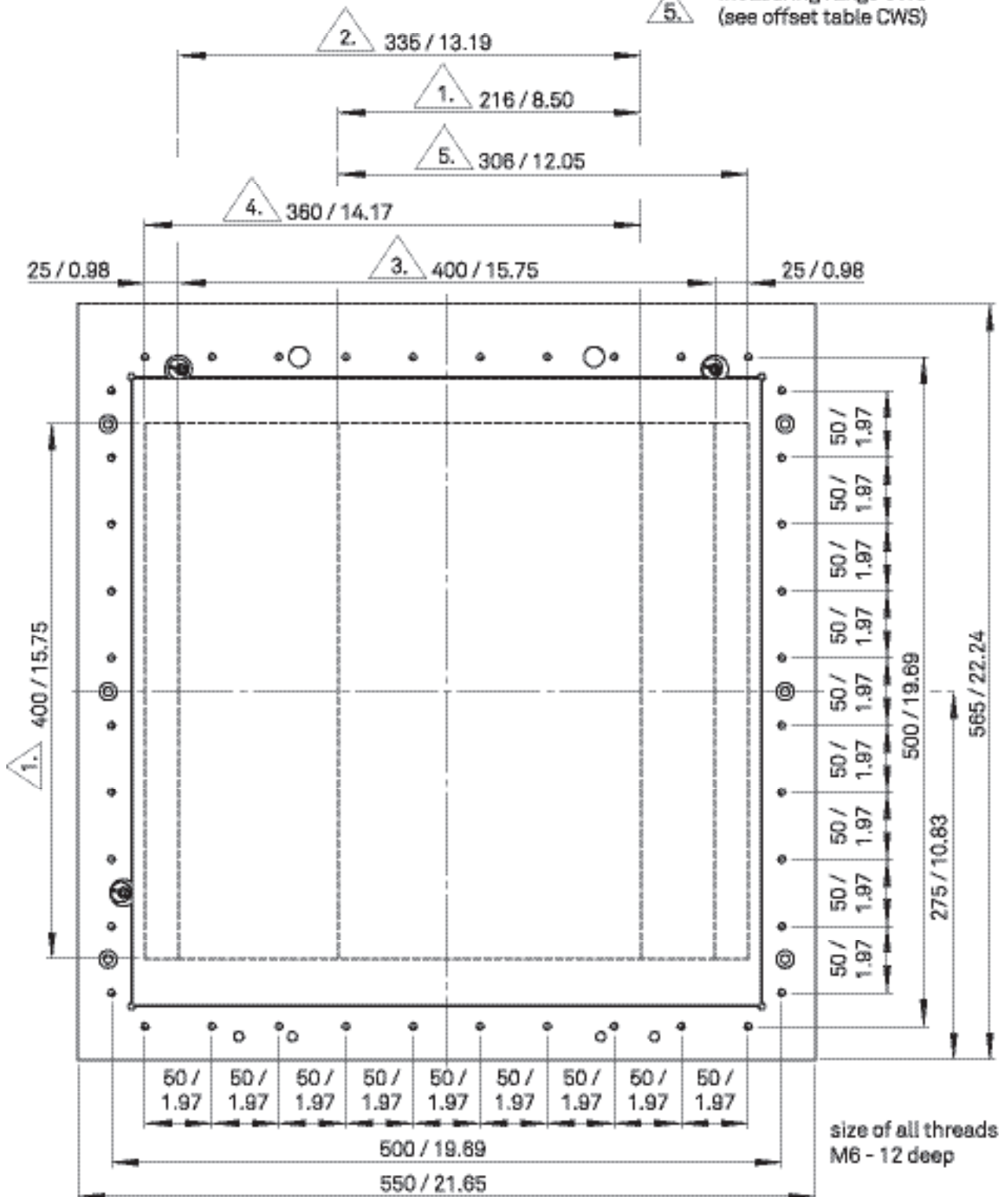



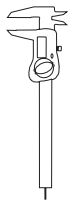

PRECISION MEASURING INSTRUMENTS



PORTABLE MEASURING ARMS

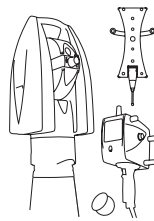

LASER TRACKERS & STATIONS



WHITE LIGHT SCANNERS

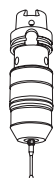

SENSORS

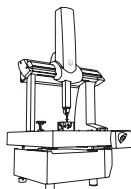

BRIDGE CMMS

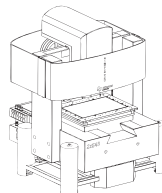

MULTISENSOR & OPTICAL SYSTEMS

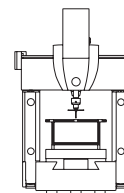

ULTRA HIGH ACCURACY CMMS

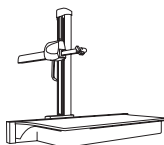

HORIZONTAL ARM CMMS

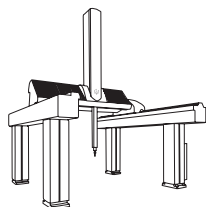

GANTRY CMMS

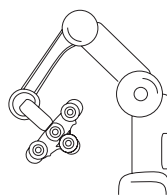

AUTOMATED APPLICATIONS

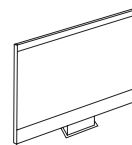

SOFTWARE SOLUTIONS



Hexagon Metrology offers a comprehensive range of products and services for all industrial metrology applications in sectors such as automotive, aerospace, energy and medical. We support our customers with actionable measurement information along the complete life cycle of a product – from development and design to production, assembly and final inspection.

With more than 20 production facilities and 70 Precision Centres for service and demonstrations, and a network of over 100 distribution partners on five continents, we empower our customers to fully control their manufacturing processes, enhancing the quality of products and increasing efficiency in manufacturing plants around the world.

For more information, visit [www.hexagonmetrology.com](http://www.hexagonmetrology.com)

Hexagon is a leading global provider of information technologies that drive productivity and quality across industrial and geospatial applications. Hexagon's solutions integrate sensors, software, domain knowledge and customer workflows into intelligent information ecosystems that deliver actionable information. They are used in a broad range of vital industries.

Hexagon (Nasdaq Stockholm: HEXA B) has more than 15,000 employees in 46 countries and net sales of approximately 2.6bn EUR.

Learn more at [www.hexagon.com](http://www.hexagon.com)