

GOM Acceptance Test for T-SCAN hawk

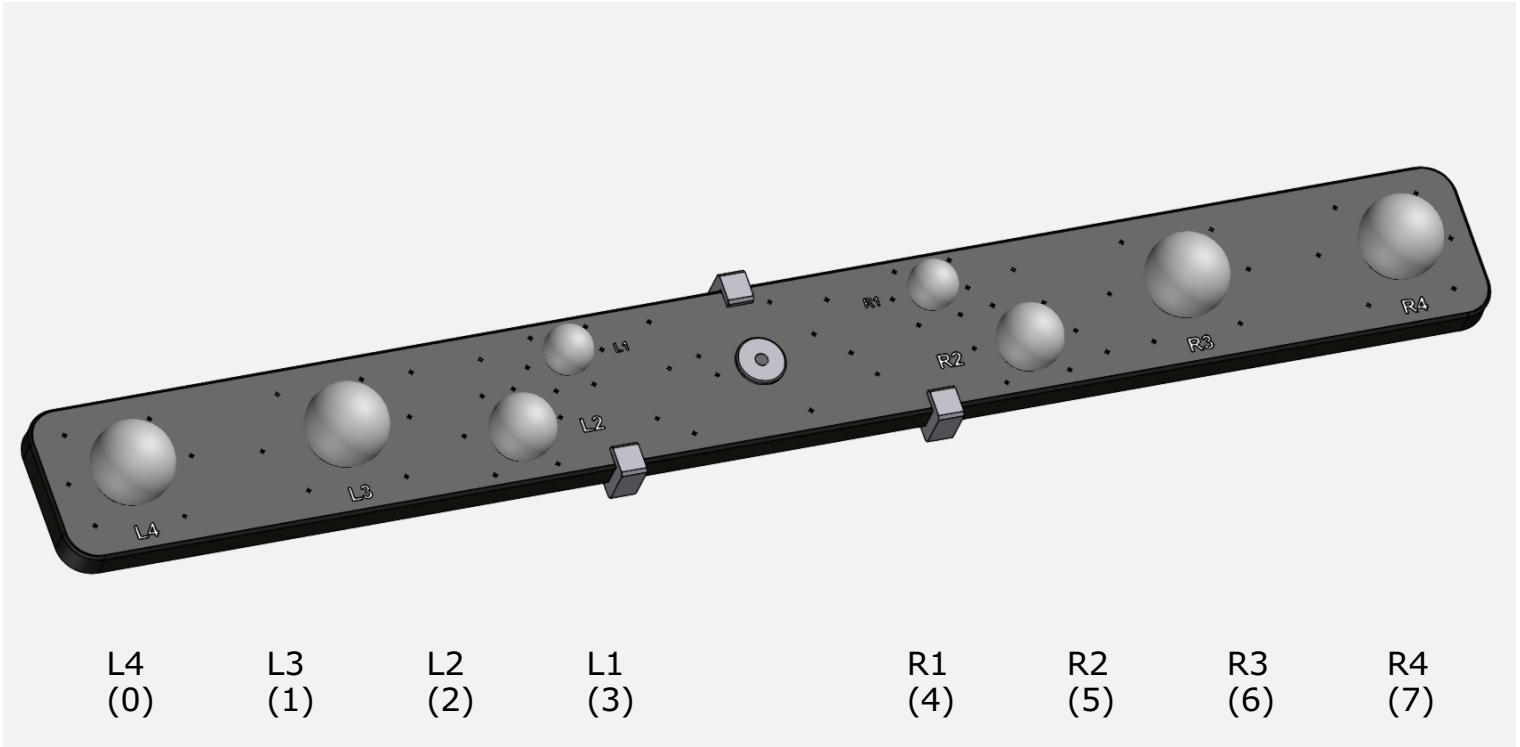

Inspector: Jurij Lebsak

Company: GOM GmbH

Location: Braunschweig

Date: 5/17/2022

System: T-Scan hawk

System SN: SK02UXKP0579

Calibration Plate SN: KC14010579

Software Version: GOM Software 2021 Hotfix 6

Artifact: PSA/900/Z5129

Calibration Mark: 24939/D-K-15007-01-00/2021-07

Guideline: with reference to ISO 10360

Result for the Length Measurement Error of 'M1' (Unidirectional)

Dimension	Nominal	Actual	Tol	Dev	Check	Out
E_uni_0_1_M1	+134.9638	+134.9679	0.0247	+0.0041	<input checked="" type="checkbox"/>	
E_uni_0_2_M1	+240.7996	+240.8054	0.0284	+0.0057	<input checked="" type="checkbox"/>	
E_uni_0_3_M1	+286.1378	+286.1431	0.0300	+0.0052	<input checked="" type="checkbox"/>	
E_uni_0_4_M1	+515.5911	+515.6064	0.0380	+0.0153	<input checked="" type="checkbox"/>	
E_uni_0_5_M1	+560.3345	+560.3509	0.0396	+0.0165	<input checked="" type="checkbox"/>	
E_uni_0_6_M1	+664.9812	+664.9965	0.0433	+0.0152	<input checked="" type="checkbox"/>	
E_uni_0_7_M1	+799.9866	+800.0041	0.0480	+0.0175	<input checked="" type="checkbox"/>	
E_uni_1_2_M1	+106.9158	+106.9175	0.0237	+0.0018	<input checked="" type="checkbox"/>	
E_uni_1_3_M1	+152.2027	+152.2032	0.0253	+0.0005	<input checked="" type="checkbox"/>	
E_uni_1_4_M1	+380.8540	+380.8648	0.0333	+0.0108	<input checked="" type="checkbox"/>	
E_uni_1_5_M1	+425.4870	+425.4995	0.0349	+0.0125	<input checked="" type="checkbox"/>	
E_uni_1_6_M1	+530.0175	+530.0286	0.0386	+0.0111	<input checked="" type="checkbox"/>	
E_uni_1_7_M1	+665.0229	+665.0362	0.0433	+0.0134	<input checked="" type="checkbox"/>	
E_uni_2_3_M1	+63.7368	+63.7336	0.0222	-0.0032	<input checked="" type="checkbox"/>	
E_uni_2_4_M1	+278.6724	+278.6805	0.0298	+0.0081	<input checked="" type="checkbox"/>	
E_uni_2_5_M1	+320.0193	+320.0296	0.0312	+0.0104	<input checked="" type="checkbox"/>	
E_uni_2_6_M1	+425.5105	+425.5195	0.0349	+0.0090	<input checked="" type="checkbox"/>	
E_uni_2_7_M1	+560.3995	+560.4109	0.0396	+0.0115	<input checked="" type="checkbox"/>	
E_uni_3_4_M1	+229.9700	+229.9803	0.0281	+0.0103	<input checked="" type="checkbox"/>	
E_uni_3_5_M1	+278.6663	+278.6776	0.0298	+0.0113	<input checked="" type="checkbox"/>	
E_uni_3_6_M1	+380.8706	+380.8804	0.0333	+0.0099	<input checked="" type="checkbox"/>	
E_uni_3_7_M1	+515.6469	+515.6588	0.0380	+0.0119	<input checked="" type="checkbox"/>	
E_uni_4_5_M1	+63.7271	+63.7260	0.0222	-0.0011	<input checked="" type="checkbox"/>	
E_uni_4_6_M1	+152.2176	+152.2164	0.0253	-0.0012	<input checked="" type="checkbox"/>	
E_uni_4_7_M1	+286.1908	+286.1918	0.0300	+0.0009	<input checked="" type="checkbox"/>	
E_uni_5_6_M1	+106.9385	+106.9376	0.0237	-0.0009	<input checked="" type="checkbox"/>	
E_uni_5_7_M1	+240.8642	+240.8659	0.0284	+0.0016	<input checked="" type="checkbox"/>	
E_uni_6_7_M1	+135.0055	+135.0077	0.0247	+0.0022	<input checked="" type="checkbox"/>	

Length unit: mm

Result for the Length Measurement Error of 'M2' (Unidirectional)

Dimension	Nominal	Actual	Tol	Dev	Check	Out
E_uni_0_1_M2	+134.9638	+134.9681	0.0247	+0.0043	<input checked="" type="checkbox"/>	
E_uni_0_2_M2	+240.7996	+240.8045	0.0284	+0.0049	<input checked="" type="checkbox"/>	
E_uni_0_3_M2	+286.1378	+286.1392	0.0300	+0.0014	<input checked="" type="checkbox"/>	
E_uni_0_4_M2	+515.5911	+515.5992	0.0380	+0.0081	<input checked="" type="checkbox"/>	
E_uni_0_5_M2	+560.3345	+560.3436	0.0396	+0.0092	<input checked="" type="checkbox"/>	
E_uni_0_6_M2	+664.9812	+664.9911	0.0433	+0.0099	<input checked="" type="checkbox"/>	
E_uni_0_7_M2	+799.9866	+799.9948	0.0480	+0.0081	<input checked="" type="checkbox"/>	
E_uni_1_2_M2	+106.9158	+106.9159	0.0237	+0.0002	<input checked="" type="checkbox"/>	
E_uni_1_3_M2	+152.2027	+152.1996	0.0253	-0.0031	<input checked="" type="checkbox"/>	
E_uni_1_4_M2	+380.8540	+380.8575	0.0333	+0.0035	<input checked="" type="checkbox"/>	
E_uni_1_5_M2	+425.4870	+425.4919	0.0349	+0.0049	<input checked="" type="checkbox"/>	
E_uni_1_6_M2	+530.0175	+530.0230	0.0386	+0.0056	<input checked="" type="checkbox"/>	
E_uni_1_7_M2	+665.0229	+665.0267	0.0433	+0.0038	<input checked="" type="checkbox"/>	
E_uni_2_3_M2	+63.7368	+63.7316	0.0222	-0.0052	<input checked="" type="checkbox"/>	
E_uni_2_4_M2	+278.6724	+278.6739	0.0298	+0.0015	<input checked="" type="checkbox"/>	
E_uni_2_5_M2	+320.0193	+320.0232	0.0312	+0.0039	<input checked="" type="checkbox"/>	
E_uni_2_6_M2	+425.5105	+425.5149	0.0349	+0.0044	<input checked="" type="checkbox"/>	
E_uni_2_7_M2	+560.3995	+560.4023	0.0396	+0.0028	<input checked="" type="checkbox"/>	
E_uni_3_4_M2	+229.9700	+229.9773	0.0281	+0.0072	<input checked="" type="checkbox"/>	
E_uni_3_5_M2	+278.6663	+278.6748	0.0298	+0.0085	<input checked="" type="checkbox"/>	
E_uni_3_6_M2	+380.8706	+380.8797	0.0333	+0.0091	<input checked="" type="checkbox"/>	
E_uni_3_7_M2	+515.6469	+515.6543	0.0380	+0.0074	<input checked="" type="checkbox"/>	
E_uni_4_5_M2	+63.7271	+63.7256	0.0222	-0.0015	<input checked="" type="checkbox"/>	
E_uni_4_6_M2	+152.2176	+152.2188	0.0253	+0.0011	<input checked="" type="checkbox"/>	
E_uni_4_7_M2	+286.1908	+286.1906	0.0300	-0.0002	<input checked="" type="checkbox"/>	
E_uni_5_6_M2	+106.9385	+106.9393	0.0237	+0.0008	<input checked="" type="checkbox"/>	
E_uni_5_7_M2	+240.8642	+240.8633	0.0284	-0.0009	<input checked="" type="checkbox"/>	
E_uni_6_7_M2	+135.0055	+135.0038	0.0247	-0.0017	<input checked="" type="checkbox"/>	

Length unit: mm

Result for the Length Measurement Error of 'M3' (Unidirectional)

Dimension	Nominal	Actual	Tol	Dev	Check	Out
E_uni_0_1_M3	+134.9638	+134.9629	0.0247	-0.0008	<input checked="" type="checkbox"/>	
E_uni_0_2_M3	+240.7996	+240.8028	0.0284	+0.0031	<input checked="" type="checkbox"/>	
E_uni_0_3_M3	+286.1378	+286.1372	0.0300	-0.0006	<input checked="" type="checkbox"/>	
E_uni_0_4_M3	+515.5911	+515.5971	0.0380	+0.0060	<input checked="" type="checkbox"/>	
E_uni_0_5_M3	+560.3345	+560.3384	0.0396	+0.0040	<input checked="" type="checkbox"/>	
E_uni_0_6_M3	+664.9812	+664.9828	0.0433	+0.0016	<input checked="" type="checkbox"/>	
E_uni_0_7_M3	+799.9866	+799.9896	0.0480	+0.0029	<input checked="" type="checkbox"/>	
E_uni_1_2_M3	+106.9158	+106.9195	0.0237	+0.0038	<input checked="" type="checkbox"/>	
E_uni_1_3_M3	+152.2027	+152.2027	0.0253	-0.0001	<input checked="" type="checkbox"/>	
E_uni_1_4_M3	+380.8540	+380.8607	0.0333	+0.0067	<input checked="" type="checkbox"/>	
E_uni_1_5_M3	+425.4870	+425.4918	0.0349	+0.0048	<input checked="" type="checkbox"/>	
E_uni_1_6_M3	+530.0175	+530.0199	0.0386	+0.0024	<input checked="" type="checkbox"/>	
E_uni_1_7_M3	+665.0229	+665.0267	0.0433	+0.0038	<input checked="" type="checkbox"/>	
E_uni_2_3_M3	+63.7368	+63.7326	0.0222	-0.0042	<input checked="" type="checkbox"/>	
E_uni_2_4_M3	+278.6724	+278.6749	0.0298	+0.0025	<input checked="" type="checkbox"/>	
E_uni_2_5_M3	+320.0193	+320.0200	0.0312	+0.0008	<input checked="" type="checkbox"/>	
E_uni_2_6_M3	+425.5105	+425.5091	0.0349	-0.0014	<input checked="" type="checkbox"/>	
E_uni_2_7_M3	+560.3995	+560.3995	0.0396	-0.0000	<input checked="" type="checkbox"/>	
E_uni_3_4_M3	+229.9700	+229.9766	0.0281	+0.0066	<input checked="" type="checkbox"/>	
E_uni_3_5_M3	+278.6663	+278.6707	0.0298	+0.0044	<input checked="" type="checkbox"/>	
E_uni_3_6_M3	+380.8706	+380.8725	0.0333	+0.0020	<input checked="" type="checkbox"/>	
E_uni_3_7_M3	+515.6469	+515.6502	0.0380	+0.0032	<input checked="" type="checkbox"/>	
E_uni_4_5_M3	+63.7271	+63.7257	0.0222	-0.0015	<input checked="" type="checkbox"/>	
E_uni_4_6_M3	+152.2176	+152.2128	0.0253	-0.0048	<input checked="" type="checkbox"/>	
E_uni_4_7_M3	+286.1908	+286.1873	0.0300	-0.0035	<input checked="" type="checkbox"/>	
E_uni_5_6_M3	+106.9385	+106.9370	0.0237	-0.0015	<input checked="" type="checkbox"/>	
E_uni_5_7_M3	+240.8642	+240.8639	0.0284	-0.0004	<input checked="" type="checkbox"/>	
E_uni_6_7_M3	+135.0055	+135.0069	0.0247	+0.0014	<input checked="" type="checkbox"/>	

Length unit: mm

Result for the Length Measurement Error of 'M4' (Unidirectional)

Dimension	Nominal	Actual	Tol	Dev	Check	Out
E_uni_0_1_M4	+134.9638	+134.9655	0.0247	+0.0018	<input checked="" type="checkbox"/>	
E_uni_0_2_M4	+240.7996	+240.8043	0.0284	+0.0046	<input checked="" type="checkbox"/>	
E_uni_0_3_M4	+286.1378	+286.1377	0.0300	-0.0001	<input checked="" type="checkbox"/>	
E_uni_0_4_M4	+515.5911	+515.5940	0.0380	+0.0029	<input checked="" type="checkbox"/>	
E_uni_0_5_M4	+560.3345	+560.3402	0.0396	+0.0057	<input checked="" type="checkbox"/>	
E_uni_0_6_M4	+664.9812	+664.9846	0.0433	+0.0034	<input checked="" type="checkbox"/>	
E_uni_0_7_M4	+799.9866	+799.9920	0.0480	+0.0054	<input checked="" type="checkbox"/>	
E_uni_1_2_M4	+106.9158	+106.9186	0.0237	+0.0029	<input checked="" type="checkbox"/>	
E_uni_1_3_M4	+152.2027	+152.2000	0.0253	-0.0028	<input checked="" type="checkbox"/>	
E_uni_1_4_M4	+380.8540	+380.8547	0.0333	+0.0007	<input checked="" type="checkbox"/>	
E_uni_1_5_M4	+425.4870	+425.4911	0.0349	+0.0040	<input checked="" type="checkbox"/>	
E_uni_1_6_M4	+530.0175	+530.0190	0.0386	+0.0016	<input checked="" type="checkbox"/>	
E_uni_1_7_M4	+665.0229	+665.0265	0.0433	+0.0036	<input checked="" type="checkbox"/>	
E_uni_2_3_M4	+63.7368	+63.7289	0.0222	-0.0079	<input checked="" type="checkbox"/>	
E_uni_2_4_M4	+278.6724	+278.6693	0.0298	-0.0031	<input checked="" type="checkbox"/>	
E_uni_2_5_M4	+320.0193	+320.0201	0.0312	+0.0008	<input checked="" type="checkbox"/>	
E_uni_2_6_M4	+425.5105	+425.5091	0.0349	-0.0014	<input checked="" type="checkbox"/>	
E_uni_2_7_M4	+560.3995	+560.4002	0.0396	+0.0007	<input checked="" type="checkbox"/>	
E_uni_3_4_M4	+229.9700	+229.9731	0.0281	+0.0031	<input checked="" type="checkbox"/>	
E_uni_3_5_M4	+278.6663	+278.6717	0.0298	+0.0054	<input checked="" type="checkbox"/>	
E_uni_3_6_M4	+380.8706	+380.8737	0.0333	+0.0031	<input checked="" type="checkbox"/>	
E_uni_3_7_M4	+515.6469	+515.6521	0.0380	+0.0051	<input checked="" type="checkbox"/>	
E_uni_4_5_M4	+63.7271	+63.7266	0.0222	-0.0005	<input checked="" type="checkbox"/>	
E_uni_4_6_M4	+152.2176	+152.2168	0.0253	-0.0009	<input checked="" type="checkbox"/>	
E_uni_4_7_M4	+286.1908	+286.1924	0.0300	+0.0016	<input checked="" type="checkbox"/>	
E_uni_5_6_M4	+106.9385	+106.9372	0.0237	-0.0014	<input checked="" type="checkbox"/>	
E_uni_5_7_M4	+240.8642	+240.8647	0.0284	+0.0005	<input checked="" type="checkbox"/>	
E_uni_6_7_M4	+135.0055	+135.0075	0.0247	+0.0020	<input checked="" type="checkbox"/>	

Length unit: mm

Result for the Length Measurement Error of 'M5' (Unidirectional)

Dimension	Nominal	Actual	Tol	Dev	Check	Out
E_uni_0_1_M5	+134.9638	+134.9623	0.0247	-0.0014	<input checked="" type="checkbox"/>	
E_uni_0_2_M5	+240.7996	+240.8002	0.0284	+0.0006	<input checked="" type="checkbox"/>	
E_uni_0_3_M5	+286.1378	+286.1348	0.0300	-0.0031	<input checked="" type="checkbox"/>	
E_uni_0_4_M5	+515.5911	+515.5884	0.0380	-0.0027	<input checked="" type="checkbox"/>	
E_uni_0_5_M5	+560.3345	+560.3300	0.0396	-0.0045	<input checked="" type="checkbox"/>	
E_uni_0_6_M5	+664.9812	+664.9724	0.0433	-0.0088	<input checked="" type="checkbox"/>	
E_uni_0_7_M5	+799.9866	+799.9730	0.0480	-0.0136	<input checked="" type="checkbox"/>	
E_uni_1_2_M5	+106.9158	+106.9175	0.0237	+0.0018	<input checked="" type="checkbox"/>	
E_uni_1_3_M5	+152.2027	+152.2007	0.0253	-0.0021	<input checked="" type="checkbox"/>	
E_uni_1_4_M5	+380.8540	+380.8523	0.0333	-0.0017	<input checked="" type="checkbox"/>	
E_uni_1_5_M5	+425.4870	+425.4839	0.0349	-0.0031	<input checked="" type="checkbox"/>	
E_uni_1_6_M5	+530.0175	+530.0101	0.0386	-0.0074	<input checked="" type="checkbox"/>	
E_uni_1_7_M5	+665.0229	+665.0106	0.0433	-0.0122	<input checked="" type="checkbox"/>	
E_uni_2_3_M5	+63.7368	+63.7323	0.0222	-0.0045	<input checked="" type="checkbox"/>	
E_uni_2_4_M5	+278.6724	+278.6682	0.0298	-0.0042	<input checked="" type="checkbox"/>	
E_uni_2_5_M5	+320.0193	+320.0141	0.0312	-0.0051	<input checked="" type="checkbox"/>	
E_uni_2_6_M5	+425.5105	+425.5011	0.0349	-0.0094	<input checked="" type="checkbox"/>	
E_uni_2_7_M5	+560.3995	+560.3854	0.0396	-0.0141	<input checked="" type="checkbox"/>	
E_uni_3_4_M5	+229.9700	+229.9711	0.0281	+0.0010	<input checked="" type="checkbox"/>	
E_uni_3_5_M5	+278.6663	+278.6661	0.0298	-0.0002	<input checked="" type="checkbox"/>	
E_uni_3_6_M5	+380.8706	+380.8665	0.0333	-0.0041	<input checked="" type="checkbox"/>	
E_uni_3_7_M5	+515.6469	+515.6382	0.0380	-0.0088	<input checked="" type="checkbox"/>	
E_uni_4_5_M5	+63.7271	+63.7257	0.0222	-0.0014	<input checked="" type="checkbox"/>	
E_uni_4_6_M5	+152.2176	+152.2128	0.0253	-0.0048	<input checked="" type="checkbox"/>	
E_uni_4_7_M5	+286.1908	+286.1813	0.0300	-0.0095	<input checked="" type="checkbox"/>	
E_uni_5_6_M5	+106.9385	+106.9345	0.0237	-0.0041	<input checked="" type="checkbox"/>	
E_uni_5_7_M5	+240.8642	+240.8555	0.0284	-0.0087	<input checked="" type="checkbox"/>	
E_uni_6_7_M5	+135.0055	+135.0006	0.0247	-0.0049	<input checked="" type="checkbox"/>	

Length unit: mm

Results for the Repetition Range of 'POS1' (Unidirectional)

Dimension	Tol	Dev	Check	Out
R_0_uni_0_1_POS1	0.0247	+0.0057	<input type="checkbox"/>	
R_0_uni_0_2_POS1	0.0284	+0.0051	<input type="checkbox"/>	
R_0_uni_0_3_POS1	0.0300	+0.0083	<input type="checkbox"/>	
R_0_uni_0_4_POS1	0.0380	+0.0180	<input type="checkbox"/>	
R_0_uni_0_5_POS1	0.0396	+0.0210	<input type="checkbox"/>	
R_0_uni_0_6_POS1	0.0433	+0.0240	<input type="checkbox"/>	
R_0_uni_0_7_POS1	0.0480	+0.0311	<input type="checkbox"/>	
R_0_uni_1_2_POS1	0.0237	+0.0036	<input type="checkbox"/>	
R_0_uni_1_3_POS1	0.0253	+0.0036	<input type="checkbox"/>	
R_0_uni_1_4_POS1	0.0333	+0.0125	<input type="checkbox"/>	
R_0_uni_1_5_POS1	0.0349	+0.0156	<input type="checkbox"/>	
R_0_uni_1_6_POS1	0.0386	+0.0185	<input type="checkbox"/>	
R_0_uni_1_7_POS1	0.0433	+0.0256	<input type="checkbox"/>	
R_0_uni_2_3_POS1	0.0222	+0.0047	<input type="checkbox"/>	
R_0_uni_2_4_POS1	0.0298	+0.0123	<input type="checkbox"/>	
R_0_uni_2_5_POS1	0.0312	+0.0155	<input type="checkbox"/>	
R_0_uni_2_6_POS1	0.0349	+0.0184	<input type="checkbox"/>	
R_0_uni_2_7_POS1	0.0396	+0.0256	<input type="checkbox"/>	
R_0_uni_3_4_POS1	0.0281	+0.0092	<input type="checkbox"/>	
R_0_uni_3_5_POS1	0.0298	+0.0115	<input type="checkbox"/>	
R_0_uni_3_6_POS1	0.0333	+0.0140	<input type="checkbox"/>	
R_0_uni_3_7_POS1	0.0380	+0.0206	<input type="checkbox"/>	
R_0_uni_4_5_POS1	0.0222	+0.0010	<input type="checkbox"/>	
R_0_uni_4_6_POS1	0.0253	+0.0060	<input type="checkbox"/>	
R_0_uni_4_7_POS1	0.0300	+0.0111	<input type="checkbox"/>	
R_0_uni_5_6_POS1	0.0237	+0.0048	<input type="checkbox"/>	
R_0_uni_5_7_POS1	0.0284	+0.0103	<input type="checkbox"/>	
R_0_uni_6_7_POS1	0.0247	+0.0071	<input type="checkbox"/>	

Length unit: mm