



stratasys®

Eden260VS

3D Printing System



Copyright

Copyright © 2018 Stratasys Ltd. All rights reserved.

This documentation contains proprietary information of Stratasys Ltd. This information is supplied solely to assist authorized users of this Stratasys 3D printing system. No part of this document may be used for other purposes, and it may not be disclosed to other parties.

The specifications on which this document is based are subject to change without notice.

No part of this book may be reproduced in any form or by any means, nor stored in a database or retrieval system, without prior permission in writing from Stratasys Ltd.

If this document is distributed as a PDF file, you may print it for internal use.

April 2018

DOC-09669 Rev. H

Trademarks

The following are registered trademarks of Stratasys Ltd.: Stratasys[®], Objet[®], FullCure[®].

All names of products and services cited in this book are trademarks or registered trademarks of their respective companies.

Feedback

If you have any questions or comments about the way information is presented in this document, or if you have any suggestions for future editions, please send a message to c-support@stratasys.com.

Contents

- Introduction 5**
 - About this Guide 5
 - Installation and Training Schedule 5
- Physical Description 6**
 - Size and Weight 6
- Shipment and Delivery 7**
 - Shipping Information and Customer Responsibility 7
 - Shipping Pallet 7
 - Lifting Equipment 7
 - Unloading 8
- Installation Area 9**
 - Floor Plan (Printer Area) 10
- Workstation Requirements 11**
- Electrical Requirements 12**
 - Power 12
 - Grounding 12
 - Circuit Breaker 13
 - Residual Current Device (RCD) 13
 - Power Connection 13
 - UPS (Uninterrupted Power Supply) 13
- Communication Lines 15**
 - Local Area Network 15
 - Telephone 15
- Environmental Conditions 16**
 - Temperature and Humidity 16
 - Air Quality 16
 - Noise Level 16
- Accessories and Utilities 17**
 - Start-Up Kit 17
 - Exhaust Adapter 17
 - Eyewash Station 17
 - Compressed Air 18
 - Fire Safety Equipment 18

Materials Handling and Storage	19
Printing Materials	19
Cleaning Solvent	19
Site Preparation Checklist	20

Introduction

About this Guide

The information and requirements provided in this document ensure proper installation and operation of the Eden260VS 3D printing system. The customer is responsible for preparing the site as described in this document, and according to any applicable local regulations.

If you have any questions about the information in this document, contact your Stratasys representative.

All site requirements must be met before the installation date. The Site Preparation Checklist should be submitted to your Stratasys representative. Shipping will be arranged after the checklist is received by Stratasys.

Non-compliance with requirements specified in this document may result in additional installation charges.

Installation and Training Schedule

- Basic installation and adjustment: 1 work day
- Operator training (operation and maintenance): 1 work day
- Product designer training: ½ work day
- Practice under supervision —1 work day

Physical Description

The Eden260VS 3D printing system consists of the following main components:

- printer
- printer computer (built into the printer)
- printer-server workstation (provided by the customer)

Figure 1 Eden260V printers



Size and Weight

Table 1 Size and weight

Unit	W × H × D (cm)	W × H × D (inch)	Weight (kg/lb)
Eden260V	87 × 120 × 73.5	34.2 × 47.2 × 29	254 kg / 559 lb

The following table shows the size and weight information for Eden260V printers.



- W = Width; H = Height; D = Depth
- The depth measurement does not include the fan adapter assembly. If the fan adapter is ordered, the depth measurement increases to 80 cm/31.5 inches (see "Exhaust Adapter" on page 17).

Shipment and Delivery

Shipping Information and Customer Responsibility

Shipment to the customer will be arranged by a Stratasys distributor as indicated in the “ship to” part of the invoice. The customer is responsible for providing detailed delivery information, including, whether or not there is loading dock at the delivery site.

The customer is responsible for transporting the printer to a suitable installation site. Upon request, your Stratasys service provider will advise regarding these matters.



Note:

Only Stratasys-certified Customer Support Engineers are authorized to unpack and install equipment supplied.

Shipping Pallet

The following table shows the approximate size and weight of the printing system mounted on a pallet.

Table 2 Size and weight of printer on shipping pallet

Unit	W × H × D (cm)	W × H × D (inch)	Weight (kg/lb)
Eden260V	112 × 143 × 89	44.1 × 56.3 × 35	300 kg / 660 lb



W = Width; H = Height; D = Depth

Lifting Equipment

A forklift or hand-operated pallet truck with the following specifications is required:

- lifting capacity: 500 kg (1100 lb)
- extension: 150 cm (60 in.)

Unloading

The unloading area should be a level surface.

An area of 10 m² (108 sq ft) is required for the forklift to remove the printer from the delivery truck.

A clearance of 120 cm (4 ft) around the back and sides of the packaging is required for unpacking the printer.

A clearance of 180 cm (6 ft) from the front is required for unloading the printer from the pallet.

The installation location must be accessible from the unloading area. The customer is responsible for unloading the printer from the truck and transferring it to the installation location.

Installation Area

The installation area should be free of sources of vibration and electromagnetic interference that could affect the proper functioning of the printer.

The floor gradient should be less than 0.5% (5 mm per meter).

The floor should be stable and able to bear the load of the printer. The minimum floor load is 560 kg/m² (115 lb/ft²).

The server workstation and the printer should be located in the same room.

The cable between the server workstation and the printer should not exceed 5 meters (16 feet). The communication cable provided should not be extended or replaced with a longer cable.

Clearance around and above the printer should ensure convenient access and servicing.

The area around the printer should remain dry at all times. Do not place the cleaning station within 5 meters (16 feet) of the printer.

Shelves and cabinets are recommended near the printer for convenient storage of tools, parts, accessories, manuals, and materials.

Floor Plan (Printer Area)

The following is a sample floor plan, showing the 3D printing system—the printer and the workstation. The dimensions shown in the figure are the minimum clearance requirements.

Figure 2 Printer floor plan (sample, not to scale)

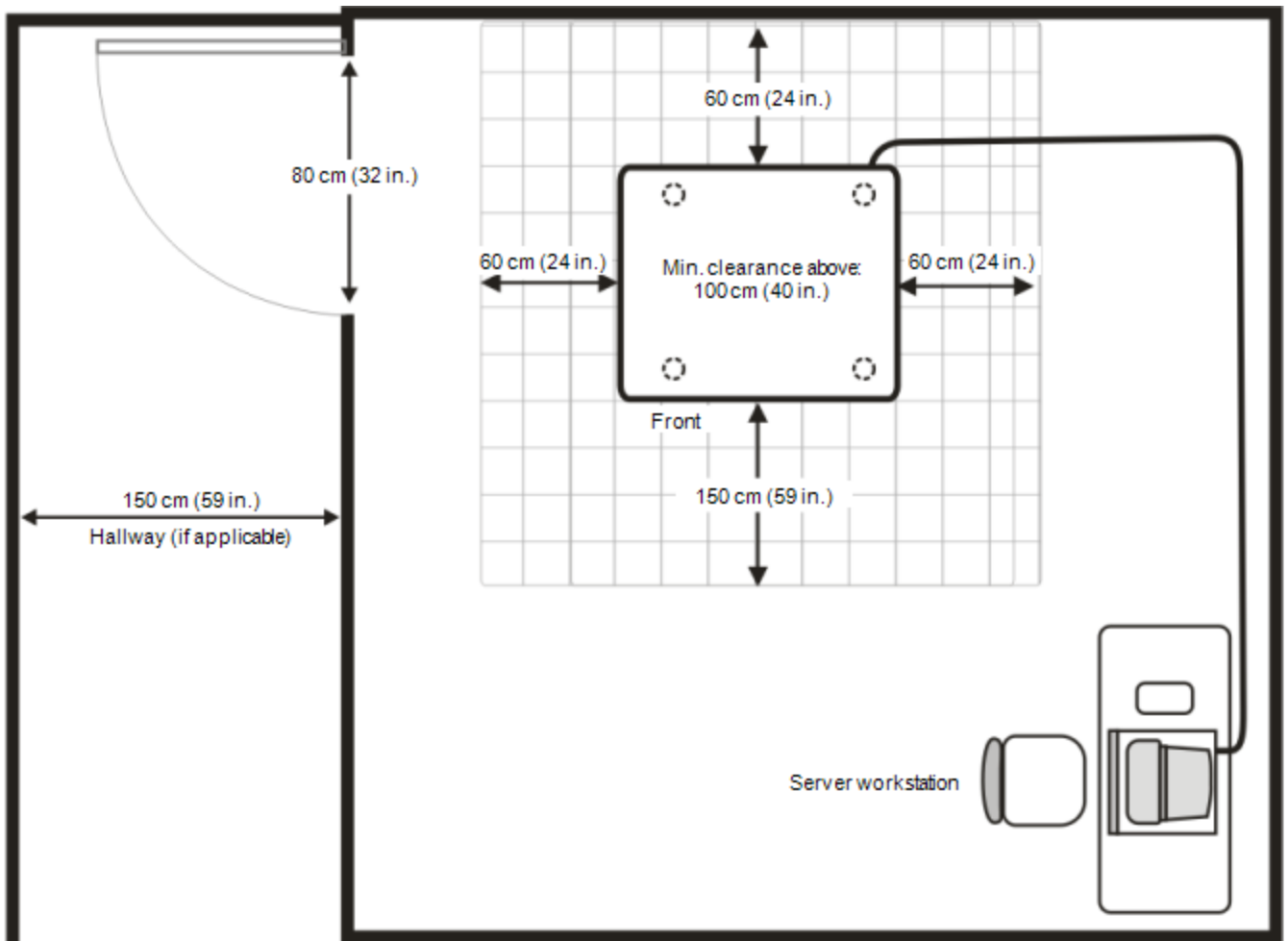

Workstation Requirements

The customer is responsible for supplying a computer with the following specifications for the server workstation.

	Requirement
Computer Type	Standard desktop PC ¹
Processor	Intel® Core™ i5 or higher
Operating System	Windows® 7 64-bit, Windows® 8.1 64-bit, or Windows® 10 64-bit ² Use a professional edition of Windows® only.
RAM	8 GB or more ²
Graphics Card ³	Open GL® Memory: 1 GB or more; 2 GB recommended for dental applications
	For server workstation: VGA connector ⁴
Optical Drive	CD/DVD ROM
HDD/SSD	80 GB or more (minimum free space on disk: 40 GB)
Network Card	LAN TCP/IP (2 network cards for server workstation; 1 network card for each client workstation)
Mouse/Keyboard Connection	USB
Monitor Cable	One cable with VGA connector
Anti-virus	Recommended: TrendMicro, Eset NOD32, AVG, Kaspersky ⁵

Administrator privileges are required on the server workstation. These specifications are also recommended for any additional client workstations running Objet Studio.

¹ For systems using a KVM switch box to control both the built-in printer computer and the server workstation with same keyboard-monitor-mouse set: All-in-one computer, wireless mouse and wireless keyboard cannot be used.

² A 64-bit operating system is recommended, to utilize 8 GB of memory.

PolyJet Studio running on a 32-bit application can utilize only 4 GB of memory.

³ The following graphics cards were also tested in Stratasys labs:

- NVIDIA® Quadro® Family—FX570, FX1700
- NVIDIA® GeForce® Family—6200 TurboCache™, 7300 GT, GTX 285
- Intel® Express Chipset—82915G/GV, 82910GL, Q965, Q963, Q35, Q45, Q43, 82852, 82855
- ATI Radeon™ HD 5670, HD 5970
- AMD Radeon™ E6760

⁴ For systems using a KVM switch box. If the server workstation has a DVI video connector, a VGA adapter is needed.

⁵ Most anti-virus programs can be used. Programs by vendors listed were tested in Stratasys labs.

Electrical Requirements

The customer is responsible for ensuring that all tasks described in this section are performed by qualified personnel.

Power

A stable, reliable source of power is required. Power to the UPS (or printer) should be supplied directly from the main electrical panel. Other electrical outlets should not be connected to the line.

Printer power rating:

- 100–120 VAC, 50–60 Hz, 14 A, 1 phase
- 220–240 VAC, 50–60 Hz, 7 A, 1 phase

Printer short circuit rating: 1000 A

If the power at the facility does not support the above specifications, contact your Stratasys specialist.

**Important:**

The diagram below shows the required connection to the power socket. Make sure that the electrician sees this before installing the printer.

Figure 3 Connection diagram

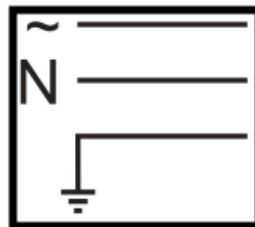

Grounding

The printer is grounded through a single-phase, AC plug. Make sure that the AC outlet is properly grounded, in accordance with local electrical codes.

Circuit Breaker

A Type-C circuit breaker with the following specification is required on the power line (subject to the local electrical code).

Table 3 Circuit breaker

Voltage	Circuit Breaker
100–120 VAC	15 A or 16 A
220-240 VAC	10 A

Residual Current Device (RCD)

The wall outlet must be connected to a residual current device (RCD).

Power Connection

The customer must provide an appropriate power plug and have it installed by a certified electrician.

The following electrical outlets are required:

- one outlet behind the printer
- three outlets close to the printer (for the workstation, monitor, and servicing equipment)

UPS (Uninterrupted Power Supply)

It is recommended that the printer is powered through a UPS unit, provided by the customer. If installed, the UPS ensures that—

- the quality of printing is not affected by power fluctuations from the mains.
- the printer can be programmed to perform “graceful shutdown” in the event of a power failure. This is possible with some UPSs, such as the third-party Eaton PW9130G3000T.

The UPS specifications are listed below.

Table 4 UPS requirements

Voltage ¹	Current	Power	Power Factor ²	Bridging Time	Interface
100–120 VAC	16 Amps	1500 VA	0.9	15 minutes	USB port ³
220–240 VAC	8 Amps				Compatible with Windows® 7
					Command-line control ⁴

These UPS systems were tested at Stratasys and meet the above requirements:

- Eaton PW9130G3000T–220–240 VAC
- Eaton PW9130L2000T-XL–100–120 VAC

¹Single-phase; 50/60 Hz

²Defined as the input-to-output ratio of the UPS.

³UPS units that only connect to a serial communication port are not suitable.

⁴Command-line control is necessary for the UPS software to execute a script in the printer software when shutting down.

Communication Lines

Local Area Network

A LAN communication cable is required if server/client workstations are connected to a local network, as shown in the following diagram.

Figure 4 Network installation

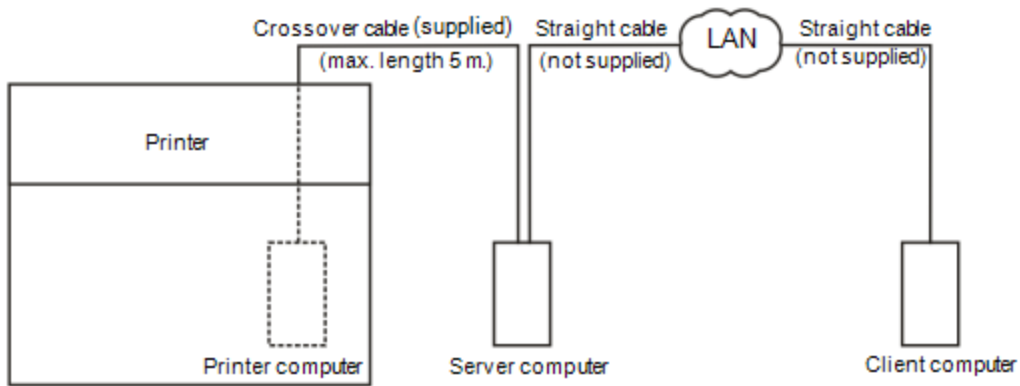

The connection to the local network should be established *prior to* printer installation.

Telephone

A telephone near the printer is recommended for general communication and service calls.

Environmental Conditions

Temperature and Humidity

The temperature and relative humidity around the printer must be maintained within certain limits. Peak conditions occur when the printer and the server workstation draw maximum electrical power, resulting in the heat dissipation listed in the table below.

Table 5 Heat dissipation (peak conditions)

	Heat Dissipation
Printer	1500 W (5140 BTU/hr)
Server workstation	450 W (1530 BTU/hr)
Total	1950 W (6670 BTU/hr)

The room temperature and relative humidity should not exceed the limits listed in the table below.

Table 6 Room temperature and relative humidity specifications

	Range
Temperature	18°C to 25°C (64.5°F to 77°F)
Relative humidity	30%–70% non-condensing

Air Quality

To ensure optimal air quality around the printer, a connection to an external ventilation duct is recommended (see "Accessories and Utilities" on the next page). Otherwise, the room ventilation system should change the air at least four times every hour.

Noise Level

The noise level around the printer is typically less than 65 dB during printing.

Accessories and Utilities

Start-Up Kit

The printer is supplied with a start-up kit, which includes tools and accessories. These tools and accessories should be available during printer installation and operation.

Exhaust Adapter

An exhaust adapter is supplied with the printer. When attached to the back of the printer and connected to an external ventilation fan with a duct, air expelled from the printer is discharged directly outdoors, as shown in the figure below.

Duct Diameter	Required Suction at the Exhaust Adapter	
	Minimum	Maximum
4 in (100 mm)	106 cfm (3 m ³ /min)	134 cfm (3.8 m ³ /min)

Figure 5 Printer exhaust system

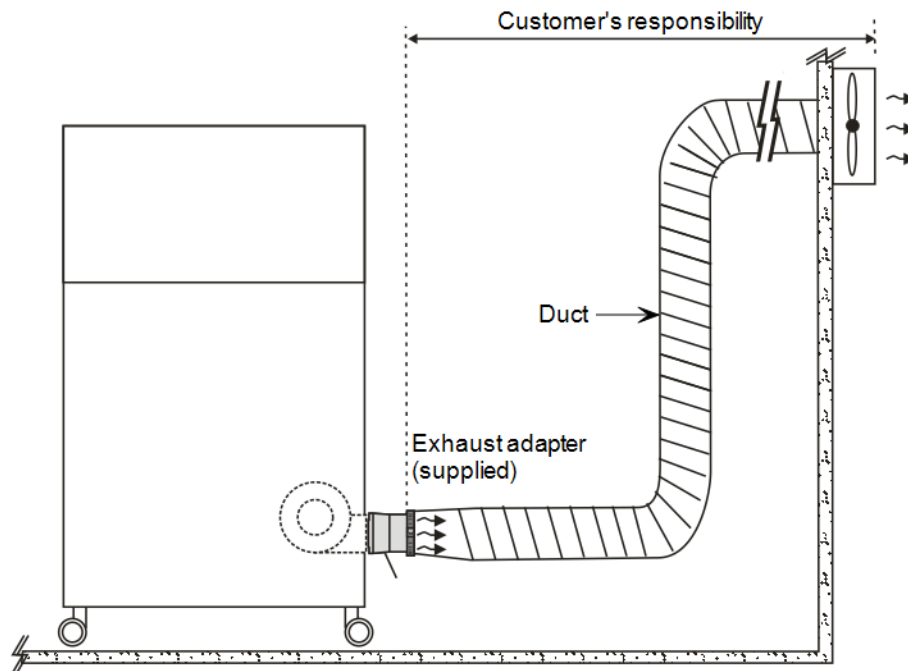

Eyewash Station

It is recommended to install an eyewash station near the printer, for emergency use.

Compressed Air

Compressed air is useful for routine cleaning and maintenance activities. If a compressed air line is available at the site, it is recommended (but not required) that an outlet be installed near the printer.

**Note:**

If the compressed air line does not include an air-dryer unit, a water/oil trap must be installed on the air gun used for cleaning the printer. The recommended air pressure is 5-7 bar (70-90 PSI).

Fire Safety Equipment

A gas-based fire extinguisher is recommended in case of fire in or near the system. Some other fire extinguishers are also acceptable, but liquid fire extinguishers should not be used. (Contact local fire authorities for specific recommendations.)

Materials Handling and Storage

Printing Materials

Printing materials should be stored indoors, in a dry area with adequate ventilation. The following table lists general requirements for transport, storage, inventory control, and disposal.

Table 7 Requirements for hazardous materials

Topic	Requirement
Storage	15°C to 27°C (59°F to 81°F)
Inventory control method	First In First Out (FIFO)
Disposal	In compliance with local regulations

These specifications are applicable for most printing materials. Requirements for handling and storing specific materials appear in the Material Safety Datasheet (MSDS) included with each material.



Note:

- Non-compliance with these recommendations might result in reduced shelf life.
- Disposal of all liquid and solid waste, cleaning cloths, gloves, and empty material containers must be done in accordance with local laws and regulations.

Cleaning Solvent

One liter of isopropanol (IPA) or ethanol (ethyl alcohol) should be available at all times for cleaning purposes.

The customer is responsible for ensuring that the material storage area complies with local regulations.

Site Preparation Checklist

A checklist is provided by your Stratasys representative listing all of the tasks described in this document.

Fill in the information requested in the checklist, and submit it to your Stratasys representative. An installation date will be scheduled after the checklist has been approved by Stratasys.



www.stratasys.com

stratasys[®]

THE 3D PRINTING SOLUTIONS COMPANY

ISO 9001:2008 Certified