

1 2 3 4 5 6 7 8

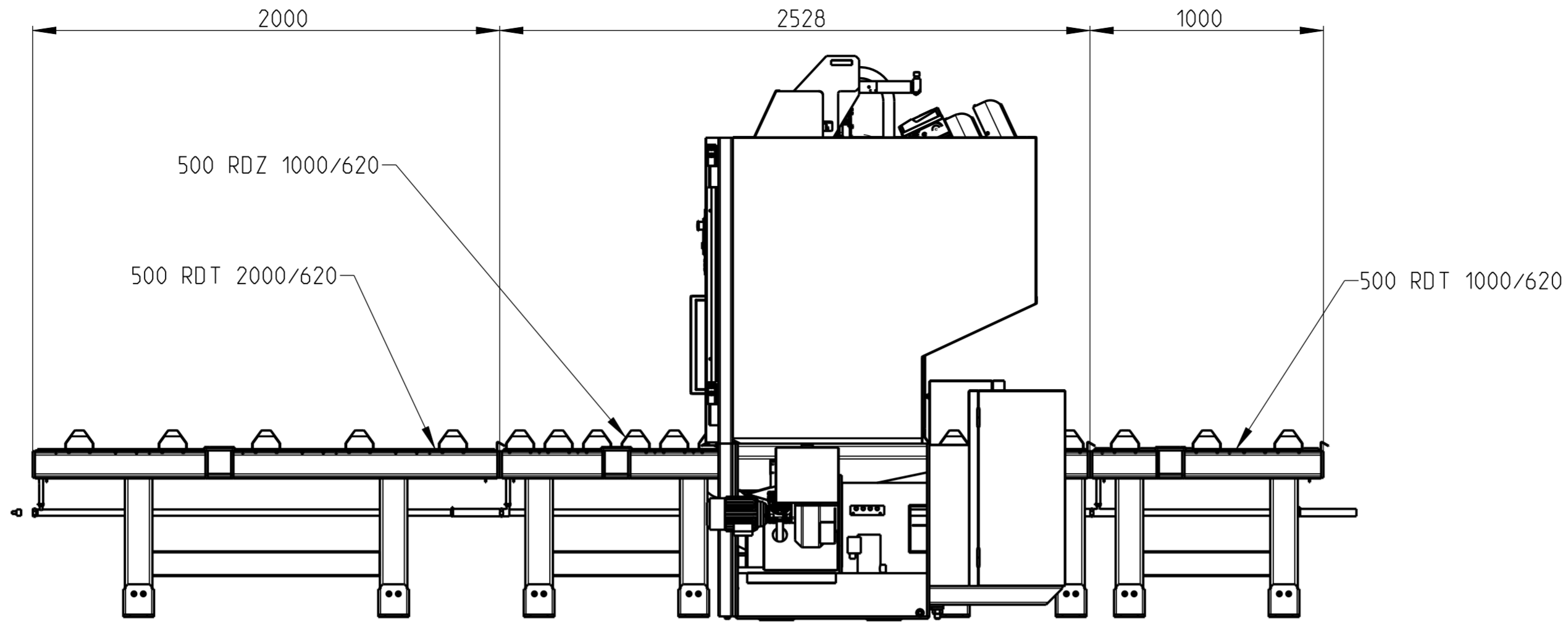

CZ: ROVINA REZU PILOVÉHO PÁSU PILY.
EN: CUTTING PLANE BAND SAW SAWS.

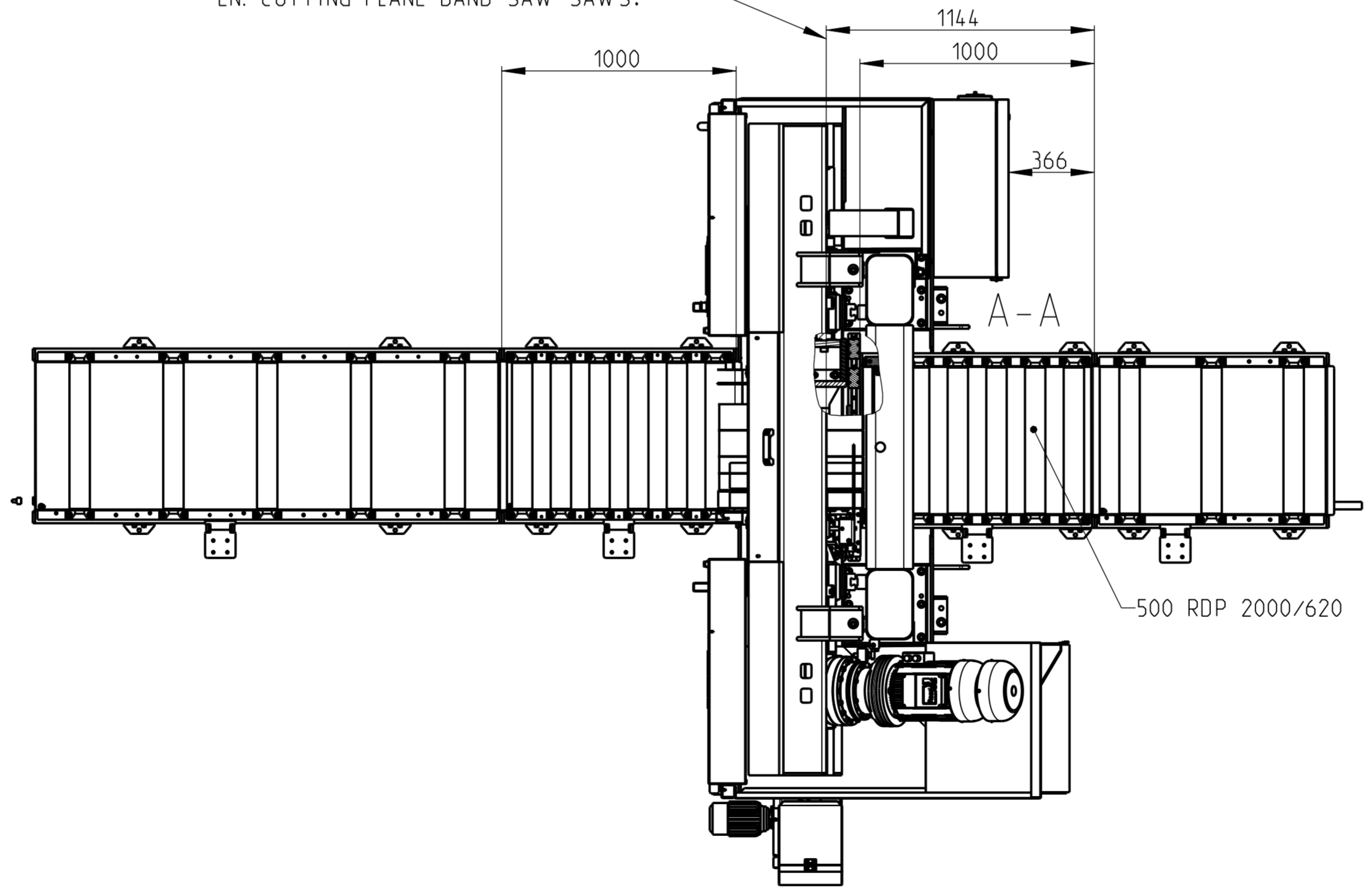

		d)		PROMÍTÁNÍ	Materiál	
		c)			Polohovár	
		b)			Celk. hmotnost	95610651079.569 kg
		a)				
		Zmena	Datum	Index	Podpis	
Meritko	Poznámka	Autor	GACH	Schválil		
1:20		Technolog				
TOLEROVÁNÍ ISO 8015		Datum vydání	23.06.2016			
ISO 2768 - mK						
Typ	500 F HERKULES- POLOAUTOMAT					
					Název	00-510-G-HERKULES-X_VSE
					Name	
					Cis. výkresu	???
						List 1/1

1 2 3 4 5 6 7 8