

## Recooler COOL

GB

Operating instructions for installation, operation and maintenance

**COILTECH**

## Description – Safety regulations and warnings

### General

The cooler is used for cooling of water or other liquids, with air. The cooling fans are separated from one another by partition walls. This permits progressive regulation of the output, as each fan can be connected or disconnected successively as the cooling requirements change.

### Marking

The rating plate is located on the connection side of the cooler and contains information about:

- Manufacturer.
- Maximum working pressure.
- Test pressure.
- Motor data.
- Order number.
- Year of manufacture.
- Dry weight.
- Internal liquid volume.

### Quality system

Fläkt Woods is certified in accordance with quality assurance system ISO 9001 and environmental management system ISO 14001.

### Handling and maintenance

Read the operating instructions carefully before using the product.

The cooler must be installed so that it is not accessible to the public. All work on the cooler must be performed by qualified personnel with knowledge of the product and the applicable safety regulations.

The top of the coolers is not designed to carry a person's weight.

### Lifting

Details of the coolers dry weight are stated on the rating plate, which is located on the connection side of the cooler.

Coolers with a length shorter than 6.0 metres can be lifted into place with help of a truck if long forks are used; see Figure 1a. Alternatively a crane can be used for lifting the cooler by the lifting eyes as shown in Figure 1b.

Before lifting the cooler:

- Check that the lifting eyes are thoroughly tightened and undamaged.
- Check that the correct lifting equipment is used and that the size of the hooks is suitable for the lifting eyes.

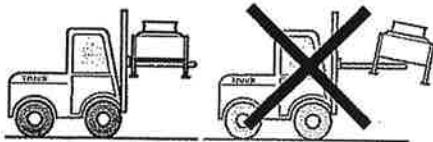

Figure 1a. Lifting with a truck.

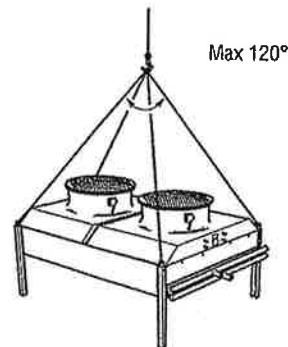

Figure 1b. Lifting by crane. The 300 and 400 series are lifted at the marked points.

### Assembly

The cooler may be securely anchored to a foundation intended for the cooler. The foundation must be sufficiently stable to bear the dry weight of the cooler, plus the weight of the liquid with which the cooler is filled.

### Operating pressure

The cooler may only be used in a system that is safe at the maximum working pressure MWP (MPa) and the maximum working temperature MWT (°C) stated on the rating plate of the cooler.

### Connections

The cooler pipe connections may not be loaded with the connected pipe systems own weight. They may not be subjected to the expansion forces of the pipe system. The connections have to be protected from impacts, external stress and strain.

**NOTE!** Loading and impacts can cause damage to the coolers' pipe

### Protection against cracking due to frost

The cooler heat exchanger cannot be drained completely, and if the risk of freezing is present, you should make sure that the heat exchanger is filled with an appropriate frost protection agent.

Details of the liquid capacity of the cooler are provided on the rating plate, which is located on the connection side of the cooler.

### Cleaning

Use only environmentally friendly cleaning agents, which do not damage the cooler.

### High temperatures

When the cooler is operating, constituent parts such as the collector pipe and the casing may be hot. The air that is blown out may also be hot.

### Explosive environment

The cooler is not designed for use in an explosive environment.

**Transport**

Check that no damage has occurred during transport or unloading. It is particularly important to check the fin surface, lifting eyes, collector pipes and the curves in the tubes on the rear side of the cooler.

Any transport damage must be reported immediately to the transporter and Fläkt Woods. The consignment note must also be marked accordingly.

**Installation**

During transport the legs of the cooler are retracted into their transport position. Extend the legs to their correct height before final positioning (not applicable to the 450 series).

Remove the transport protection under the coil after positioning the cooler on its foundations.

NOTE! Observe the recommended distance shown in Figure 2 and Table 1 to ensure an adequate air supply. Drawings relating to the positioning of the footplates and the pipe connections can be obtained on request. For other dimensions, see the dimensional drawing for the size of the cooler concerned.

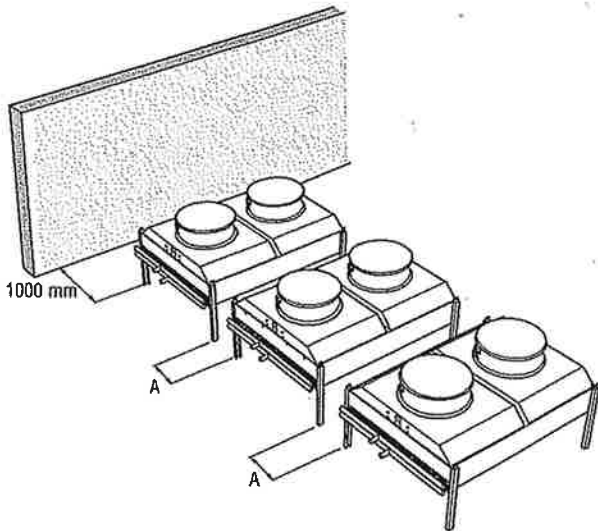

Figure 2. Positioning

Table 1

Positioning. Distance A in mm between two or more coolers.

**COOL 150**

Size aaa	A mm
151, 152 153, 154	200 600
155, 156, 157 158, 159	900 900
160, 161 162, 163 164, 165	1400 1400 1800

**COOL 250**

Size aaa	A mm
251, 252 253, 254	800 1000
255, 256 257, 258	1400 1800

**COOL 350**

Size aaa	A mm
351, 352, 353, 354 355, 356, 357, 358 359, 360, 361, 362	400 1200 1400
363, 364, 365, 366 367, 368, 369, 370 371, 372, 373, 374	1400 1400 1600
377, 378, 379, 380 381, 382, 383, 384 385, 386, 387, 388	1600 1600 1800

**COOL 450**

Size aaa	A mm
451, 452, 454 453, 455, 456	1600 1800
457, 458, 459 460, 461, 462 467, 468, 469	2000 2200 2000

# Installation

## Mechanical

The cooler must be firmly anchored in the foundations on which it is positioned. The supporting feet are provided with holes for this purpose.

Pipe connection DN32 to DN50 is provided with an external pipe thread. Pipe connection DN80 to DN100 is supplied for welded connection.

A flange connection is also available.

## Venting/Draining

The coolers collector pipes are provided with a venting and a draining nipple. The system must be thoroughly vented to ensure its effective function. If the heat exchanger cannot be drained completely, steps must be taken to prevent cracking due to frost.

## Sprinkler device

A sprinkler device is available as an accessory and is supplied separately from the cooler. Its assembly is described in separate assembly instructions.

When the risk of freezing is present and the cooler is equipped with a sprinkler device, the latter must be drained by opening the drain plugs.

## Electrical

Every fan motor is connected to a lockable safety cut-out. The safety cut-out may not be used for starting and stopping. Starting/stopping must be performed by using other external equipment.

The system must include an emergency cut-out which overrides all other equipment. The motor must be preceded by a motor protector, with a maximum setting equivalent to the motors I max value (Table 2), which is the motors maximum allowed current. This is necessary because certain motors can be overloaded before the airflow reaches the design temperature. The motor is not subject to the risk of damage because it is cooled by the cold air.

The electrical supply cable L1, L2, L3 and the earthing cable are connected as shown in the wiring diagrams in Figure 9 to Figure 12. When the motor is electrically connected, check that the impeller wheel rotates in the direction of the rotation arrow. The indication is positioned on the outside of the fan ring.

## Dismantling

When dismantling the cooler from a system, it is important that the cooler is drained of liquid. See also the section Venting/Draining above.

**NOTE!** Environmentally hazardous liquids must be collected in vessels and sent for disposal or recycling. The cooler may not be lifted before it has been drained of liquid.

## Maintenance and service

### General

The cooler should be inspected regularly to avoid operating breakdowns.

The following points should be checked:

1. Noise or vibrations can be caused by a damaged motor bearing or a damaged impeller wheel.
2. Fixing elements – Check if any load-bearing screwed connections are defective.
3. Electrical installation – Check if any damage is visible.
4. Finned body – Check if it is dirty or damaged.

### Cleaning the coil

Preferably the finned heat exchanger should be cleaned by high-pressure washing.

The contact protection in the fan outlet should be removed to permit spraying against the direction of the air in the finned heat exchanger. See Figure 3, or remove the end wall on the 450 series; see Figure 4.

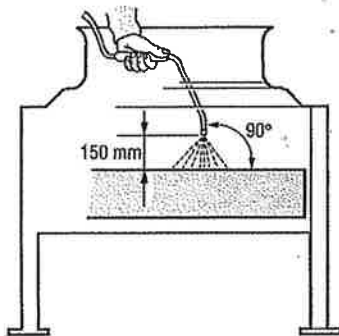

Figure 3. Cleaning with water, COOL 150, 250 and 350.

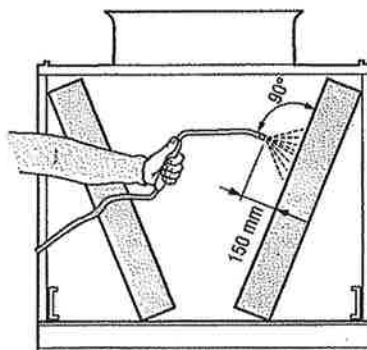

Figure 4. Cleaning with water, COOL 450.

First spray the entire coil with an environmentally friendly solvent at low pressure. Then carry out high-pressure washing with water after 10-12 minutes. It is important to hold the nozzle perpendicular to the fin surface but not closer than 150 mm.

The finned body may not contain any residues of the solvent after washing, since such residues will act as a trap for new dust.

Any deformed fins can be straightened with a fin comb (QLAZ-20), which can be ordered from Fläkt Woods.

### Fan motor

The fan motors are lubricated for life. Grease has limited resistance to ageing, and it is recommended to replace it at regular intervals to ensure the best lubrication.

See directions in the motor instructions.

A special heat-resistant grease is used in certain installations, where the ambient temperature for the fan motor is high.

Motors and impeller wheels are accessible for inspection by removing the contact protection.

### Repair

Components and materials recommended by Fläkt Woods must be used in order for any warranties to be valid.

### Spare parts

In installations with very high requirements for availability, we recommend that a motor, a safety cut-out and an impeller wheel are kept as spare parts.

If electric motors are kept in stock, they must be checked after a certain period of time and certain parts must be replaced in line with the recommendations in the motor instructions.

All motors must be stored indoors in a dry and dust-free environment.

For other installations, motors and impeller wheels are available from Fläkt Woods. In conjunction with the installation of a spare motor, the lowest drain plug in the motor must be opened. The plug is normally located behind the motor's cooling fan.

## Maintenance and service

### Replacement of impeller wheel and motor

- 1 Disconnect the power supply to the motor in the control cabinet. Lock the safety cut-out in the OFF position.
- 2 Release the fixing screws for the contact protection and remove these.

- 3 **Figure 5a. COOL 100 series.**  
Release the screw and washer in the fan hub and pull off the impeller wheel. It may be necessary to use a puller.

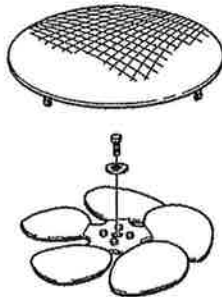

Figure 5a. Impeller wheel COOL 100 series

- 4 **Figure 5b. COOL 250, 300 and 450 series.**  
Release the screw on the cover. The two socket head cap screws that are now visible in the fan hub are released and placed in the holes provided alongside. Then tighten the screws a little one at a time until the impeller wheel is released from the shrink-fit taper.

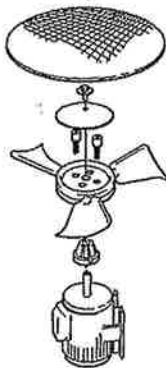

Figure 5b. Impeller wheel COOL 250-, 300- and 450-series

- 4 Fit a lifting eye at the end of the motor shaft.  
150 series M8.  
250 series M10 (6-pole M12).  
350 and 450 series M16 (12-pole and 16-pole M12).
- 5 Disconnect the electric cable from the motor junction box.
- 6 Secure the motor to the lifting eye on the shaft journal, or alternatively in a lifting device. If a lifting beam is used to lift out the motor, take care to prevent damage to the fan ring.

- 7 **Figure 6a. COOL 150 and 250 series.**  
Release the screws which secure the motor to the motor shelf. Lift out the motor.

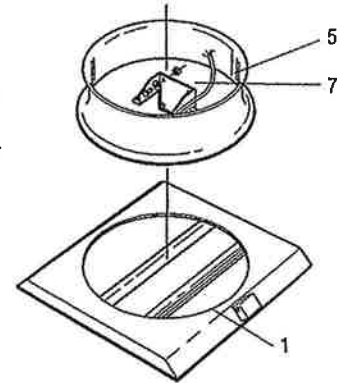

Figure 6a. Motor suspension COOL 150 and 250 series

- 8 **Figure 6b. COOL 350 and 450 series.**  
Release the screws which secure the rubber dampers and lift out the motor with the inner motor bracket still attached.

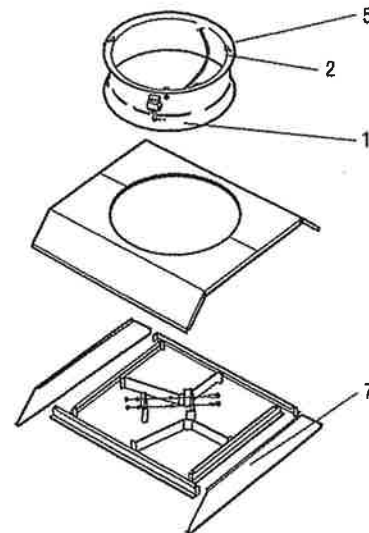

Figure 6b. Motor suspension COOL 350- and 450-series

- 8 For installation of fan and/or motor. Perform these points in reverse order. Use a torque wrench when tightening load-bearing screwed connections.
- 9 When installing the impeller wheel on the motor shaft, rust prevention should be put on the shaft and screw.
- 10 Before starting, check that the impeller wheel is centralized on the fan ring and that the rotation direction corresponds to the direction of the rotation arrow.

## Technical specifications

### General

Max. allowed operating pressure: 1,6 MPa at 150 °C  
Test pressure: 2,1 MPa

### Weight and volume

The coolers dry weight and internal liquid volume are stated on the coolers product plate.

### Coil

The coolers coil is constructed from tubes which are mechanically expanded to the fins.

In order to prevent that dust and fibres become attached to the finned body, the fins are manufactured as whole plates without slots.

The coil collector pipe, which distributes the liquid in the pipe loops of the coil, is provided with an airing and draining nipple with a G1/2" thread.

Pipe connection DN32 to DN50 is provided with an external pipe thread. Pipe connection DN80 to DN100 is supplied for welded connection.

A flange connection is also available.

### Motor / Fan

The fan motor is a squirrel-caged three-phase totally enclosed motor with foot mounting, manufactured from pressure die-cast aluminium. The directly driven axial fan is manufactured from aluminium sheet with an epoxy painted steel hub. The impeller wheel is statically balanced in accordance with ISO 1940, Class G6.3. The fan outlet is provided with a contact protection which can be dismantled for inspection of the fan and motor or for cleaning the coil body.

### Enclosure classes

The fan motor has enclosure class IP55 with open drain holes at the motors' lowest drain point.

The safety cut-out has enclosure class IP54.

Table 2

Motor data also stated on the cooler rating plate.

### COOL 150

Fan speed r/min	Code bb	Rated output, kW	Rated current, A	I <sub>max</sub> A	Weight kg
325	16	0,06	0,6	0,75	14
440	12	0,15	0,8	0,9	14
710	08	0,55	1,7	1,9	14
930	06	1,2	3,8	4,3	14

### COOL 250

Fan speed r/min	Code bb	Rated output, kW	Rated current, A	I <sub>max</sub> A	Weight kg
320	16	0,2	1,5	1,5	24
460	12	0,55	3,0	3,0	24
660	08	2,2	6,8	7,5	24
960	06	4,8	11,0	12,1	46

### COOL 350 och 450

Fan speed r/min	Code bb	Rated output, kW	Rated current, A	I <sub>max</sub> A	Weight kg
325	16	0,7	4,6	5,0	58
445	12	1,5	7,0	7,3	55
575	10	3,4	11,0	12,1	97
710	08	5,5	13,0	14,3	85
965	06	13,0	27,0	29,7	102
475/715	20	2,1/6,7	8,0/17	8,8/18,7	97

## Connection diagram/Product specification

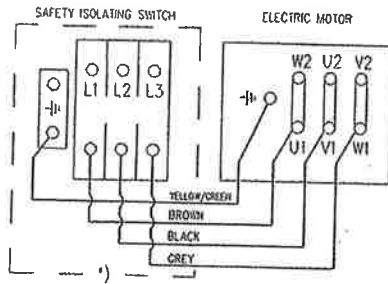

Figure 7. 1-speed, D-connection

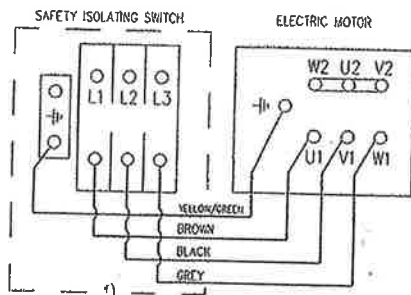

Figure 8. 1-speed, Y-connection

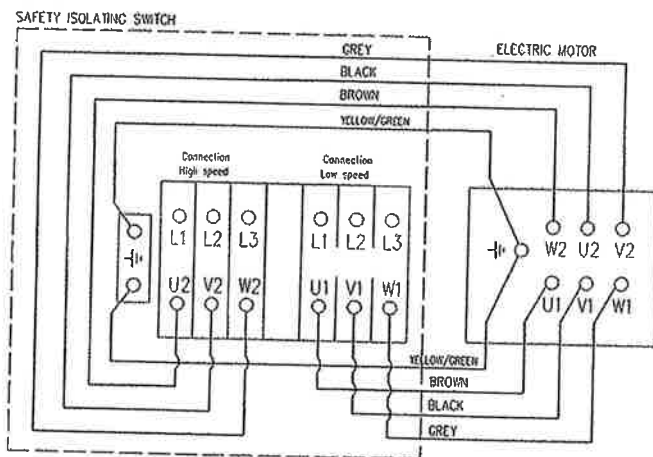

Figure 9. 2-speed, separate stator windings

Recooler

COOL-aaa-bb-cc-ddd-ee

Size (aaa)

151-165, 251-258, 351-388,  
451-469

Number of poles/speed (bb)

see number of poles and speed in  
Table 2 under technical specifications

Number of liquid paths (cc)

02, 04, 06, 08, 10, 12

Connection size (ddd)

Connection Code ddd	Connection dimension	Maximum fluid flow l/s
32	1*32	2,8
50	1*50	7
80	1*80	14,4
100	1*100	23,5
82	2*80	28,5
102	2*100	47

Material and construction number (ee)

11

**COILTECH**

Coiltech AB: SE-614 81 Söderköping  
Phone +46 121-19100  
Fax +46 121-10101  
www.coiltech.com

Coiltech, Afrikalaan 303, BE-8000 Gent, Belgium  
Phone +32 9 218 71 30  
Fax +32 9 218 71 39



Head Office:  
33050 POCENIA (UD) | Via Giulio Locatelli, 22  
Phone +39 0432.772.001  
Fax +39 0432.779.594  
www.ecogroup.com  
info@ecogroup.com





Coiltech AB | 614 81 Söderköping | Tel 0121 191 00 | Fax 0121 101 01 | www.coiltech.se  
Org nr: 556668-0657 | Styrelsens säte: Söderköping



## Declaration of Conformity

(in accordance with MD 98/37/EG, LVD 2006/95/EG, EMCD 2004/108/EG)

---

**Manufacturer:** Coiltech AB  
Industrigatan 2  
SE-614 81 SÖDERKÖPING  
Tel +46 121 19100  
Fax +46 121 10101

**Products:** Cooling medium coolers/Condensers, type COOL 451-462 och 467-469

We hereby declare that the above-mentioned coolers satisfy the fundamental health and safety requirements of the Machinery Directive in respect of their design and construction in Directive MD 98/37/EC concerning the mutual harmonisation of the Member States' legislation governing machines.

We also declare that we satisfy the requirements in accordance with the Low Voltage Directive, LVD 2006/95/EG and the EMC Directive, EMCD 2004/108EG.

Söderköping 2008-08-22

Coiltech AB  
Technical Department

*Simon Hulterstam*  
Technical Manager



Head Office:  
IT-33050 POCENIA (UD) | Via Giulio Locatelli, 22 | Tel +39 0432 772 001 | Fax +39 0432 779 594 | e-mail: info@ecogroup.com | www.ecogroup.com

R1071138-0002 edition A