

VIBRATION SCREEN COMPACT - DOUBLE-DECK

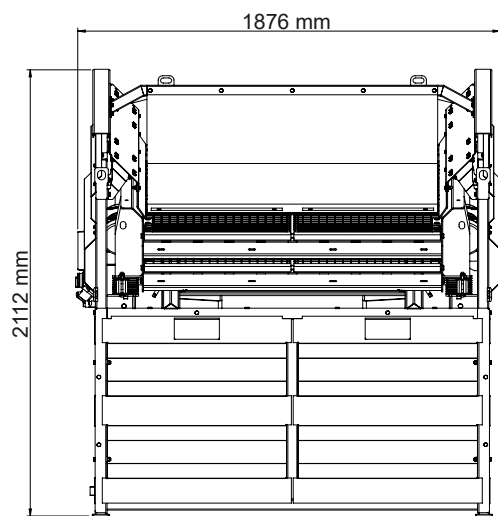

The vibration screen ASCO® VS COMPACT offers a robust and powerful basis for a wide range of screening tasks. With two vibration motors, it is particularly practical for recycling companies and businesses in the construction, agricultural and gardening sectors where many different materials have to be processed in tight time frames.

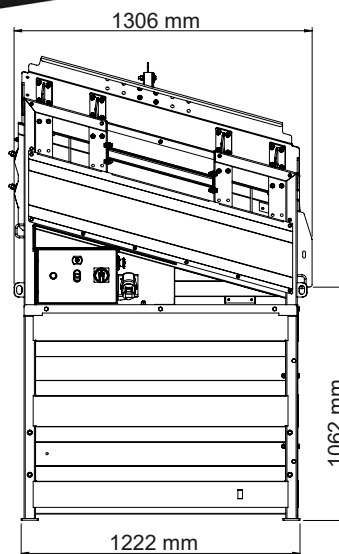
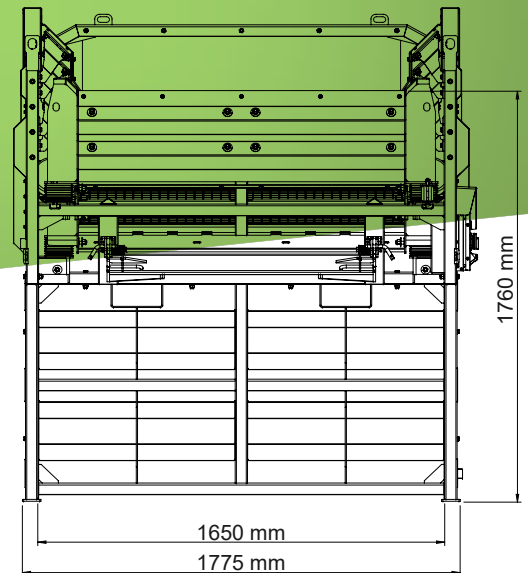

△ TECHNICAL DATA

- △ System performance: up to 18 m³/h
- △ Maximum bucket width: 1,65 m
- △ Screen area: 3 m²
- △ Drive power: 400 V / 2 x 0,35 kW
- △ Weight: 621 kg
- △ Width: 1,88 m
- △ Length: 1,31 m
- △ Height: 2,11 m
- △ Loading height: 1,76 m
- △ Recommended amperage for fuses: 6 A

△ ADDITIONAL OPTIONS

△ Bar-Sizer



Weight: 130 kg

Additional separation option for coarse material with improved screening results that leads to a fine fraction.

△ Hopper



Weight: 16 kg
Increases effectiveness of the material supply.

△ Support feet



Weight (4 pieces): 64 kg
Quickly adjust the screening angle and level out an uneven terrain when setting up the machine.

△ Separation plate



Weight: 134 kg
For an additional separation of a third fraction.

