

MAIN FEATURES

Highest quality and reliability.	Wide range of standard and optional equipment.
ComAp IntelliLite AMF 25 controller.	Engine heater – ready to load just after start.
Ready to control MAINS – GENERATOR transfer switch.	Drip tray,
Configured for both manual and automatic mode (MRS + AMF).	Anticorrosion coating: frame - Zr, canopy – Zr, Al-Zn.
Wide range of remote communications options.	Brushless alternator.
Schneider NS type GCB.	

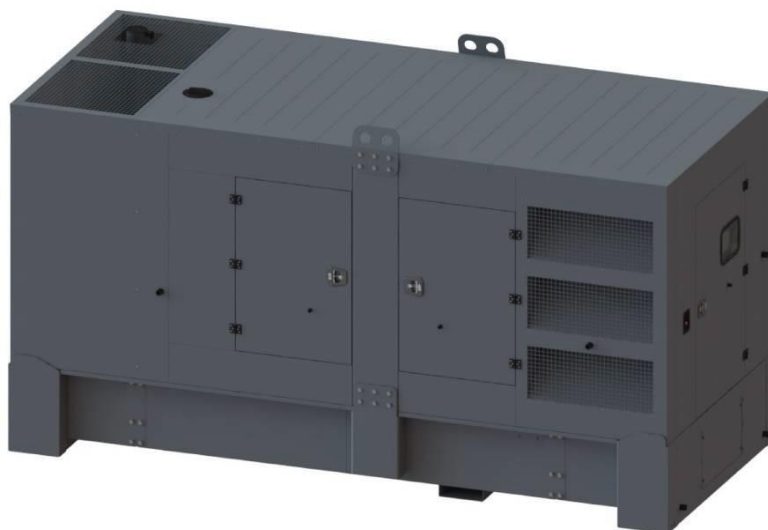

The presented image is for illustration purpose only.

GENERAL DATA

Code	DPX-17953
Standby power E.S.P. [kVA] / [kW]	550,0 / 440,0
Prime power P.R.P. [kVA] / [kW]	500,0 / 400,0
Prime current P.R.P [A]	722,0
Frequency [Hz]	50
Voltage [V]	400
Exhaust emission	fuel optimized
Fuel type	Diesel (EN 590)
Fuel consumption - 50% load [l/h]	48,8
- 75% load [l/h]	71,7
- 100% load [l/h]	99,5
- 110% load [l/h]	111,5
Standard fuel tank capacity [l]	990
Autonomy with 100% load [h]	9,9
Engine control voltage [V]	24
Weight without fuel [kg]	4580
Dimensions L x W x H [mm]	4560 x 1961 x 2521
Guaranteed noise power Lwa [dBA]	103
Acoustic pressure Lpa (7m) [dBA]	71,7 ± 1,9

Nominal power P.R.P.:

Prime power available in variable load application in accordance with ISO 8528, 10% overload capacity is available for a period of 1 hour within a 12-hour period of operation. Average power consumption should not exceed 70% PRP for each 24-hour period of operation.

Stand-by power E.S.P.:

Emergency standby power rating is applicable for supplying emergency power for the duration of a utility power interruption. No overload allowed, limited to 200h of operation per year. Max mean load factor of 70% of rated power over 24-hour period of operation.

Remark:

Ratings represent the genset performance capabilities to standard conditions specified in ISO 8528-1

Norms and directives:

- Machinery directive 2006/42/EC
- Low voltage directive 2014/35/EC
- EC directive 2014/30/EC
- Noise directive 2000/14/EC
- Emission directive 97/68/EC
- ISO 8528-1:2018, ISO 8528-5:2018
- ISO 8528-13:2016
- EN 60204-1

STANDARD CONTROLLER

Controller type: ComAp IntelliLite AMF 25

Easy to operate, intuitive graphical interface

Real time clock with battery supply

Stan-by and Prime power applications, AMF function available

Flexible event based history with up to 350 events

3 Phase generator current measurement

Generator and Mains phase voltage measurement

Active/reactive power measurement

Active and reactive energy counter

Running hours counter, multipurpose flexible timers

Battery charging alternator circuit connection

Comprehensive gen-set protections

Wide range of communication capabilities including :

- CAN and USB on board
- Internet access using Ethernet, GPRS or 4G module
- Support for Modbus and SNMP protocols

Cloud-based monitoring and control via WebSupervisor

Active SMS or e-mails (module required)

Geofencing and tracking via WebSupervisor

Operating temperature -20 + 70°C

IP65 operator interface protection

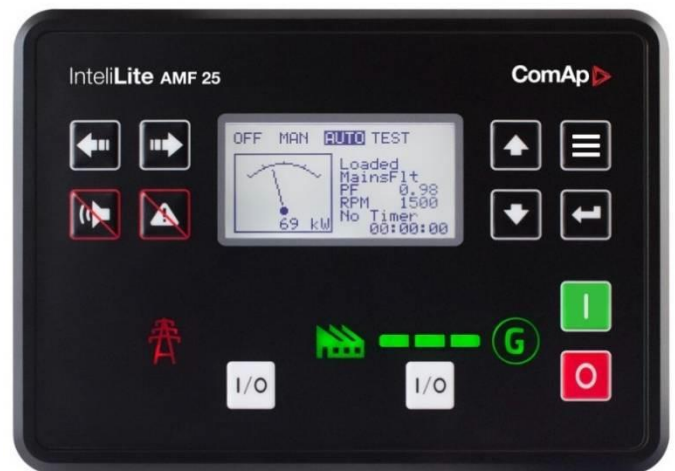

ENGINE

Brand	Scania
Type	DC13 072A 02-14
Made in	Sweden
Engine power [kW]	428,0
Emission standard*	fuel optimized
Rotation per minute [rpm]	1500
Engine governor	electronic
Governor class**	G3
Displacement [l]	12,7
No of cylinder	6
Fuel system	unit injectors, PDE
Electrical system [V]	24
Cooling system capacity [l]	38,0
Oil pan capacity [l]	36,0
Fuel type	Diesel (EN 590)

ALTERNATOR

Nominal Voltage [V]	400
Nominal power factor (cos phi)	0,8
Ambient temperature, altitude	40 °C, 1000m a.m.s.l
Nominal Power [kVA]	500,0
IP protection	IP 23
No of bearing	single bearing
Coupling	direct
Technology	brushless
Short circuit maintaining capacity	270% 10s
Efficiency [%]	93,9
Insulation class	H
Total harmonic content THD [%]	1,5
Reactance Xd'' [%]	15,2
Voltage regulator type	DVR, digital
Voltage measurement	3 phases
Voltage accuracy [%]	+/- 0,25
AVR supply system	auxiliary winding
AVR supply optional	PMG
Made in	EU

* According directive 97/68/EC non road mobile machinery engine emission.

** According ISO 8528-5:2018

STANDARD EQUIPMENT

OPTIONAL EQUIPMENT

Scania DC13 072A 02-14 engine	✓	Battery disconnection switch	<input type="checkbox"/>
Electronic engine speed governor	✓	GCB 4P Schneider NS Micrologic 2.0	<input type="checkbox"/>
Oil low pressure switch	✓	Power Lock type power output	<input type="checkbox"/>
Oil pressure sensor	✓	Power socket box	<input type="checkbox"/>
Engine high temperature switch	✓	Transfer switch controlled by generator controller	<input type="checkbox"/>
Engine high temperature sensor	✓	Transfer switch with ATS controller	<input type="checkbox"/>
Engine preheating with thermostat	✓	GPRS communication card	<input type="checkbox"/>
Engine oil Titan Cargo 15W40	✓	Ethernet card	<input type="checkbox"/>
Fuel filter with water separator	✓	RS 485, RS 232 card	<input type="checkbox"/>
Coolant Fuchs Maintain Fricofin LL-35	✓	Remote display	<input type="checkbox"/>
Coolant inlet outside of the canopy	✓	Drip space level sensor	<input type="checkbox"/>
Starting batteries 2x180Ah	✓	External fuel tank 1 000 – 10 000 l	<input type="checkbox"/>
Battery charger	✓	3-way valve for external fuel tank connection	<input type="checkbox"/>
GCB Schneider NS800 3P + Micrologic 2.0	✓	Fuel tank filling pump and shut-off valve	<input type="checkbox"/>
GCB shunt release coil	✓	Non-standard canopy color (RAL palette)	<input type="checkbox"/>
Bar connection	✓	Oil draining hand pump	<input type="checkbox"/>
Controller ComAp InteliLite AMF 25	✓		
Acoustic alarm	✓		
Emergency stop button	✓		
Silenced canopy made with Al.-Zn.	✓		
Standard color RAL 7024	✓		
Fuel tank installed in drip tray	✓		
Welded frame with fuel tank	✓		
Fuel inlet inside, protected by canopy locked doors	✓		
Fuel level measurement	✓		
Exhaust compensator and silencer	✓		
Engine and alternator vibro isolators	✓		
Transportation brackets	✓		

INSTALLATION GUIDELINES

Power terminal	Busbar
Recommended cable for up to 30m power cable way	Flexible 2x5x240 mm ²
Recommended cable for do 30m generator heater supply	Flexible 3x2,5 mm ²

*For additional cable connection with FOGO ATS see ATS wiring diagram

Exhaust pipe min diameter (max. 7 m, 4 bends)	133 mm
Exhaust pipe min diameter (max. 15 m, 4 bends)	

MAINTENANCE GUIDELINES

Fuel filters replacement	500 h / 1 year
Oil replacement	After first 100h, then every 500 h / 1 year
Oil filters replacement	After first 100h, then every 500 h / 1 year
Coolant replacement	1000 h / 2 years
Battery replacement	2 years
Electrical installation supervising	According to local requirements, at least once per year

WARRANTY

Continuous work generators	12 months up to 1000 working hours
----------------------------	------------------------------------