

HYUNDAI WIA L5100LY

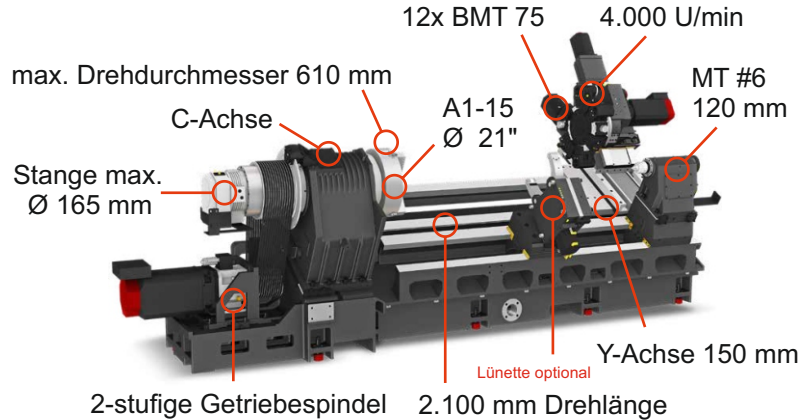

45/37 kW 2.990/2.459 Nm 1.500 U/min Fanuc i Serie



max. Drehdurchmesser 610 mm

C-Achse

Stange max.
Ø 165 mm

2-stufige Getriebespindel

12x BMT 75

4.000 U/min

A1-15
Ø 21"

MT #6
120 mm

Lünette optional

Y-Achse 150 mm

2.100 mm Drehlänge